

BDS **SUSPENSION**

Bad Ass Lift Kits

Hardcore Lifetime Warranty

No BS, It's Our Pleasure!

2014 MASTER CATALOG

A wholly owned subsidiary of **FOX**



CONTENTS

SUSPENSION SYSTEMS

Chevrolet/GMC	9-30
Dodge	31-54
Ford	55-85
Jeep	86-113
Suzuki	114
Toyota	115-118

4X4 POSI-LOK™	119
---------------------	-----

FOX COIL-OVERS	120
----------------------	-----

SHOCK ABSORBERS/STEERING STABILIZERS	121-130
--	---------

ADD-A-LEAF AND U-BOLT APPLICATION CHART	131-132
---	---------

ACCESSORIES	133-141
-------------------	---------

CLOTHING & APPAREL	142
--------------------------	-----

PROMOTIONAL PRODUCTS	143
----------------------------	-----

SPECIFICATIONS

Leaf Springs	144
Add-a-Leafs	144
Coil Springs	145
Alignment	146
Installation Time and Tire Size Guide	147-150
OE Wheel	151

BDS MISSION

The mission of BDS Suspension, a company dedicated to reliability and customer satisfaction, is to produce high quality products at affordable prices. Our warranty reflects our mission and our confidence in every product we manufacture.

- Founded in 1995
- The only "No Fine Print" Warranty in the industry
- BDS Authorized Distributors can be found across the US and around the globe
- Experienced sales and technical support to help you every step of the way
- "Never Out" philosophy - our goal is to ship every order the same day
- Most "User Friendly" catalog in the industry
- "Self-selling" packaging - 4 color, retail-friendly packaging that says quality inside!
- Most accurate, complete, and installer friendly instructions shorten installation time

WHY BDS SUSPENSION?

BDS Suspension operates with one guiding premise—to provide true value to the customer by manufacturing the highest quality product at a competitive price, distributed and serviced by the premiere jobber/installer expert! What does this mean to you? Simple, we strive to have the best installation instructions, easy to install kits, best performing suspension systems, the best warranty in the business and we're never out of inventory. If you want a lift kit and it's in this

catalog, then it is available. In addition, we have a dedicated staff to assist you with any questions that arise and pride ourselves on strong customer service. We have built a strong web site to assist with application selection as well as technical information that is available 24 hours a day. We are constantly working on new product, so please check out the web site that is updated immediately when product is available.

2014 CATALOG

BDS Suspension's 2014 catalog is designed to be the most user friendly catalog in the truck suspension aftermarket. Through research and consultation with the experts—our BDS distributors and dealers—we have created several innovative features designed to assist in the sale of BDS Suspension.

These include:

- Add-A-Leaf and U-Bolt chart for high demand applications
- Coil Spring, Leaf Spring, and Add-A-Leaf Specifications
- Installation Time Guide provides “real time” estimates on labor hours and tire and wheel size information
- Pricing Code is available for instant price quotes
- Alignment Specifications
- OE Wheel Specifications

DISCLAIMER

BDS Co. reserves the right to update products as necessary without notice, and will not be held responsible for misprints in this catalog or changes/variations made by vehicle manufacturers.

DISTRIBUTION

BDS products are not available through mail order companies. We believe it is in the best interest of the consumer to distribute our product through a network of dedicated, experienced, 4WD enthusiasts.

Our distributors have installed our products, and have the ability to answer questions before and after the purchase. Our mission is customer satisfaction. We believe we can achieve that satisfaction by limiting the distribution of BDS products to expert installers.

SHOP OWNERS

BDS Distributors are carefully selected by BDS Suspension. Our goal is to find honest, experienced, retail/ installers who are 4WD enthusiasts. We look for shops who are committed to the 4WD market with a reputation for good customer service. If you feel that we have just described you and your operation and want to be considered for a distributorship, please call 517-279-2135.



HOME OF BDS SUSPENSION

BDS Suspension is the premier division of Sport Truck USA Inc., a wholly owned subsidiary of Fox. BDS recently expanded its Coldwater, MI based offices now offering over 100,000 sq ft of warehousing and offices along with the adjacent 16,000 sq ft of R&D facility residing on 25 acres. These new spaces allow us to further expand and better serve our customers in the years to come.



BDS WARRANTY

YOUR WARRANTY IS VALID IF ...

<i>Product is Abused</i>	YES!
<i>Product is Misused</i>	YES!
<i>Used in Competition</i>	YES!
<i>Installed on Government Vehicles</i>	YES!
<i>Installed on Commercial Vehicles</i>	YES!
<i>Installed on Vehicle Other than Specified</i>	YES!
<i>Used with Larger Tires</i>	YES!
<i>Combined with Other Brands</i>	YES!
<i>Product Has Been Painted</i>	YES!
<i>Parts Have Been Removed and Reinstalled</i>	YES!
<i>You Live Outside of the U.S.A.</i>	YES!
<i>Used With Other Brand of Shocks</i>	YES!

SHOCK AND STABILIZER CYLINDER LIMITED LIFETIME WARRANTY:

BDS Suspension Co. warrants to the original retail purchaser that its shock and stabilizer cylinders are free from defects in material and workmanship for so long as they own the vehicle. Excluded from this warranty are the finish of the product and mounting bushings. Defects in material and workmanship do not include such things as dented cylinders or bent rods caused by obvious side impact, rust, worn or deformed bushings. A shock absorber is a wear item and over time will experience diminished damping resistance due to normal component wear. This is not a defect in material or workmanship and is therefore not warrantable. BDS Suspension's obligation under all warranties is limited to the repair or replacement, at BDS's option, of the defective material. Any cost of removal, installation or reinstallation, freight charges, incidental or consequential damages are expressly excluded from these warranties.

WHAT WE DON'T COVER:

Our attorney says we need to tell you, BDS' Limited Warranty doesn't cover damage to your vehicle, non-BDS products or non-BDS components. We don't cover wear and tear items (ex. tires, shocks and stabilizers), components of the vehicle's electronic stability control system, Acts of God, accidents, theft, vandalism or other intentional damage.

Neither BDS or any independent distributor are responsible for any time loss, rental costs, removal or repair costs, or any other incidental, consequential, punitive or other damages you may have or incur in connection with any BDS part purchased. Your exclusive remedy hereunder for covered parts is we will replace the part as described above.

This Limited Warranty gives you specific rights. You may also have other rights that vary from state to state. For example, some states do not allow limitations of how long an implied warranty lasts and/or do not allow the exclusion or limitation of incidental or consequential damages, so the limitations and exclusions herein may not apply to you.

All other warranties are hereby disclaimed, except to the extent prohibited by applicable law, in which case any implied warranty of merchantability, fitness for a particular purpose or other implied warranty are limited to a period of four (4) years from date of original retail purchase. For warranty service call us with invoice or other proof of purchase (517-279-2135).

© BDS, INC., 2014. All Rights Reserved.

BDS warrants to the original purchaser of its products that its products shall be free of defects in materials and workmanship for so long as the BDS product is installed on the original purchaser's vehicle. Your exclusive remedy upon BDS' inspection is: IF IT BREAKS WE WILL GIVE YOU A NEW PART.



REVOLUTIONARY HIGH CLEARANCE DESIGN

HIGH CLEARANCE CROSSMEMBERS

The main crossmembers in the new high clearance systems have been designed to maximize ground clearance while improving suspension and steering geometry over other systems on the market today. This new method of IFS design has many benefits over more traditional setups:

- Reduced camber change throughout wheel travel
- Entire system designed to put all suspension, steering and driveline angles in-phase, increasing performance and reducing wear on OE components
- Unique high clearance appearance



NO TORSION BAR DROP SYSTEM

HIGH CLEARANCE TORSION BAR APPLICATIONS INCLUDE THE BDS NO TORSION BAR DROP SYSTEM, NTBD TECHNOLOGY FOR SHORT. THIS IS A REVOLUTIONARY DESIGN OFFERING IMPROVED GROUND CLEARANCE FOR OFFROAD CAPABILITY.



INDUSTRY LEADING NO TORSION BAR DROP TECHNOLOGY

- Relocation brackets bolt solid to the factory lower control arm
- No moving parts to wear out or break
- Torsion bar crossmember stays in the factory location keeping the torsion bars hidden inside the frame rails for maximum ground clearance
- Factory torsion bar adjustment range is maintained...the torsion bars don't have to be "cranked" up to achieve the correct lift height

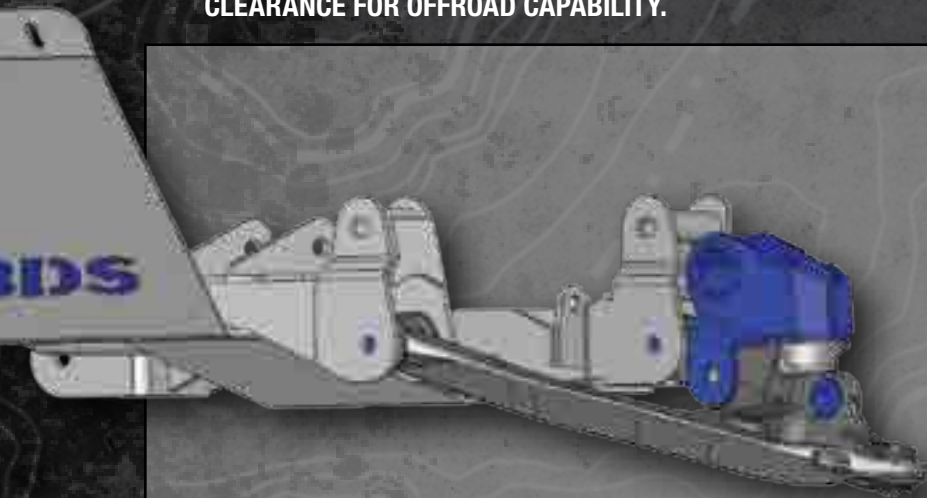

FOX COILOVER SHOCKS

BDS SUSPENSION NOW OFFERS PERFORMANCE SERIES SYSTEMS FOR POPULAR IFS APPLICATIONS UTILIZING FOX RACING'S FACTORY SERIES 2.5 REMOTE COIL-OVERS. THESE NEW COIL-OVERS COME TUNED TO OUTPERFORM ON DIRT, SAND, OR ANY OTHER TERRAIN YOU THROW AT THEM. THEY UTILIZE COIL SPRINGS PRELOADED TO GIVE YOU THE PROPER RIDE HEIGHT RIGHT OUT OF THE BOX AND ARE FULLY ADJUSTABLE. REMOTE RESERVOIR BRACKETS ARE INCLUDED MAKING INSTALLATION A BREEZE. ORDER THEM WITH YOUR BDS LIFT KIT OR UPGRADE YOUR CURRENT STRUT MOUNTED LIFT KIT.

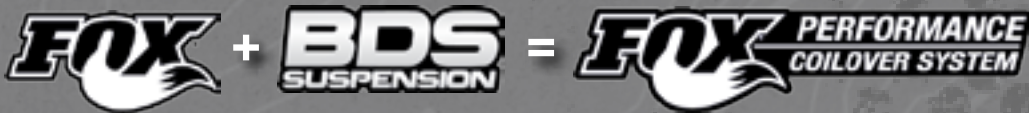

THE FOX 2.5 COIL OVERS PROVIDE THE ULTIMATE UPGRADE TO THE ALREADY HIGH-PERFORMANCE BDS

- Smooth bore, clear coated and zinc plated alloy bodies.
- 6061-T6 billet aluminum, black anodized mounting components
- 7/8" hard chrome plated, heat treated alloy steel shaft
- Race-developed, high flow piston design
- Application specific valving for maximum performance on and off road
- Oil is specially formulated for high performance at varying temperature ranges and sealed with a redundant main/wiper/scraper sealing pack
- External reservoir separated shock oil from the high-pressure nitrogen charge
- Coil preload is set for proper ride height right out of the box



The new coil-over kits can be purchased separately for vehicles already equipped with a BDS system or as a complete lift system.

CATALOG...HOW TO

1 1994-1999 DODGE 2500 4WD TRUCK - GAS & DIESEL

Lift & Method	Qty	Part#	Description	Optional Accessories	Notes	
2 4.5" Front / 4.5" Rear 3 Standard Kit 4 Front Coils & Brackets 5 Rear Blocks & Add-A-Leafs w/o top ovid Kit #211H with top ovid Kit #212H 64DK2151	1	032503	Front Coil Springs 6	122303	Dual Shock Bracket Kit 9a	1
	1	012503	Front Box Kit	55650	Dual Shock Shock (2 req'd) or	2 10
	1	012456	2" Block & Add-A-Leaf Kit w/o top mounted overload or	95650	Dual Gas Shock (2 req'd)	3
	1	012457	2" Block & Add-A-Leaf Kit with top mounted overload 7	122304	Lower Link Skid Plate Kit	
	1	55417	Single Steering Stabilizer	PSL400	4x4 Posi-Lok™ (page 119)	
	2	55750	Front 5500 Shock 8	55351	Dual Stabilizer Mounting Kit	
5 4.5" Front / 4.5" Rear 10 Long Arm Kit Front Coils & Brackets Rear Blocks & Add-A-Leafs w/o top ovid Kit #213H with top ovid Kit #214H 29DK8771	2	55761	Rear 5500 Shock	55404	Dual Stabilizer Cylinder (2 req'd)	
	1	032503	Front Coil Springs	122501	Carrier Bearing Drop	
	1	012511	Long Arm Kit - box 1 of 2	95750	FOX Front Gas Shock (2 req'd) 9b	
	1	012513	Long Arm Kit - box 2 of 2	95761	FOX Rear Gas Shock (2 req'd)	
	1	012456	2" Block & Add-A-Leaf Kit w/o top mounted overload or			
	1	012457	2" Block & Add-A-Leaf Kit with top mounted overload			
	1	55417	Single Steering Stabilizer			
	2	55750	Front 5500 Shock			
	2	55761	Rear 5500 Shock			

Notes

- For models built after February 9, 1994 due to track bar stud size.
- Dual stabilizer may be used in place of single steering stabilizer. Dual stabilizer only fits 3-1/4" diameter axle tubes.
- May require exhaust modification.
- #002209 and 002458 rear springs come with OE style bushings installed.

- The main header is critical in selecting the proper system. Be sure to pay close attention to listings like Gas, Diesel, 2WD, 4WD, 4-Door, etc.
- Both front & rear lift dimensions are given. Always measure the vehicle before selecting a kit to achieve the desired effect. Do you want it level, tail high, tail low?
- Some applications are available in different versions - ie. Long arm, 4-Link, Standard System, Ultimate Kit.
- These are general descriptions of how the vehicle is lifted so you can make the proper selection. Do you want new rear springs, or a block and add-a-leaf?
- The kit # given includes all items listed in the required components section with hydraulic shocks. Be sure to read the notes to find out if anything additional is required. It is always our goal to include every thing you need to properly lift your vehicle in the application, but if anything additional is required it will be in the notes. Kits denoted with #XXXF utilize Fox 2.5 Remote Coil-Overs and Fox 2.0 rear shocks.
- This section indicates the required parts to properly lift your vehicle and the quantity of each of these components required. Each individual box is available separately.
- Certain applications will ask critical questions to ensure that you get the proper components for your vehicle. Be sure to physically inspect the vehicle prior to selecting your kit to ensure that you get the correct system.
- All kits are listed with the 5500 series hydraulic shocks. These can be upgraded to the new **FOX** 2.0 series shocks listed in the Optional Accessories section.
- The Optional Accessories section is used to list two different types of products. This section includes both accessories and items that are not needed on all vehicles.
 - Accessories like dual shocks, dual stabilizers, ladder bars, etc.. are listed with each application so you don't have to waste time looking them up elsewhere in the catalog.
 - Items that are not required for all vehicles are also listed in the Accessories Section. For example, not all Dodge trucks come with a carrier bearing. If your vehicle has a carrier bearing and you experience a drive line vibration after installation, then the appropriate carrier bearing drop is listed here.

In Optional Accessories
Look for **FOX** Shocks!

see pages 118-120 for details

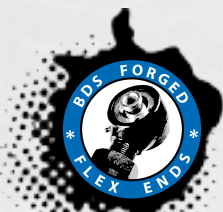

Look for this stamp indicating
kits that utilize the new
BDS Forged Flex Ends!



The NHTSA's Federal Motor Vehicle Safety Standard (FMVSS) No.126 requires all new passenger vehicles to include Electronic Stability Control (ESC) systems that meet certain standards tested through a comprehensive series of evasive maneuvers. Aftermarket products must meet these standards as well. BDS Suspension leads the industry having independently tested and proven ESC System compliance of numerous suspension systems for Ford, GM, Dodge, and Jeep vehicles. Look for the "compliant" symbol next to kit applications that have tested and meet FMVSS #126 requirements.

BDS Suspension is Hitting the Trails, Track, Shows and SEMA This Year. We'll See You Out There!

2014 EVENTS

Easter Jeep Safari
Moab, UT

Jeep Beach
Daytona Beach, FL

Blessing of the Jeeps
Mesick, MI

4-Wheel Jamboree Series
Lima, IN • Bloomsburg, PA • Indianapolis, IN

2014 Ultimate Adventure
TBD Location



PA Jeep Show
York, PA

Carlisle Truck Nationals
Carlisle, PA

Scheid Diesel Extravaganza
Terre Haute, IN

4x4 Outback Adventure
Eau Claire, PA

World Championships
Crandon, WI

Off-Road Expo
Pomona, CA

SEMA Show
Las Vegas, NV

For the full list of events and to submit your own, head to
bds-suspension.com/calendar



Follow us on for up-to-date event coverage and more





Introducing Factory Protection Plus, the ultimate lifted suspension protection coverage and BDS Suspension now includes it with each and every lift kit. Factory Protection Plus brings together BDS Suspension's exclusive No Fine Print Warranty plus FMVSS No.126 ESC System Compliance Testing plus a 5 Year / 60,000 Mile Supplemental Drivetrain Warranty. Vehicle may be eligible for parts or all of Factory Protection Plus depending on age of the vehicle and best part about it, it's FREE!



FACTORY PROTECTION PLUS FEATURES:

- 5 Year, 60,000 Mile Protection
- Free, no cost protection for BDS Suspension customers
- Could save thousands of dollars on possible repairs
- Easy online application process
- Available for most late model vehicles



WHAT IS FMVSS NO.126?

When you see the FMVSS Compliant Symbol you will know with confidence this application has been tested and successfully passed the Federal Motor Vehicle Safety Standard No. 126 compliance test. This highly specialized test was performed to prove the installation of the particular BDS Suspension system, with specified wheel and tire package will not compromise the performance and effectiveness of the vehicle's Electronic Stability Control (ESC) system keeping you safer on the road.



THE 560PLUS.COM 5 YEAR / 60,000 MILE SUPPLEMENTAL DRIVETRAIN WARRANTY

A 5 year - 60,000 mile drivetrain warranty is available for BDS Suspension equipped vehicles as a Supplemental Drivetrain Limited Warranty while your vehicle is covered by the new vehicle express drivetrain limited warranty supplied by Ford, General Motors, Chrysler or Toyota. The protection applies to any BDS eligible suspension systems purchased on or after November 1st, 2013.



HOW FACTORY PROTECTION PLUS WORKS

After installing a BDS Suspension system, the owner goes to 560Plus.com and fills out a Factory Protection Plus application form. Applicant will receive acknowledgment outlining the terms of their BDS warranty and the 560Plus.com Supplemental Drivetrain Limited Warranty. That's it! The vehicle is covered.



ABOUT 560PLUS, LLC

Factory Protection Plus is a program provided by 560Plus, LLC for participating suspension companies and owners with qualifying vehicles. Go to 560Plus.com for additional information and an online application form.

**THE ULTIMATE
Lifted Suspension
Protection Coverage
and it's FREE!**

CHEVROLET/GMC



2002-2009 CHEVROLET TRAILBLAZER / GMC ENVOY 2WD/4WD UPPER STRUT MOUNT SYSTEM

DODGE

FORD

JEEP

SUZUKI

TOYOTA

- One piece upper strut mount
- One piece rear upper coil mount
- Completely bolt-on system



POSI-LOK

SHOCKS/
STEERING
STABILIZERS

APPAREL/
PROMOTIONAL

PRODUCT
SPECS

VEHICLE
SPECS



Vehicle Specs:
2" Lift Kit
31" BFG M/T
16" stock wheels

2002-2009 CHEVROLET TRAILBLAZER / GMC ENVOY 2WD/4WD

Lift & Method	Qty	Part#	Description	Recommended Upgrades	Notes
2" Front / 2" Rear	1	011201	Box Kit	98224619 FOX 2.0 Rear Gas Shock (2 req'd)	1
Upper Strut Mount	2	55619	Rear 5500 Shock		2
Rear Coil Mount					3
Kit #168H					4
50CK334					

Notes

1. Strut compressor required for installation
2. Will not fit vehicles equipped with rear air-ride system
3. Will fit Ext and XL models
4. Front only kit available as part #121201

CHEVROLET S-10 TRUCK & BLAZER - 4WD/ GMC S-15 TRUCK & JIMMY - 4WD IFS SYSTEM

CHEVROLET/
GMC

DODGE

FORD

JEEP

SUZUKI

TOYOTA

POSI-LOK

SHOCKS/
STEERING
STABILIZERS

APPAREL/
PROMOTIONAL

PRODUCT
SPECS

VEHICLE
SPECS

Vehicle Specs:
5" Lift Kit
2" Body Lift
33" Hankook M/T
15" AR Wheels



5" Kit Features

- One piece front & rear crossmembers increase frame rigidity while reducing installation time
- Differential skid plate included to protect your differential and lock the front and rear crossmembers together
- No welding required
- Heavy-duty upper control arms included for rigidity and to increase shock clearance (#121010 available separately)
- Differential drop included to rotate the differential for proper drive-line angles
- Dropped center steering link supplied to maintain factory steering angles

1995-2005 CHEVROLET S-10 TRUCK & BLAZER - 4WD / GMC S-15 TRUCK & JIMMY - 4WD (EXCEPT ZR2/HIGHRIDER MODELS)

Lift & Method	Qty	Part#	Description	Recommended Accessories	Notes
5" Front / 4.5" Rear	1	021502	Front Box Kit 1 of 2	55414 Single 5500 Steering Stabilizer	1
IFS System	1	021503	Front Box Kit 2 of 2	121508 Rear Sway Bar Links	2
Rear Spring Over Kit	1	121010	Upper Control Arm Kit	121507 Rear Sway Bar Links	3
Kit #165H	1	011506	Rear Spring Over Kit	PSL500 4x4 Posi-Lok™ (page 119)	4
74CK7402	2	55610	Front 5500 Shock		5
	2	55608	Rear 5500 Shock		6

1988-1994 CHEVROLET S-10 TRUCK & BLAZER - 4WD / GMC S-15 TRUCK & JIMMY - 4WD (EXCEPT ZR2/HIGHRIDER MODELS)

Lift & Method	Qty	Part#	Description	Recommended Accessories	Notes
5" Front / 4.5" Rear	1	021502	Front Box Kit 1 of 2	55414 Single 5500 Steering Stabilizer	1
IFS System	1	021504	Front Box Kit 2 of 2	PSL500 4x4 Posi-Lok™ (page 119)	2
Rear Spring Over Kit	1	121010	Upper Control Arm Kit	121508 Rear Sway Bar Links	3
Kit #166H	1	011506	Rear Spring Over Kit	121507 Rear Sway Bar Links	4
56CK9902	2	55610	Front 5500 Shock		5
	2	55608	Rear 5500 Shock		

Notes

1. Requires exhaust modification.
2. Special tool required to unload/load the torsion bars. Not available through BDS.
3. Frame bracket modifications required.
4. Some Jimmy/Blazers have rear sway bars. For stem-to-eye style sway bar links order 121508. For the eye-to-eye style order 121507.
5. #55414 stabilizer kit only works in combination with the 5" BDS Suspension System.
6. Will fit ZR-5 4 Door model.

ACCESSORIES



CHEVROLET S-10 TRUCK & BLAZER ZR2/ GMC S-15 TRUCK & JIMMY ZR2 IFS SYSTEM

5" Kit Features

- "No Flex" drop drag link
- Differential drop kit for factory driveline angles
- Correct angle rear spring over axle conversion
- Brake line relocation brackets—no bleeding of brakes required
- Front anti-sway bar relocation brackets for factory handling characteristics
- One piece lower rear crossmember increases frame rigidity while reducing installation time
- Heavy duty upper control arms to increase shock clearance (#121010 available separately)



Vehicle Specs:
5" Lift Kit
33" BFG A/T
15" Steel Wheels

1996-2004 CHEVROLET BLAZER / GMC JIMMY with RPO ZR2 Wide Stance Package

Lift & Method	Qty	Part#	Description	Recommended Accessories	Notes
5" Front / 4.5" Rear	1	021500	Front Box Kit 1 of 2	55414 Single 5500 Steering Stabilizer	1
IFS System	1	021501	Front Box Kit 2 of 2	PSL500 4x4 Posi-Lok™ (page 119)	2
Rear Spring Over Axle	1	121010	Control Arm Kit		3
Kit #163H	1	011508	Rear Box Kit		4
25CK8622	2	55610	Front 5500 Shock		5
	2	55608	Rear 5500 Shock		

1995-2004 CHEVROLET S-10 TRUCK / GMC S-15 TRUCK RPO ZR2 4WD

Lift & Method	Qty	Part#	Description	Recommended Accessories	Notes
5" Front / 4.5" Rear	1	021500	Front Box Kit 1 of 2	55414 Single 5500 Steering Stabilizer	1
IFS System	1	021501	Front Box Kit 2 of 2	PSL500 4x4 Posi-Lok™ (page 119)	2
Rear Spring Over Axle	1	121010	Control Arm Kit		3
Kit #164H	1	011509	Rear Box Kit		4
97CK2922	2	55610	Front 5500 Shock		5
	2	55608	Rear 5500 Shock		

Notes

1. Requires exhaust modification.
2. Special tool (Kent Moore Tools Part #J-36202-A) required to unload/load the torsion bars. Not available through BDS.
3. Requires frame bracket modification.
4. Front drive shaft may be required.
5. #55414 stabilizer kit only works in combination with the 5" BDS Suspension System.

ACCESSORIES

#PSL500



4x4 Posi-Lok
POSITION AND ALIGNMENT

2014 CHEVROLET/GMC 1500 PICKUP 4WD WITH ALUMINUM CONTROL ARMS IFS SYSTEM

CHEVROLET/
GMC

DODGE

FORD

JEEP

SUZUKI

TOYOTA

POSI-LOK

SHOCKS/
STEERING
STABILIZERS

APPAREL/
PROMOTIONAL

PRODUCT
SPECS

VEHICLE
SPECS

4" & 6" Kit Features

- Advanced High Clearance design to maximize ground clearance and increase performance
- New custom valved gas strut included
- Ductile cast iron steering knuckle maintains optimal steering geometry
- Differential skid plate and front skid plate included for offroad protection
- Stock wheels with stock tires can be reinstalled



Vehicle Specs:
4" lift kit
35" Atturo M/T
20" AR Style 901



#710H - 6" Kit



The Fox 2.5 Coil Overs Provide the Ultimate Upgrade to the Already High-Performance BDS System

- Smooth-bore, clear coated, zinc plated alloy body
- Black anodized 6061-T6 billet aluminum mounting components
- 7/8" hard chrome plated heat treated alloy steel shaft
- High flow piston design with specially formulated race oil
- External reservoir separates shock oil from high-pressure nitrogen
- Easy bolt-on installation, no need to adjust coil spring preload

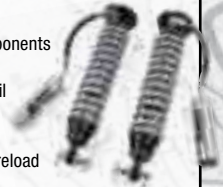

2014 CHEVROLET/GMC 1500 4WD with Aluminum Control Arms

Lift & Method	Qty	Part#	Description	Recommended Accessories	Notes	
2" Front / 0" Rear Upper Strut Mount Kit #714H 62CK531	1	021202	2" Leveling Kit	55719 98224719	Rear 5500 Shock (2 req'd) FOX Rear Gas Shock (2 req'd)	1
4" Front / 4" Rear IFS System Block Kit Kit #713H 66CK1091	1 1 1 1 2	021462 021663 021661 011405 98144 55759	Front Box Kit 1 of 2 Front Box Kit 1 of 2 Knuckle Box Kit - Aluminum Rear Block Kit Front Struts Rear 5500 Shock	98224759 121619	FOX Rear Gas Shock (2 req'd) Traction Bar Kit	1 2 3 4 5
4" Front / 4" Rear Rear Leaf Spring Kit #716H 15CK7822	1 1 1 1 2 2	021462 021663 021661 011456 001559 98144 55759	Front Box Kit 1 of 2 Front Box Kit 1 of 2 Knuckle Box Kit - Aluminum Rear Box Kit Rear Leaf Spring Front Struts Rear 5500 Shock			
6" Front / 4.5" Rear IFS System Rear Block Kit Kit #711H 89CK3191 Fox Performance System Kit #711F 90CK7033	1 1 1 1 1 2 2	021662 021663 021661 011505 98164 88302059 55759 98224759	Front Box Kit 1 of 2 Front Box Kit 1 of 2 Knuckle Box Kit - Aluminum Rear Block Kit Front Struts or FOX 2.5 Remote Coil Over Kit Rear 5500 Shock or FOX 2.0 Rear Gas Shock	98224759 121619	FOX Rear Gas Shock (2 req'd) Traction Bar Kit	1 2 3 4 5
6" Front / 5.5" Rear IFS System Rear Leaf Spring Kit #718H 15CK7822 Fox Performance System Kit #718F 26CK0863	1 1 1 1 2 1 2	021662 021663 021661 011558 001557 98164 88302059 55759 98224759	Front Box Kit 1 of 2 Front Box Kit 2 of 2 Knuckle Box Kit - Aluminum Rear Box Kit Rear Leaf Spring Front Struts or FOX 2.5 Remote Coil Over Kit Rear 5500 Shock or FOX 2.0 Rear Gas Shock			2 3 4 5



#121619 - Traction Bar Kit

Notes

1. Strut compressor required for installation
2. Requires frame bracket modification
3. Requires differential modification to clear electric power steering
4. Vehicles came with steel or aluminum steering knuckles and control arms, must order appropriate kit
5. Trimming may be required for 35" tire clearance due to variation between tire brands.

2014 CHEVROLET/GMC 1500 PICKUP 4WD WITH STEEL CONTROL ARMS IFS SYSTEM

DODGE

FORD

JEEP

SUZUKI

TOYOTA

POSI-LOK

SHOCKS/
STEERING
STABILIZERS

APPAREL/
PROMOTIONAL

PRODUCT
SPECS

VEHICLE
SPECS

2014 CHEVROLET/GMC 1500 4WD with Steel Control Arms							
Lift & Method	Qty	Part#	Description	Recommended Accessories		Notes	
2" Front / 0" Rear Upper Strut Mount Kit #714H 62CK531	1	021202	2" Leveling Kit	55719 98224719	Rear 5500 Shock (2 req'd) FOX Rear Gas Shock (2 req'd)	1	
4" Front / 4" Rear IFS System Block Kit Kit #712H 66CK1091	1 1 1 1 2	021462 021663 021660 011405 98144 55759	Front Box Kit 1 of 2 Front Box Kit 1 of 2 Knuckle Box Kit - Steel Rear Block Kit Front Struts Rear 5500 Shock	98224759 121619	FOX Rear Gas Shock (2 req'd) Traction Bar Kit	1 2 3 4 5	
4" Front / 4" Rear Rear Leaf Spring Kit #715H 15CK7822	1 1 1 1 2 1 2	021462 021663 021660 011456 001559 98144 55759	Front Box Kit 1 of 2 Front Box Kit 1 of 2 Knuckle Box Kit - Steel Rear Box Kit Rear Leaf Spring Front Struts Rear 5500 Shock	 <p>ACCESSORIES</p> <p>#121619 - Traction Bar Kit</p>			
6" Front / 4.5" Rear IFS System Block & Add-A-Leaf Kit #710H 89CK3191	1 1 1 1 1	021662 021663 021660 011505 98164	Front Box Kit 1 of 2 Front Box Kit 1 of 2 Knuckle Box Kit - Steel Rear Block Kit Front Struts or				
Fox Performance System Kit #710F 90CK7033	1 2 2	88302059 55759 98224759	FOX 2.5 Remote Coil Over Kit Rear 5500 Shock or FOX 2.0 Rear Gas Shock	<p><i>Notes</i></p> <ol style="list-style-type: none"> 1. Strut compressor required for installation 2. Requires frame bracket modification 3. Requires differential modification to clear electric power steering 4. Vehicles came with steel or aluminum steering knuckles and control arms, must order appropriate kit 5. Trimming may be required for 35" tire clearance due to variation between tire brands. 		2 3 4 5	
6" Front / 5.5" Rear IFS System Rear Leaf Spring Kit #717H 15CK7822	1 1 1 2 1 2 2	021662 021663 021660 011557 001559 98164 88302059 55759 98224759	Front Box Kit 1 of 2 Front Box Kit 2 of 2 Knuckle Box Kit - Steel Rear Box Kit Rear Leaf Spring Front Struts or FOX 2.5 Remote Coil Over Kit Rear 5500 Shock or FOX 2.0 Rear Gas Shock				
Fox Performance System Kit #717F 26CK0863	1 2 2	88302059 55759 98224759	FOX 2.5 Remote Coil Over Kit Rear 5500 Shock or FOX 2.0 Rear Gas Shock				

6" Performance System Kit Features

- Advanced High Clearance design to maximize ground clearance
- FOX Racing 2.5 Remote Reservoir Coilovers and rear FOX 2.0 Shocks for unmatched offroad performance.
- Ductile cast iron steering knuckle maintains optimal steering geometry
- 3-point differential mounting system to securely reposition front axle
- Differential skid plate and front skid plate included for offroad protection
- Stock wheels with stock tires can be reinstalled

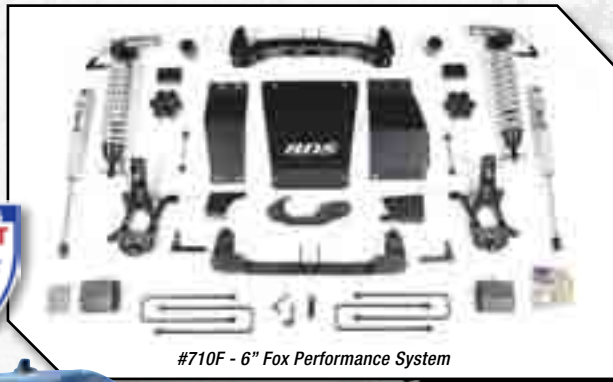

Vehicle Specs:
6" Lift Kit
35" M/T ATZ
20" D/C Gunmetal 7

2007-2013 CHEVY SILVERADO 1500 4WD TRUCK / GMC SIERRA 1500 4WD TRUCK & DENALI 1500 4WD TRUCK IFS SYSTEM

CHEVROLET/
GMC

DODGE

FORD

JEEP

SUZUKI

TOYOTA

POSI-LOK

SHOCKS/
STEERING
STABILIZERS

APPAREL/
PROMOTIONAL

PRODUCT
SPECS

VEHICLE
SPECS



4" & 6" Kit Features

- Advanced High Clearance design to maximize ground clearance and increase performance
- New custom valved gas strut included
- Ductile cast iron steering knuckle maintains optimal steering geometry
- Differential skid plate and front skid plate included for offroad protection
- Stock wheels with stock tires can be reinstalled

Vehicle Specs:
6" C/O Lift Kit
1.5" Body Lift
37" Interco M-16
20" Eagle Alloy 178s





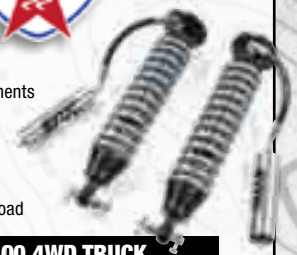

The Fox 2.5 Coil Overs Provide the Ultimate Upgrade to the Already High-Performance BDS System

- Smooth-bore, clear coated, zinc plated alloy body
- Black anodized 6061-T6 billet aluminum mounting components
- 7/8" hard chrome plated heat treated alloy steel shaft
- High flow piston design with specially formulated race oil
- External reservoir separates shock oil from high-pressure nitrogen
- Easy bolt-on installation, no need to adjust coil spring preload



2007-2013 CHEVROLET SILVERADO 1500 4WD TRUCK / GMC SIERRA 1500 4WD TRUCK & DENALI 1500 4WD TRUCK

Lift & Method	Qty	Part#	Description	Recommended Accessories	Notes
2" Front / 0" Rear Upper Strut Mount Kit #167H 62CK531	1	021201	Front Strut Mounts	55719	1
				98224719	2
4" Front / 4" Rear IFS System Block Kit Kit #184H 30CK2671 	1	021640	Front Box Kit 1 of 2	121619	1
	1	021644	Front Box Kit 2 of 2	98224758	2
	1	121613	Front Skid Plate	121651	4
	1	011457	Rear Block Kit		5
	1	98141	Rear Block Kit		6
	1	98141	Front Struts		7
	2	55758	Rear 5500 Shock		8
4" Front / 4" Rear IFS System Rear Leaf Springs Kit #185H 98CK5712 	1	021640	Front Box Kit 1 of 2	121619	1
	1	021644	Front Box Kit 2 of 2	98224758	2
	1	121613	Front Skid Plate	121651	3
	1	011458	Rear Box Kit		4
	2	001559	Rear Leaf Spring		5
	1	98141	Front Struts		6
	2	55758	Rear 5500 Shock		7
					8
6" Front / 4.5" Rear IFS System Block & Add-A-Leaf Kit #176H 74CK3771  Fox Performance System Kit #176F 04CK1323	1	021640	Front Box Kit 1 of 2	98224759	1
	1	021644	Front Box Kit 2 of 2	101002	2
	1	121613	Front Skid Plate	121619	4
	1	011559	Block & Add-A-Leaf Kit	121619	5
	1	98161 or 88302059	Front Struts or FOX 2.5 Coilover Kit	121651	6
	2	55759 or 98224759	Rear 5500 Shock or FOX 2.0 Rear Gas Shock		7
	2	55759 or 98224759	Rear 5500 Shock or FOX 2.0 Rear Gas Shock		8
6" Front / 5.5" Rear IFS System Rear Leaf Springs Kit #177H 98CK5712 Fox Performance System Kit #177F 28CK3363 	1	021640	Front Box Kit 1 of 2		1
	1	021644	Front Box Kit 2 of 2		2
	1	121613	Front Skid Plate		3
	2	001559	Rear Leaf Spring		4
	1	011558	Rear Box Kit		5
	1	98161 or 88302059	Front Struts or FOX 2.5 Coilover Kit		6
	2	55759 or 98224759	Rear 5500 Shock or FOX 2.0 Rear Gas Shock		7
	2	55759 or 98224759	Rear 5500 Shock or FOX 2.0 Rear Gas Shock		8



Notes

1. Strut compressor required for installation
2. This system will not fit 2007 classic models
3. Installation of rear leaf springs requires removal of fuel tank
4. Requires frame bracket modification
5. 20" wheels with 5" to 5-3/4" backspacing recommended to reduce trimming.
6. Traction bars will not fit regular cab short box models.
7. Add 121651 Auxiliary Differential support bracket for AWD models. Also may require front driveline modification.
8. Will not fit two-mode hybrid models with electronic power steering.

2007-2014 CHEVY TAHOE, SUBURBAN, AVALANCHE 1500 4WD / GMC YUKON, YUKON XL 1500 4WD IFS SYSTEM



4" & 6" Kit Features

- Advanced High Clearance design to maximize ground clearance and increase performance
- New custom valved gas strut included
- Ductile cast iron steering knuckle maintains optimal steering geometry
- Rack & Pinion system is retained in the stock position
- Differential skid plate and front skid plate are included for offroad protection
- Rear adjustable upper control arms included to properly adjust pinion angle
- Rear Pro-Ride coils included (6" kit only) for on road ride quality as well as offroad performance

2007-2014 CHEVROLET TAHOE, SUBURBAN, AVALANCHE 1500 4WD / GMC YUKON, YUKON XL 1500 4WD

Lift & Method	Qty	Part#	Description	Recommended Accessories	Notes	
2" Front / 0" Rear Upper Strut Mount Kit #167H 62CK531	1	021201	Front Strut Mounts	55719 98224719	Rear 5500 Shock (2 req'd) FOX 2.0 Rear Gas Shock (2 req'd)	1 2 3 7
4" Front / 2" Rear IFS System Rear Coil Spacer Kit #188H 65CK6371	1 1 1 1 2	021640 021644 121613 021209 98141 55719	Front Box Kit 1 of 2 Front Box Kit 2 of 2 Front Skid Plate Rear Box Kit Front Struts Rear 5500 Shock	98224719 121651	FOX 2.0 Rear Gas Shock (2 req'd) Auxiliary Differential Bracket	1 2 3 4 5 6 8
4" Front / 3" Rear IFS System Rear Coil Spacer Kit #900H 97CK1791	1 1 1 1 2	021640 021644 121613 021309 98141 55719	Front Box Kit 1 of 2 Front Box Kit 2 of 2 Front Skid Plate Rear Box Kit Front Struts Rear 5500 Shock	98224719 121651	FOX 2.0 Rear Gas Shock (2 req'd) Auxiliary Differential Bracket	1 2 3 4 5 6 8
6" Front / 5" Rear IFS System Rear Coil Spring Kit #178H 44CK1932 Fox Performance System Kit #178F 73CK9483	1 1 1 1 1 2 2	021640 021644 121613 021609 98161 or 88302059 55759 or 98224759	Front Box Kit 1 of 2 Front Box Kit 2 of 2 Front Skid Plate Rear Box Kit Front Struts or FOX 2.5 Coilover Kit Rear 5500 Shock or FOX 2.0 Rear Gas Shock	98224759 101002 121651	FOX 2.0 Rear Gas Shock (2 req'd) Front Stainless Brake Lines Auxiliary Differential Bracket	1 2 3 4 5 6 8

Notes

1. Will not work with auto-ride equipped vehicles.
2. This system will only fit 2007 new body style.
3. Strut compressor required for installation.
4. Minor premature engagement of the stabiltrak system may occur during certain driving maneuvers.
5. Minor frame bracket modification and welding required.
6. 20" wheels with 5" to 5-3/4" backspacing recommended to reduce trimming.
7. 2" system also fits 2WD models.
8. Add 121651 Auxiliary Differential bracket for AWD models. Also may require front driveline modification.

Upper Strut Mount

- Upper strut mounts maintain factory ride while increasing ground clearance.
- Includes pre-load spacer to compensate for heavy aftermarket tires.
- Doesn't max out droop like other leveling kits.



Vehicle Specs:
6" Coilover System
35" M/T ATZ P3
20" Fuel Octanes

2007-2013 SILVERADO 1500 2WD TRUCK / GMC SIERRA 1500 2WD TRUCK IFS SYSTEM

CHEVROLET/
GMC

DODGE

FORD

JEEP

SUZUKI

TOYOTA

POSI-LOK

SHOCKS/
STEERING
STABILIZERS

APPAREL/
PROMOTIONAL

PRODUCT
SPECS

VEHICLE
SPECS



4" & 6" Kit Features

- Advanced High Clearance design to maximize ground clearance and increase performance
- 91% increase in ground clearance at front crossmember on 6" system
- New custom valved offroad replacement struts included
- Ductile cast iron steering knuckle maintains optimal steering geometry
- Full belly pan included for offroad protection as well as optional front skid plate





#121613 stainless steel skid plate



Vehicle Specs:
6" Lift Kit
35" D/C M/T
20" Eagle Alloy

2007-2013 CHEVROLET SILVERADO 1500 2WD TRUCK / GMC SIERRA 1500 2WD TRUCK

Lift & Method	Qty	Part#	Description	Recommended Accessories	Notes
2" Front / 0" Rear Upper Strut Mount Kit #167H 62CK531	1	021201	Front Strut Mounts	55719	1
				98224719	2
4" Front / 4" Rear IFS System Block Kit Kit #186H 43CK5051	1	021640	Front Box Kit 1 of 2	121613	1
	1	021643	Front Box Kit 2 of 2	98224758	2
	1	011457	Block Kit	121619	3
	1	98141	Front Struts		4
	2	55758	Rear 5500 Shock		5
4" Front / 4" Rear IFS System Rear Leaf Springs Kit #187H 02CK9191	1	021640	Front Box Kit 1 of 2		
	1	021643	Front Box Kit 2 of 2		
	1	011458	Rear Box Kit		
	2	001559	Rear Leaf Spring		
	1	98141	Front Struts		
6" Front / 4.5" Rear IFS System Block & Add-A-Leaf Kit #174H 87CK6151 Fox Performance System Kit #174F 17CK4792	1	021640	Front Box Kit 1 of 2	98224759	1
	1	021643	Front Box Kit 2 of 2	101002	2
	1	011559	Block & Add-A-Leaf Kit	121613	3
	1	98161 or 88302059	Front Struts or FOX 2.5 Coilover Kit	121619	4
	2	55759 or 98224759	Rear 5500 Shock or FOX 2.0 Rear Gas Shock		5
	6" Front / 5.5" Rear IFS System Rear Leaf Springs Kit #175H 02CK9191 Fox Performance System Kit #175F 31CK7733	1	021640	Front Box Kit 1 of 2	
1		021643	Front Box Kit 2 of 2		
2		001559	Rear Leaf Spring		
1		011558	Rear Box Kit		
1		98161 or 88302059	Front Struts or FOX 2.5 Coilover Kit		
2		55759 or 98224759	Rear 5500 Shock or FOX 2.0 Rear Gas Shock		
					

Shown in gray with optional #121613 skid plate

Notes

1. Strut compressor required for installation
2. This system will not fit 2007 classic models
3. 20" wheels with 5" to 5-3/4" backspacing recommended to reduce trimming.
4. Will not fit two-mode hybrid models with electronic power steering.
5. Will not work on extended/crew cab long box

FOX PERFORMANCE
COILOVER SYSTEM

1999-2006 CHEVROLET SILVERADO 1500 4WD TRUCK / GMC SIERRA & DENALI 1500 4WD TRUCK IFS SYSTEM









4.5" & 6.5" Kit Features

- Advanced high clearance design to maximize ground clearance and increase performance
- No torsion bar drop system to maximize ground clearance
- Front skid plate and differential skid plate included for off-road protection
- Ductile iron steering knuckles maintain optimal steering geometry



Vehicle Specs:
6.5" Lift Kit
35" D/C Mud Country
20" Eagle Alloy 178

1999-2006 CHEVROLET SILVERADO 1500 4WD TRUCK / GMC SIERRA & DENALI 1500 4WD TRUCK

Lift & Method	Qty	Part#	Description	Recommended Accessories	Notes	
4.5" Front / 3" Rear IFS System Block Kit Kit# 181H 09CK7771  	1	021610	Front Knuckle Kit	page 128	Steering Stabilizers	1
	1	021626	Main Box Kit	98224602	FOX 2.0 Front Gas Shock (2 req'd)	2
	1	021450	Torsion Bar System	98224758	FOX 2.0 Rear Gas Shock (2 req'd)	3
	1	121614	Front Skid Plate			4
	1	011457	Rear Block Kit			5
	2	55602	Front 5500 Shock			6
	2	55758	Rear 5500 Shock			
4.5" Front / 3.5" Rear IFS System Rear Leaf Spring Kit# 182H 67CK1912  	1	021610	Front Knuckle Kit	page 128	Steering Stabilizers	1
	1	021626	Main Box Kit	98224602	FOX 2.0 Front Gas Shock (2 req'd)	2
	1	021450	Torsion Bar System	98224758	FOX 2.0 Rear Gas Shock (2 req'd)	3
	1	121614	Front Skid Plate			4
	2	001559	Rear Leaf Spring	121619	Traction Bars	5
	1	011458	Rear Box Kit			6
	2	55602	Front 5500 Shock			
2	55758	Rear 5500 Shock				
6.5" Front / 4" Rear IFS System Block & Add-a-Leaf Kit# 179H 43CK9871  	1	021610	Front Knuckle Kit	page 128	Steering Stabilizers	1
	1	021626	Main Box Kit	98224602	FOX 2.0 Front Gas Shock (2 req'd)	2
	1	021617	Torsion Bar System	98224759	FOX 2.0 Rear Gas Shock (2 req'd)	3
	1	121614	Front Skid Plate			4
	1	011559	Block & Add-a-Leaf Kit	121619	Traction Bars	5
	2	55602	Front 5500 Shock			6
	2	55759	Rear 5500 Shock			
6.5" Front / 5.5" Rear IFS System Rear Leaf Spring Kit# 180H 67CK1912  	1	021610	Front Knuckle Kit	page 128	Steering Stabilizers	1
	1	021626	Main Box Kit	98224602	FOX 2.0 Front Gas Shock (2 req'd)	2
	1	021617	Torsion Bar System	98224759	FOX 2.0 Rear Gas Shock (2 req'd)	3
	1	121614	Front Skid Plate			4
	2	001559	Leaf Spring	121619	Traction Bars	5
	1	011558	Rear Box Kit			6
	2	55602	Front 5500 Shock			
2	55759	Rear 5500 Shock				

Notes

1. Special tool (Kent Moore Tools Part# J-42393) required to unload/load torsion bars. Not available through BDS.
2. Requires frame bracket modification and differential mount modification as well as minor welding.
3. Will not fit heavy duty (HD) models.
4. If equipped with stock 17" wheels, then must replace with 17" or larger aftermarket wheels.
5. AWD models will require front driveline modification.
6. Traction bars will not fit standard cab or short box trucks

2000-2006 CHEVROLET K1500 SUBURBAN, YUKON, TAHOE, AVALANCHE, ESCALADE - 4WD/AWD IFS SYSTEM

CHEVROLET/
GMC

DODGE

FORD

JEEP

SUZUKI

TOYOTA

POSI-LOK

SHOCKS/
STEERING
STABILIZERS

APPAREL/
PROMOTIONAL

PRODUCT
SPECS





VEHICLE
SPECS



4.5" & 6.5" Kit Features

- Advanced high clearance design to maximize ground clearance and increase performance
- No torsion bar drop system to maximize ground clearance
- Front skid plate and differential skid plate included for off-road protection
- Ductile iron steering knuckles maintain optimal steering geometry



2000-2006 CHEVROLET K1500 SUBURBAN, YUKON, TAHOE, AVALANCHE, ESCALADE - 4WD / AWD						
Lift & Method	Qty	Part#	Description	Recommended Accessories	Notes	
4.5" Front / 3.5" Rear IFS System Rear Coil Spacer Kit# 191H 07CK4491  	1	021610	Front Knuckle Kit	121400	Auto-Ride Systems	1
	1	021626	Main Box Kit	page 128	Steering Stabilizers	2
	1	021450	Torsion Bar System	98224602	FOX 2.0 Front Gas Shock (2 req'd)	3
	1	121614	Front Skid Plate	98224719	FOX 2.0 Rear Gas Shock (2 req'd)	4
	1	021359	Rear Box Kit			5
	2	55602	Front 5500 Shock			6
	2	55719	Rear 5500 Shock			7
6.5" Front / 6" Rear IFS System Rear Coil Kit# 183H 40CK3791  	1	021610	Front Knuckle Kit	121011	Auto-Ride Systems	1
	1	021626	Main Box Kit	page 128	Steering Stabilizers	2
	1	021617	Torsion Bar System	98224602	FOX 2.0 Front Gas Shock (2 req'd)	3
	1	121614	Front Skid Plate	98224759	FOX 2.0 Rear Gas Shock (2 req'd)	4
	1	021608	Rear Box Kit			5
	2	55602	Front 5500 Shock			6
	2	55759	Rear 5500 Shock			7

Notes

1. Special tool (Kent Moore Tools Part# J-42393) required to unload/load torsion bars. Not available through BDS.
2. Requires frame bracket modification and differential mount modification.
3. All wheel drive models will require front drive line modification.
4. If equipped with stock 17" wheels, then must replace with 17" or larger aftermarket wheels.
5. Larger tires cannot be installed on OEM wheels.
6. Auto-Ride equipped vehicles require part #121400 or #121011 in place of front and rear shocks.
7. System will not fit 2000 model Escalades.



Vehicle Specs:
6.5" Lift Kit
35" M/T ATZ
20" Eagle Alloys

1988-1998 CHEVROLET/GMC K1500, K2500 6-LUG TRUCK 4WD IFS SYSTEM

Vehicle Specs:
6" Lift Kit
35" D/C FC-II
16x10 Wheels



6" Kit Features

- Upper A-Arms with greaseable bushings included to allow for zero track width change and reduced ball joint stress and maximize tire clearance
- Heavy duty High Clearance crossmembers are locked together with a differential skid plate and additionally supported with compression struts
- Unlike others on the market, this system offers a full 6" of lift without cranking the torsion bars
- The High Clearance crossmembers combined with the heavy duty upper control arms offer better performance and improved geometry for a system that excels both on and off road!
- Stainless front brake lines included

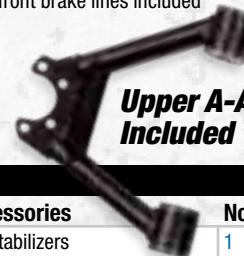

1988-1998 CHEVROLET/GMC K1500, K2500 6-LUG 4WD TRUCK

Lift & Method	Qty	Part#	Description	Recommended Accessories	Notes
6" Front / 5" Rear IFS System Rear Blocks & Add-A-Leafs Kit #193H 06CK6691	1	021602	Front Box Kit 1 of 3	Page 128	1
	1	021605	Front Box Kit 2 of 3	Steering Stabilizers	2
	1	021606	Front Box Kit 3 of 3	PSL600 4x4 Posi-Lok™ (page 119)	3
	1	011459	Rear Box Kit	PSL1000 4x4 Posi-Lok™ (page 119)	4
	2	55600	Front 5500 Shock	121619 Traction Bars (Note 8)	5
	2	55609	Rear 5500 Shock	101009 Rear Brake Line	6
6" Front / 5" Rear IFS System Rear Leaf Springs Kit #194H 49CK9822	1	021602	Front Box Kit 1 of 3	98224620 FOX 2.0 Front Gas Shock (2 req'd)	7
	1	021605	Front Box Kit 2 of 3	98224660 FOX 2.0 Rear Gas Shock (2 req'd)	8
	1	021606	Front Box Kit 3 of 3		
	2	001559	Rear Leaf Spring		
	1	011519	Rear Box Kit		
	2	55600	Front 5500 Shock		
	2	55609	Rear 5500 Shock		

Notes

1. Requires exhaust modification.
2. Special tool (Kent Moore Tools Part #J-36202-A) required to unload/load torsion bars. Not available through BDS.
3. Requires frame bracket modification and differential mount modification.
4. Not recommended for long box extended cab models due to crossmember interference.
5. All models equipped with auto-trac may require a new front driveshaft. The auto-trac New Process 246 transfer case can be identified by the silver dollar sized plaque on the rear of the transfer case that reads "NP246". The dash mounted display will display the Auto 4WD symbol. NP243 is not auto-trac.
6. Aftermarket wheels required. (see chart in back)
7. System will not work on some '88-'95 vehicles equipped with spindle mounted front ABS sensor.
8. Traction bars will not work on regular cab, short box models.

ACCESSORIES



1992-1998 CHEVROLET TAHOE & SUBURBAN, 6-LUG / GMC YUKON, 6-LUG IFS SYSTEM

CHEVROLET/
GMC

DODGE

FORD

JEEP

SUZUKI

TOYOTA

POSI-LOK

SHOCKS/
STEERING
STABILIZERS

APPAREL/
PROMOTIONAL

PRODUCT
SPECS

VEHICLE
SPECS



Vehicle Specs:
6" Lift Kit
35" D/C FC-II
16" Eagle Alloy 102

6" Kit Features

- One-piece high clearance front & rear crossmembers made from 1/4" thick steel
- Differential skid plate and compression struts included for off-road protection
- Heavy duty steering knuckle included to correct steering geometry and ease installation
- Increased caster for more control
- Stainless front brake lines included

1992-1998 CHEVROLET TAHOE, 2 DOOR 6-LUG / GMC YUKON, 2 DOOR 6-LUG

Lift & Method	Qty	Part#	Description	Recommended Accessories	Notes
6" Front / 5" Rear	1	021602	Front Box Kit 1 of 3	Page 128 Steering Stabilizers	1
IFS System	1	021605	Front Box Kit 2 of 3	PSL600 4x4 Posi-Lok™ (page 119)	2
Rear Block & Add-A-Leaf	1	021606	Front Box Kit 3 of 3	PSL1000 4x4 Posi-Lok™ (page 119)	3
Kit #193H	1	011459	Rear Box Kit	101009 Rear Brake Line	4
06CK6691	2	55600	Front 5500 Shock	124002 Rear Sway Bar Links	5
	2	55609	Rear 5500 Shock		6
					7

1992-1998 CHEVROLET TAHOE 4-DOOR 4WD, 6-LUG & SUBURBAN 6-LUG 4WD / GMC YUKON 4-DOOR, 6-LUG 4WD

Lift & Method	Qty	Part#	Description	Recommended Accessories	Notes
6" Front / 5" Rear	1	021602	Front Box Kit 1 of 3	Page 128 Steering Stabilizers	1
IFS System	1	021605	Front Box Kit 2 of 3	PSL600 4x4 Posi-Lok™ (page 119)	2
Rear Block & Add-A-Leaf	1	021606	Front Box Kit 3 of 3	PSL1000 4x4 Posi-Lok™ (page 119)	3
Kit #195H	1	011459	Rear Box Kit	101009 Rear Brake Line	4
84CK5112	1	121002	Crossmember Kit	124002 Rear Sway Bar Links	5
	2	55600	Front 5500 Shock		6
	2	55609	Rear 5500 Shock		7

Notes

1. Requires exhaust modification.
2. Special tool (Kent Moore Tools Part #J-36202-A) required to unload/load torsion bars.
Not available through BDS.
3. Requires frame bracket modification and differential mount modification.
4. All models equipped with auto-trac may require a new front driveshaft. The auto-trac New Process 246 transfer case can be identified by the silver dollar sized plaque on the rear of the transfer case that reads "NP246". The dash mounted display will display the Auto 4WD symbol. NP243 is not auto-trac.
5. Aftermarket wheels required. (See tire and wheel chart in back of catalog)
6. System will not work on some 88-95 vehicles equipped with spindle mounted front ABS sensor.
7. Four door models require 121002 Torsion Bar Crossmember Kit.

ACCESSORIES







2011-2015 CHEVROLET SILVERADO 2500/3500HD AND GMC SIERRA/DENALI 2500/3500HD IFS SYSTEM



6.5" Kit Features

- No Torsion Bar Drop design for maximum ground clearance
- High clearance laser cut crossmember
- No track width change
- Front skid plate included
- 3" Rear block kit or 5" u-bolt flip rear kit
- Stainless steel brake lines
- Ductile iron steering knuckles

2011-2015 CHEVROLET/GMC 2500/3500HD 2WD & 4WD - GAS/DIESEL

Lift & Method	Qty	Part#	Description	Recommended Accessories	Notes	
6.5" Front / 3" Rear IFS System Block Kit  Kit # 198H w/o Top Overload or Kit # 199H w/Top Overload 16CK8122 	1	021650	Front Box Kit 1 of 4	98224613	FOX 2.0 Front Gas Shock (2 req'd)	1
	1	021651	Front Box Kit 2 of 4	98224768	FOX 2.0 Rear Gas Shock (2 req'd)	2
	1	021652	Front Box Kit 3 of 4	55425	Single 5500 Steering Stabilizer	3
	1	021653	Front Box Kit 4 of 4	95425	Single 9500 Steering Stabilizer	4
	1	021654	Torsion Bar Relocation System			5
	1	121650	Front Skid Plate	121612	Carrier Bearing Drop	6
	1	011318	Rear Box Kit w/o TopOvid or			
	1	011317	Rear Box Kit w/ TopOvid			
	2	55613	Front 5500 Shocks			
	2	55768	Rear 5500 Shock			
6.5" Front / 5" Rear IFS System Block Kit  Kit # 196H w/o Top Overload or Kit # 197H w/Top Overload 48CK8032 	1	021650	Front Box Kit 1 of 4	98224613	FOX 2.0 Front Gas Shock (2 req'd)	1
	1	021651	Front Box Kit 2 of 4	98224768	FOX 2.0 Rear Gas Shock (2 req'd)	2
	1	021652	Front Box Kit 3 of 4	55425	Single 5500 Steering Stabilizer	3
	1	021653	Front Box Kit 4 of 4	95425	Single 9500 Steering Stabilizer	4
	1	021654	Torsion Bar Relocation System	121612	Carrier Bearing Drop	5
	1	121650	Front Skid Plate			6
	1	021509	Rear Box Kit w/o TopOvid or			
	1	021508	Rear Box Kit w/ TopOvid			
	2	55613	Front 5500 Shocks			
	2	55768	Rear 5500 Shock			

Notes:

1. Torsion Bar Tool required to load/unload the torsion bars.
2. Requires frame bracket and differential modification
3. 3" rear block kit recommended for dually applications, 5" rear block kit will not fit dually applications.
4. Stock 17" & 18" wheels cannot be reinstalled. Stock 20" can be used with up to a 35x12.50 tire.
5. Factory dually wheels can not be reinstalled.
6. Models with two piece rear driveshaft will require #121612.

ACCESSORIES



Vehicle Specs:
 6.5" lift kit
 35" Toyo M/T
 22" AF Wheels

2001-2010 CHEVROLET/GMC K2500 HD, K2500 NON-HD, K2500 4WD TRUCK IFS SYSTEM

CHEVROLET/
GMC

DODGE

FORD

JEEP

SUZUKI

TOYOTA

POSI-LOK

SHOCKS/
STEERING
STABILIZERS

APPAREL/
PROMOTIONAL

PRODUCT
SPECS

VEHICLE
SPECS

Vehicle Specs:
7" Lift Kit
35" D/C FC-II
18" ATX Thug







#189H - 7" Kit

4.5" Kit Features

- High clearance crossmember design
- Standard or narrow track knuckles available
- Optional front skid plate
- 3-Point differential mounting system
- Differential skid plate included

7" Kit Features

- No Torsion Bar Drop (max clearance)
- High clearance crossmember design
- Standard or narrow track knuckles
- Full 7" lift without cranking torsion bars
- Improved steering/suspension geometry
- Front and differential skid plate included
- Rear leaf springs available
- 3-Point differential mounting system

2001-2010 CHEVROLET/GMC K2500/3500 HD 4WD TRUCK						
Lift & Method	Qty	Part#	Description	Recommended Accessories		Notes
4.5" Front / 3" Rear IFS System Block Kit Kit# 192H 25CK9471 	1	021632	Standard Knuckle Kit or	55423	Dual 5500 Steering Stabilizer (2 req'd)	1
	1	021635	Narrow Track Knuckle Kit	55363	Dual Bracket Kit	2
	1	021451	Front Box Kit 2 of 3	55411	Single 5500 Steering Stabilizer	3
	1	021452	Front Box Kit 3 of 3	98224605	FOX 2.0 Front Gas Shock (2 req'd)	4
	1	011319	Rear Block Kit	98224759	FOX 2.0 Rear Gas Shock (2 req'd)	5
	2	55605	Front 5500 Shock	121618	Traction Bars	6
	2	55759	Rear 5500 Shock	121612	Carrier Bearing Drop	7
				121624	Front Skid Plate	8
						9
7" Front / 5" Rear IFS System Block Kit Kit# 189H 18CK8691  	1	021632	Standard Knuckle Kit or	55423	Dual 5500 Steering Stabilizer (2 req'd)	1
	1	021635	Narrow Track Knuckle Kit	55363	Dual Bracket Kit	2
	1	021633	Front Box Kit 2 of 3	55411	Single 5500 Steering Stabilizer	3
	1	021634	Front Box Kit 3 of 3	98224606	FOX 2.0 Front Gas Shock (2 req'd)	4
	1	011517	Rear Block Kit	98224761	FOX 2.0 Rear Gas Shock (2 req'd)	5
	2	55606	Front 5500 Shock	121618	Traction Bars	6
	2	55761	Rear 5500 Shock	121612	Carrier Bearing Drop	7
						8
						9
7" Front / 5" Rear IFS System Rear Leaf Spring Kit# 190H 51CK9162  	1	021632	Standard Knuckle Kit or	55423	Dual 5500 Steering Stabilizer (2 req'd)	1
	1	021635	Narrow Track Knuckle Kit	55363	Dual Bracket Kit	2
	1	021633	Front Box Kit 2 of 3	55411	Single 5500 Steering Stabilizer	3
	1	021634	Front Box Kit 3 of 3	98224606	FOX 2.0 Front Gas Shock (2 req'd)	4
	2	001509	Rear Leaf Spring	98224761	FOX 2.0 Rear Gas Shock (2 req'd)	5
	4	4045	Rear U-Bolts	121618	Traction Bars	6
	2	55606	Front 5500 Shock	121612	Carrier Bearing Drop	7
	2	55761	Rear 5500 Shock			8
						9

Notes

1. Torsion Bar tool required to load/unload the torsion bars.
2. Some welding required.
3. Requires frame bracket modification and differential mount modification.
4. Traction bars will not fit standard cab/short box models and are designed to work on vehicles with 4" to 8" of lift.
5. 20" wheels with 5" to 5-3/4" backspacing recommended to reduce trimming.
6. Gas models require exhaust modification.
7. Narrow track knuckle will slightly increase turning radius.
8. For tail high stance use #119157 add-a-leaf with the block kit or #069207 with leaf spring kit.
9. Dually applications will require longer u-bolts.

2001-2006 GM K1500 HD, K2500 NON-HD, K2500 SUBURBAN, K2500 AVALANCHE 4WD IFS SYSTEM

DODGE

FORD

JEEP

SUZUKI

TOYOTA

POSI-LOK





SHOCKS/
STEERING
STABILIZERS

APPAREL/
PROMOTIONAL

PRODUCT
SPECS

VEHICLE
SPECS

2001-2006 GM K1500 HD, K2500 NON-HD, K2500 SUBURBAN, K2500 AVALANCHE 4WD WITH STANDARD SHOCKS

Lift & Method	Qty	Part#	Description	Recommended Accessories	Notes	
4.5" Front / 3" Rear	1	021632	Standard Knuckle Kit or	55423	Dual 5500 Steering Stabilizer (2 req'd)	1
IFS System	1	021635	Narrow Track Knuckle Kit	55363	Dual Bracket Kit	2
Block Kit	1	021451	Front Box Kit 2 of 3	55411	Single 5500 Steering Stabilizer	3
Kit# 192H	1	021452	Front Box Kit 3 of 3	98224605	FOX 2.0 Front Gas Shock (2 req'd)	4
25CK9471	1	011319	Rear Block Kit	98224759	FOX 2.0 Rear Gas Shock (2 req'd)	5
	2	55605	Front 5500 Shock	121618	Traction Bars	6
	2	55759	Rear 5500 Shock	121612	Carrier Bearing Drop	7
				121624	Front Skid Plate	8
7" Front / 5" Rear	1	021632	Standard Knuckle Kit or	55423	Dual 5500 Steering Stabilizer (2 req'd)	1
IFS System	1	021635	Narrow Track Knuckle Kit	55363	Dual Bracket Kit	2
Block Kit	1	021633	Front Box Kit 2 of 3	55411	Single 5500 Steering Stabilizer	3
Kit# 189H	1	021634	Front Box Kit 3 of 3	98224606	FOX 2.0 Front Gas Shock (2 req'd)	4
18CK8691	2	011517	Rear Block Kit	98224761	FOX 2.0 Rear Gas Shock (2 req'd)	5
	4	55606	Front 5500 Shock	121618	Traction Bars	6
	2	55761	Rear 5500 Shock	121612	Carrier Bearing Drop	7
	2					8



#192H - 4.5" Kit

Notes

1. Torsion Bar tool required to load/unload the torsion bars.
2. Some welding required.
3. Requires frame bracket modification and differential mount modification.
4. Traction bars will not fit standard cab/short box models and are designed to work on vehicles with 4" to 8" of lift.
5. 20" wheels with 5" to 5-3/4" backspacing recommended to reduce trimming.
6. Gas models require exhaust modification.
7. Narrow track knuckle will slightly increase turning radius.
8. For tail high stance use #119157 add-a-leaf with the block kit or #069207 with leaf spring kit.



2001-2010 2WD C2500 HD IFS SYSTEM

7" Kit Features

- One-piece front & rear crossmembers increase frame rigidity while reducing installation time
- Heavy-duty steering knuckles included to correct steering geometry and ease installation
- Compression struts included for additional support
- Optional stainless steel skid plate and steering stabilizers available
- Increased ground clearance created by high arched crossmembers



2001-2010 CHEVROLET/GMC C2500 HD 2WD TRUCK

Lift & Method	Qty	Part#	Description	Recommended Accessories	Notes	
7" Front / 5" Rear	1	021620	Front Box Kit 1 of 3	55411	Single 5500 Steering Stabilizer (OE)	1
IFS System	1	021627	Front Box Kit 2 of 3	55410	Dual 5500 Steering Stabilizers (2 req'd)	2
Rear Block Kit	1	021628	Front Box Kit 3 of 3	55355	Dual Bracket Kit (1 req'd)	3
Kit #149H w/611	1	121610	Skid Plate	98224606	FOX 2.0 Front Gas Shock (2 req'd)	
Kit #150H w/612	1	121611	Carrier Bearing Drop or	98224761	FOX 2.0 Rear Gas Shock (2 req'd)	
18CK0451	1	121612	Carrier Bearing Drop			
	1	011507	Rear Block Kit			
	2	55606	Front 5500 Shock			
	2	55761	Rear 5500 Shock			

Notes

1. Special tool required to unload/load the torsion bars.
2. Will not fit non-HD applications.
3. The 2WD HD was produced with two different styles of carrier bearing crossmembers. If the carrier bearing is mounted above the crossmember, use 121611. If the carrier bearing is mounted below the crossmember, use 121612.

1988-1991 CHEVROLET BLAZER & SUBURBAN 4WD / GMC JIMMY 4WD GLIDE-RIDE SYSTEM

CHEVROLET/
GMC

DODGE

FORD

JEEP

SUZUKI

TOYOTA

POSI-LOK

SHOCKS/
STEERING
STABILIZERS

APPAREL/
PROMOTIONAL

PRODUCT
SPECS

VEHICLE
SPECS



Vehicle Specs:
6" System
315/75 R16 MTZ tires
16x7 American Racing wheels

1988-1991 CHEVROLET BLAZER & SUBURBAN 4WD / GMC JIMMY 4WD

Lift & Method	Qty	Part#	Description	Recommended Accessories	Notes
2.5" Front / 2" Rear	2	001201	Front Spring	Page 128	
Front Leaf Springs	1	011003	Front Box Kit	55620	Steering Stabilizers
Rear Blocks	1	011209	1/2 Ton Rear 2" Box Kit <i>or</i>	121001	Front 5500 Auxiliary Shock (2 req'd)
1/2 Ton Kit #135H	1	011208	3/4 Ton Rear 2" Box Kit	121005	GM Frame Support Kit
3/4 Ton Kit #136H	2	55620	Front 5500 Shock	121009	Front Spring Eye Bolts
29CK726	2	55629	Rear 5500 Shock	98224620	Rear Spring Eye Bolts
				98224629	FOX 2.0 Front Gas Shock (2 req'd)
				92824620	FOX 2.0 Rear Gas Shock (2 req'd)
					FOX 2.0 Front Gas Aux. Shock (2 req'd)
4" Front / 4" Rear	2	001401	Front Spring	Page 128	Steering Stabilizers
Front Leaf Springs	1	011003	Front Box Kit	55650	Front 5500 Auxiliary Shock (2 req'd)
Rear Blocks	1	011409	1/2 Ton Rear 4" Box Kit <i>or</i>	081402	2" Adjustable Drag Link
1/2 Ton Kit #137H	1	011408	3/4 Ton Rear 4" Box Kit	121000	Transfer Case Drop Kit
3/4 Ton Kit #138H	1	081401	Steering Arm	121001	GM Frame Support Kit
91CK857	2	55620	Front 5500 Shock	119158	Short Add-a-leaf (use in place of 119157)
	2	55639	Rear 5500 Shock	121005	Front Spring Eye Bolts
4" Front / 4" Rear	2	001401	Front Spring	121009	Rear Spring Eye Bolts
Front Leaf Springs	1	011003	Front Box Kit	121003	Front Anti-Sway Bar Drop Kit
Rear Blocks and	1	119157	Long Rear Add-a-leaf	98224620	FOX 2.0 Front Gas Shock (2 req'd)
Add-A-Leafs	1	011209	1/2 Ton Rear 2" Box Kit <i>or</i>	98224639	FOX 2.0 Rear Gas Shock (2 req'd)
1/2 Ton Kit #139H	1	011208	3/4 Ton Rear 2" Box Kit	98224650	FOX 2.0 Front Gas Aux. Shock (2 req'd)
3/4 Ton Kit #140H	1	081401	Steering Arm		
73CK528	2	55620	Front 5500 Shock		
	2	55639	Rear 5500 Shock		
4" Front / 4" Rear	2	001401	Front Spring		
Front Leaf Springs	1	011003	Front Box Kit		
Rear Leaf Springs	2	001409	Rear Spring 52" Eye to Eye		3
1/2 Ton vehicle only	1	011009	Rear Box Kit		5
Kit #141H	1	081401	Steering Arm		6
56CK4811	2	55620	Front 5500 Shock		
	2	55639	Rear 5500 Shock		
4" Front / 4" Rear	2	001401	Front Spring		
Front Leaf Springs	1	011003	Front Box Kit		
Rear Leaf Springs	2	001408	Rear Spring 56" Eye to Eye		
3/4 Ton vehicle only	4	4032	5/8 x 3-5/8 x 10" Rd U-bolt		
Kit #142H	1	081401	Steering Arm		
09CK6811	2	55620	Front 5500 Shock		
	2	55639	Rear 5500 Shock		



See Notes ►

Continued ►

1988-1991 CHEVROLET BLAZER & SUBURBAN 4WD / GMC JIMMY & SUBURBAN 4WD GLIDE-RIDE SYSTEM

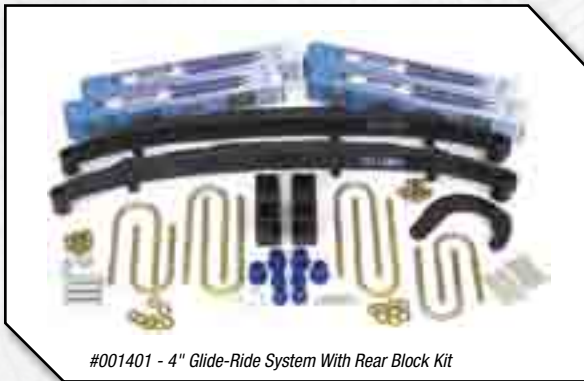

#001401 - 4" Glide-Ride System With Rear Block Kit



#001801 - 8" 1/2 Ton Glide-Ride System with Rear Springs

- Glide-Ride leaf springs feature bolt-style leaf alignment clamps, anti-friction pads and tapered leaves
- Polyurethane bushings are used for additional performance

1988-1991 CHEVROLET BLAZER & SUBURBAN 4WD / GMC JIMMY 4WD (CONTINUED)

Lift & Method	Qty	Part#	Description	Recommended Accessories	Notes	
6" Front / 6" Rear Front Leaf Springs	2	001551	Front Spring	Page 128 55650	Steering Stabilizers Front 5500 Auxiliary Shock (2 req'd)	3 5
Rear Blocks and Add-A-Leafs	1	119157	Long Rear Add-a-leaf	081402	2" Adjustable Drag Link	6
1/2 Ton Kit #143H	1	011409	1/2 Ton Rear 4" Box Kit or	121001	GM Frame Support Kit	
3/4 Ton Kit #144H 24CK459	1	011408	3/4 Ton Rear 4" Box Kit	121632	Front Anti-Sway Bar Links	
	1	081401	Steering Arm	119158	Short Add-a-leaf (use in place of 119157)	
	1	121000	Transfer Case Drop Kit	121005	Front Spring Eye Bolts	
	2	55650	Front 5500 Shock	121009	Rear Spring Eye Bolts	
	2	55639	Rear 5500 Shock	98224650	FOX 2.0 Front Gas Shock (2 req'd)	
6" Front / 6" Rear Front Leaf Springs	2	001551	Front Spring	98224639	FOX 2.0 Rear Gas Shock (2 req'd)	
Rear Leaf Springs	1	011003	Front Box Kit	98224650	FOX 2.0 Front Gas Aux. Shock (2 req'd)	
1/2 Ton vehicle only	2	001609	Rear Spring 52" Eye to Eye			
Kit #145H 24CK8031	1	011009	Rear Box Kit			
	1	081401	Steering Arm			
	1	121000	Transfer Case Drop Kit			
	2	55650	Front 5500 Shock			
	2	55639	Rear 5500 Shock			
6" Front / 6" Rear Front Leaf Springs	2	001551	Front Spring			
Rear Leaf Springs	1	011003	Front Box Kit			
3/4 Ton vehicle only	2	001608	Rear Spring 56" Eye to Eye			
Kit #146H 55CK0431	4	4032	5/8 x 3-5/8 x 10" Rd U-bolt			
	1	081401	Steering Arm			
	1	121000	Transfer Case Drop Kit			
	2	55650	Front 5500 Shock			
	2	55639	Rear 5500 Shock			
8" Front / 8" Rear Front Leaf Springs	2	001801	Front Spring	Page 128	Steering Stabilizers	1
Rear Leaf Springs	1	011003	Front Box Kit	55660	Front 5500 Auxiliary Shock (2 req'd)	2
1/2 Ton vehicle only	2	001809	Rear Spring 52" Eye to Eye	081402	2" Adjustable Drag Link	3
Kit #147H 45CK7041	1	011009	Rear Box Kit	121001	GM Frame Support Kit	4
	1	081401	Steering Arm	121005	Front Spring Eye Bolts	5
	1	082501	3" Steering Block	121009	Rear Spring Eye Bolts	6
	1	121000	Transfer Case Drop Kit	98224650	FOX 2.0 Front Gas Shock (2 req'd)	
	1	121632	Front Anti-Sway Bar Links	98224639	FOX 2.0 Rear Gas Shock (2 req'd)	
	2	55650	Front 5500 Shock	98224660	FOX 2.0 Front Gas Aux. Shock (2 req'd)	
	2	55639	Rear 5500 Shock			
8" Front / 8" Rear Front Leaf Springs	2	001801	Front Spring			
Rear Leaf Springs	1	011003	Front Box Kit			
2" Block Kit	2	001608	Rear Spring 56" Eye to Eye			
3/4 Ton vehicle only	1	011208	Rear 2" Box Kit			
Kit #148H 06CK1841	1	081401	Steering Arm			
	1	082501	3" Steering Block			
	1	121000	Transfer Case Drop Kit			
	1	121632	Front Anti-Sway Bar Links			
	2	55650	Front 5500 Shock			
	2	55639	Rear 5500 Shock			



#121632



#121001
GM Frame Support

Notes

1. Both driveshafts may need to be lengthened.
2. Aftermarket extended brake lines required for installation.
3. Exhaust modification may be required to clear front driveshaft.
4. Emergency brake cable extension kit may be required.
5. #001408 and #001608 come with OE style rubber bushings installed.
6. For rear spring applications, you must measure the eye to eye dimension of the original springs before ordering lifted springs. Not all 3/4 ton rear springs are 56". Not all 1/2 ton rear springs are 52".

1977-1987 CHEVROLET 1500 & 2500 TRUCK, BLAZER & SUBURBAN 4WD / GMC JIMMY 4WD GLIDE-RIDE SYSTEM

CHEVROLET/
GMC

1977-1987 CHEVY/GMC 1500 & 2500 TRUCK 4WD • 1977-1987 CHEVY BLAZER, SUBURBAN 4WD / GMC JIMMY 4WD

Lift & Method	Qty	Part#	Description	Recommended Accessories	Notes
2.5" Front / 2" Rear Front Leaf Springs Rear Blocks 1/2 Ton Kit #121H 3/4 Ton Kit #122H 85CK216	2 1 1 1 2 2	001201 011001 011209 011208 55620 55629	Front Spring Front Box Kit 1/2 Ton Rear 2" Box Kit or 3/4 Ton Rear 2" Box Kit Front 5500 Shock Rear 5500 Shock	Page 128 55620 121001 121004 121009 98224620 98224629 98224620	Steering Stabilizers Front 5500 Auxiliary Shock (2 req'd) GM Frame Support Kit Front Spring Eye Bolts Rear Spring Eye Bolts FOX 2.0 Front Gas Shock (2 req'd) FOX 2.0 Rear Gas Shock (2 req'd) FOX 2.0 Front Gas Aux. Shock (2 req'd)
4" Front / 4" Rear Front Leaf Springs Rear Blocks 1/2 Ton Kit #123H 3/4 Ton Kit #124H 58CK247	2 1 1 1 1 2 2	001401 011001 011409 011408 081401 55620 55639	Front Spring Front Box Kit 1/2 Ton Rear 4" Box Kit or 3/4 Ton Rear 4" Box Kit Steering Arm Front 5500 Shock Rear 5500 Shock	Page 128 55650 081402 121000 121001 119158 121004 121009	Steering Stabilizers Front 5500 Auxiliary Shock (2 req'd) 2" Adjustable Drag Link Transfer Case Drop GM Frame Support Kit Short Add-a-leaf (use in place of 119157) Front Spring Eye Bolts Rear Spring Eye Bolts
4" Front / 4" Rear Front Leaf Springs Rear Blocks and Add-A-Leafs 1/2 Ton Kit #125H 3/4 Ton Kit #126H 30CK018	2 1 1 1 1 2 2	001401 011001 119157 011209 011208 081401 55620 55639	Front Spring Front Box Kit Long Rear Add-a-leaf 1/2 Ton Rear 2" Box Kit or 3/4 Ton Rear 2" Box Kit Steering Arm Front 5500 Shock Rear 5500 Shock	98224620 98224639 98224650 121632	FOX 2.0 Front Gas Shock (2 req'd) FOX 2.0 Rear Gas Shock (2 req'd) FOX 2.0 Front Gas Aux. Shock (2 req'd) Front Anti-Sway Bar Link
4" Front / 4" Rear Front Leaf Springs Rear Leaf Springs 1/2 Ton Vehicle Only Kit #127H 13CK9611	2 1 2 1 1 2 2	001401 011001 001409 011009 081401 55620 55639	Front Spring Front Box Kit Rear Spring 52" Eye to Eye Rear Box Kit Steering Arm Front 5500 Shock Rear 5500 Shock		3 5 6 7
4" Front / 4" Rear Front Leaf Springs Rear Leaf Springs 3/4 Ton Vehicle Only Kit #128H 65CK1711	2 1 2 4 1 2 2	001401 011001 001408 4032 081401 55620 55639	Front Spring Front Box Kit Rear Spring 56" Eye to Eye 5/8 x 3-5/8 x 10" Rd U-bolts Steering Arm Front 5500 Shock Rear 5500 Shock		
6" Front / 6" Rear Front Leaf Springs Rear Blocks and Add-A-Leafs 1/2 Ton Kit #129H 3/4 Ton Kit #130H 80CK939	2 1 1 1 1 2 2	001551 011001 119157 011409 011408 081401 121000 55650 55639	Front Spring Front Box Kit Long Rear Add-a-leaf 1/2 Ton Rear 4" Box Kit or 3/4 Ton Rear 4" Box Kit Steering Arm Transfer Case Drop Kit Front 5500 Shock Rear 5500 Shock	Page 128 55650 081402 121001 121632 119158 121004 121009	Steering Stabilizers Front 5500 Auxiliary Shock (2 req'd) 2" Adjustable Drag Link GM Frame Support Kit Front Anti-Sway Bar Links Short Add-a-leaf (use in place of 119157) Front Spring Eye Bolts Rear Spring Eye Bolts
6" Front / 6" Rear Front Leaf Springs Rear Leaf Springs 1/2 Ton Vehicle Only Kit #131H 80CK3921	2 1 2 2 1 1 1 2 2	001551 011001 001609 011009 081401 121000 55650 55639	Front Spring Front Box Kit Rear Spring 52" Eye to Eye Rear Box Kit Steering Arm Transfer Case Drop Kit Front 5500 Shock Rear 5500 Shock	98224650 98224639 98224660	FOX 2.0 Front Gas Shock (2 req'd) FOX 2.0 Rear Gas Shock (2 req'd) FOX 2.0 Front Gas Aux. Shock (2 req'd)
6" Front / 6" Rear Front Leaf Springs Rear Leaf Springs 3/4 Ton Vehicle Only Kit #132H 12CK5231	2 1 2 4 1 1 2 2	001551 011001 001608 4032 081401 121000 55650 55639	Front Spring Front Box Kit Rear Spring 56" Eye to Eye 5/8 x 3-5/8 x 10" Rd U-bolts Steering Arm Transfer Case Drop Kit Front 5500 Shock Rear 5500 Shock		



See Notes ▶

Vehicle Specs:
8" Lift Kit
35x14 Bagger
16x12 M/T Classic II

Continued ▶

DODGE

FORD

JEEP

SUZUKI

TOYOTA

POSI-LOK

SHOCKS/
STEERING
STABILIZERS

APPAREL/
PROMOTIONAL

PRODUCT
SPECS

VEHICLE
SPECS

'77-'87 CHEVY/GMC 1500 & 2500 TRUCK 4WD • '77-'87 CHEVY BLAZER & SUBURBAN 4WD / GMC JIMMY 4WD (CONT'D)

Lift & Method	Qty	Part#	Description	Recommended Accessories	Notes	
8" Front / 8" Rear Front Leaf Springs Rear Leaf Springs 1/2 Ton Vehicle Only Kit #133H 02CK2931	2	001801	Front Spring	Page 128	1	
	1	011001	Front Box Kit	55660	2	
	2	001809	Rear Spring 52" Eye to Eye	121001	3	
	1	011009	Rear Box Kit	081402	4	
	1	081401	Steering Arm	121004	5	
	1	082501	3" Steering Block	121009	6	
	1	121000	Transfer Case Drop Kit	98224650		
	1	121632	Anti-Sway Bar Links	98224639		
	2	55650	Front 5500 Shock	98224660		
	2	55639	Rear 5500 Shock			
	8" Front / 8" Rear Front Leaf Springs Rear Leaf Springs & 2" Block Kit 3/4 Ton Vehicle Only Kit #134H 62CK6641	2	001801	Front Spring		
		1	011001	Front Box Kit		
2		001608	Rear 6" Spring 56" Eye to Eye			
1		011208	Rear 2" Box Kit			
1		081401	Steering Arm			
1		082501	3" Steering Block			
1		121000	Transfer Case Drop Kit			
1		121632	Anti-Sway Bar Links			
2		55650	Front 5500 Shock			
2		55639	Rear 5500 Shock			



Vehicle Specs:
8" Lift Kit
37" Toyo M/T
18x9 ARE Cannon



- Notes**
- Both driveshafts may need to be lengthened.
 - Aftermarket extended brake lines required for installation.
 - Exhaust modification may be required to clear front driveshaft.
 - Emergency brake cable extension kit may be required.
 - #001408 and #001608 come with OE style rubber bushings installed.
 - For rear spring applications, you must measure the eye to eye dimension of the original springs before ordering lifted springs. Not all 3/4 ton rear springs are 56". Not all 1/2 ton rear springs are 52".
 - 121632 Required to retain factory sway bar. No relocation included in kits.

1973-1976 CHEVY/GMC 1500 & 2500 TRUCK / CHEVY BLAZER & SUBURBAN 4WD / GMC JIMMY 4WD GLIDE-RIDE SYSTEM

1973-1976 CHEVROLET/GMC 1500 & 2500 4WD TRUCK / CHEVY BLAZER & SUBURBAN 4WD / GMC JIMMY 4WD

Lift & Method	Qty	Part#	Description	Recommended Accessories	Notes
2.5" Front / 2" Rear Front Leaf Springs Rear Blocks 1/2 Ton Kit #107H 3/4 Ton Kit #108H 85CK216	2	001201	Front Spring	Page 128	
	1	011002	Front Box Kit	121001	
	1	011209	1/2 Ton Rear 2" Box Kit or	121004	
	1	011208	3/4 Ton Rear 2" Box Kit	121009	
	2	55620	Front 5500 Shock	98224620	
	2	55629	Rear 5500 Shock	98224629	
4" Front / 4" Rear Front Leaf Springs Rear Blocks 1/2 Ton Kit #109H 3/4 Ton Kit #110H 58CK247	2	001401	Front Spring	Page 128	1
	1	011002	Front Box Kit	081402	2
	1	011409	1/2 Ton Rear 4" Box Kit or	121000	
	1	011408	3/4 Ton Rear 4" Box Kit	121001	
	1	081401	Steering Arm	119158	
	2	55620	Front 5500 Shock		
4" Front / 4" Rear Front Leaf Springs Rear Blocks and Add-A-Leafs 1/2 Ton Kit #111H 3/4 Ton Kit #112H 30CK018	2	001401	Front Spring	121004	
	1	011002	Front Box Kit	121009	
	1	119157	Long Rear Add-a-leaf	121003	
	1	011209	1/2 Ton Rear 2" Box Kit or	98224620	
	1	011208	3/4 Ton Rear 2" Box Kit	98224639	
	2	081401	Steering Arm		
2	55620	Front 5500 Shock			
2	55639	Rear 5500 Shock			

- Notes**
- #001408 and #001608 come with OE style rubber bushings installed.
 - For rear spring applications, you must measure the eye to eye dimension of the original springs before ordering lifted springs. Not all 3/4 ton rear springs are 56". Not all 1/2 ton rear springs are 52".

Continued ▶

1973-1976 CHEVY/GMC 1500 & 2500 TRUCK / CHEVY/GMC BLAZER, JIMMY, & SUBURBAN 4WD *GLIDE-RIDE SYSTEM*

CHEVROLET/
GMC

1973-1976 CHEVROLET/GMC 1500 & 2500 TRUCK 4WD / CHEVY BLAZER & SUBURBAN 4WD / GMC JIMMY 4WD (CONT'D)

Lift & Method	Qty	Part#	Description	Recommended Accessories	Notes	
4" Front / 4" Rear Front Leaf Springs Rear Leaf Springs <i>1/2 Ton Vehicle Only</i> Kit #113H 13CK9611	2 1 2 1 1 2 2	001401 011002 001409 011009 081401 55620 55639	Front Spring Front Box Kit Rear Spring 52" Eye to Eye Rear Box Kit Steering Arm Front 5500 Shock Rear 5500 Shock	Page 128 081402 121000 121001 121004 121009 121003	Steering Stabilizers 2" Adjustable Drag Link Transfer Case Drop GM Frame Support Kit Front Spring Eye Bolts Rear Spring Eye Bolts Front Anti-Sway Bar Drop Kit	5 6
4" Front / 4" Rear Front Leaf Springs Rear Leaf Springs <i>3/4 Ton Vehicle Only</i> Kit #114H 65CK1711	2 1 2 4 1 2 2	001401 011002 001408 4032 081401 55620 55639	Front Spring Front Box Kit Rear Spring 56" Eye to Eye 5/8 x 3-5/8 x 10" Rd U-bolts Steering Arm Front 5500 Shock Rear 5500 Shock	98224620 98224639	FOX 2.0 Front Gas Shock (2 req'd) FOX 2.0 Rear Gas Shock (2 req'd)	
6" Front / 6" Rear Front Leaf Springs Rear Blocks and Add-A-Leafs <i>1/2 Ton Kit #115H</i> <i>3/4 Ton Kit #116H</i> 80CK939	2 1 1 1 1 1 2 2	001551 011002 119157 011409 011408 081401 121000 55650 55639	Front Spring Front Box Kit Long Rear Add-a-leaf 1/2 Ton Rear 4" Box Kit <i>or</i> 3/4 Ton Rear 4" Box Kit Steering Arm Transfer Case Drop Kit Front 5500 Shock Rear 5500 Shock	Page 128 081402 121001 121632 119158 121004 121009	Steering Stabilizers 2" Adjustable Drag Link GM Frame Support Kit Front Anti-Sway Bar Links Short Rear Add-a-leaf (use in place of 119157) Front Spring Eye Bolts Rear Spring Eye Bolts	3 5 6
6" Front / 6" Rear Front Leaf Springs Rear Leaf Springs <i>1/2 Ton Vehicle Only</i> Kit #117H 80CK3921	2 1 2 1 1 1 2 2	001551 011002 001609 011009 081401 121000 55650 55639	Front Spring Front Box Kit Rear Springs 52" Eye to Eye Rear Box Kit Steering Arm Transfer Case Drop Front 5500 Shock Rear 5500 Shock	98224650 98224639	FOX 2.0 Front Gas Shock (2 req'd) FOX 2.0 Rear Gas Shock (2 req'd)	
6" Front / 6" Rear Front Leaf Springs Rear Leaf Springs <i>3/4 Ton Vehicle Only</i> Kit #118H 12CK5231	2 1 2 4 1 1 2 2	001551 011002 001608 4032 081401 121000 55650 55639	Front Spring Front Box Kit Rear Spring 56" Eye to Eye 5/8 x 3-5/8 x 10" Rd U-bolts Steering Arm Transfer Case Drop Kit Front 5500 Shock Rear 5500 Shock			
8" Front / 8" Rear Front Leaf Springs Rear Leaf Springs <i>1/2 Ton Vehicle Only</i> Kit #119H 02CK2931	2 1 2 2 1 1 1 1 1 2 2	001801 011002 001809 011009 081401 082501 121000 121632 55650 55639	Front Spring Front Box Kit Rear Spring 52" Eye to Eye Rear Box Kit Steering Arm 3" Steering Block Transfer Case Drop Kit Anti-Sway Bar Links Front 5500 Shock Rear 5500 Shock	Page 128 081402 121001 121004 121009 98224650 98224639	Steering Stabilizers 2" Adjustable Drag Link GM Frame Support Brackets Front Spring Eye Bolts Rear Spring Eye Bolts FOX 2.0 Front Gas Shock (2 req'd) FOX 2.0 Rear Gas Shock (2 req'd)	1 2 3 4 5 6
8" Front / 8" Rear Front Leaf Springs Rear Leaf Springs & 2" Block Kit <i>3/4 Ton Vehicle Only</i> Kit #120H 62CK6641	2 1 2 1 1 1 1 1 1 2 2	001801 011002 001608 011208 081401 082501 121000 121632 55650 55639	Front Spring Front Box Kit Rear 6" Spring 56" Eye to Eye Rear 2" Box Kit Steering Arm 3" Steering Block Transfer Case Drop Kit Anti-Sway Bar Links Front 5500 Shock Rear 5500 Shock			



Notes

- Both driveshafts may need to be lengthened.
- Aftermarket extended brake lines required for installation.
- Exhaust modification may be required to clear front driveshaft.
- Emergency brake cable extension kit may be required.
- #001408 and #001608 come with OE style rubber bushings installed.
- For rear spring applications, you must measure the eye to eye dimension of the original springs before ordering lifted springs. Not all 3/4 ton rear springs are 56". Not all 1/2 ton rear springs are 52".



Vehicle Specs:
8" Lift Kit
38" Beggars
16" Steel Wheels

DODGE

FORD

JEEP

SUZUKI

TOYOTA

POSI-LOK

SHOCKS/
STEERING
STABILIZERS

APPAREL/
PROMOTIONAL

PRODUCT
SPECS

VEHICLE
SPECS

1969-1972 CHEVROLET BLAZER 4WD / GMC JIMMY 4WD

GLIDE-RIDE SYSTEM

DODGE

FORD

JEEP

SUZUKI

TOYOTA

POSI-LOK

SHOCKS/
STEERING
STABILIZERS

APPAREL/
PROMOTIONAL

PRODUCT
SPECS

VEHICLE
SPECS

1969-1972 CHEVROLET BLAZER 4WD / GMC JIMMY 4WD

Lift & Method	Qty	Part#	Description	Recommended Accessories	Notes
4" Front / 4" Rear	2	001402	Front Spring	Page 128	1
Front Leaf Springs	1	011002	Front Box Kit	081402	
Rear Blocks	1	011407	Rear Box Kit	121000	
Kit #104H	1	081401	Steering Arm	119158	
<i>16CK647</i>	2	55620	Front 5500 Shock		
	2	55660	Rear 5500 Shock		
4" Front / 4" Rear	2	001402	Front Spring	121004	
Front Leaf Springs	1	011002	Front Box Kit	121009	
Rear Blocks and	1	119157	Long Rear Add-a-leaf	121003	
Add-A-Leafs	1	011307	1/2 ton Rear 3" Box Kit	98224620	
Kit #105H	1	081401	Steering Arm	98224660	
<i>47CK128</i>	2	55620	Front 5500 Shock		
	2	55660	Rear 5500 Shock		
4" Front / 4" Rear	2	001402	Front Spring		
Front Leaf Springs	1	011002	Front Box Kit		
Rear Leaf Springs	2	001609	Rear Spring 52" Eye to Eye		
1/2 Ton Vehicle Only	1	011007	Rear Box Kit		
Kit #106H	1	081401	Steering Arm		
<i>40CK7711</i>	2	55620	Front 5500 Shock		
	2	55660	Rear 5500 Shock		



Notes

1. Vehicle must have 3-bolt steering knuckle.

Vehicle Specs:
4" Lift Kit
35" BFG M/T
15" Steel Wheels

CHEVROLET/GMC K10/K15 & K20/K25 TRUCK

GLIDE-RIDE SYSTEM

1969-1972 CHEVROLET/GMC K10/K15 (1/2-TON) TRUCK 4WD & K20/K25 (3/4-TON) TRUCK 4WD

Lift & Method	Qty	Part#	Description	Recommended Accessories	Notes
4" Front / 4" Rear	2	001402	Front Spring	Page 128	1 2
Front Leaf Springs	1	011002	Front Box Kit	081402	
Rear Blocks	1	011407	Rear 4" Box Kit	121000	
Kit #100H	1	081401	Steering Arm	119158	
<i>16CK647</i>	2	55620	Front 5500 Shock		
	2	55660	Rear 5500 Shock		
4" Front / 4" Rear	2	001402	Front Spring	121004	
Front Leaf Springs	1	011002	Front Box Kit	121009	
Rear Blocks and	1	119157	Long Rear Add-a-leaf	121003	
Add-A-Leafs	1	011307	1/2 Ton Rear 3" Box Kit	98224620	
Kit #101H	1	081401	Steering Arm	98224660	
<i>47CK128</i>	2	55620	Front 5500 Shock		
	2	55660	Rear 5500 Shock		
4" Front / 4" Rear	2	001402	Front Spring		
Front Leaf Springs	1	011002	Front Box Kit		
Rear Leaf Springs	2	001409	Rear Spring 52" Eye to Eye		
1/2 Ton Vehicle Only	1	011007	Rear Box Kit		
Kit #102H	1	081401	Steering Arm		
<i>47CK2711</i>	2	55620	Front 5500 Shock		
	2	55660	Rear 5500 Shock		
4" Front / 4" Rear	2	001402	Front Spring		
Front Leaf Springs	1	011002	Front Box Kit		
Rear Leaf Springs	2	001408	Rear Spring 56" Eye to Eye		
3/4 Ton Vehicle Only	4	4036	9/16 x 2-1/2 x 8-3/4" Sq U-bolts		
Kit #103H	1	081401	Steering Arm		
<i>69CK9611</i>	2	55620	Front 5500 Shock		
	2	55660	Rear 5500 Shock		



Vehicle Specs:
4" Lift Kit
35" BFG A/T
15" Steel Wheels



Notes

1. #001408 and #001608 come with OE style rubber bushings installed.
2. For rear spring applications, you must measure the eye to eye dimension of the original springs before ordering lifted springs. Not all 3/4 ton rear springs are 56". Not all 1/2 ton rear springs are 52".

DODGE



2009-2014 DODGE RAM 1500 4WD TRUCK IFS SYSTEM



*Coil-Over kit shown, standard kit utilizes strut spacers and BDS-5500 rear shocks

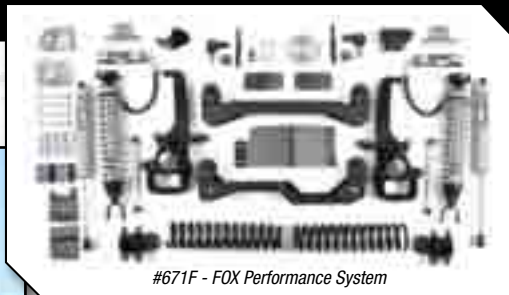

#671F - FOX Performance System

4" & 6" Kit Features

- 1/4" Laser cut crossmembers with high clearance design
- Differential skid plate included
- Front Kevlar lined stainless steel brake lines
- Upper strut spacer included for factory ride
- Improved geometry
- Rear Pro-Ride coil springs or coil spacers



2013-2014 DODGE RAM 1500 4WD TRUCK

Lift & Method	Qty	Part#	Description	Recommended Accessories	Notes
4" Front / 2" Rear IFS System (Strut Spacer) Rear Coil Spacer Kit# 670H 91DK2202	1	022630	Front Box Kit 1 of 4	98224758	1 2 3 4 6
	1	022631	Front Box Kit 2 of 4	022309	
	1	022402	Front Box Kit 3 of 4		
	1	022625	Front Box Kit 4 of 4	FOX 2.0 Rear Gas Shock (2 req'd)	
	1	022209	Rear 2" Box Kit	Rear 3" Coil Box Kit	
	2	55758	Rear 5500 Shock		
6" Front / 3" Rear IFS System (Strut Spacer) Rear Coil Kit# 671H 90DK6122 Fox Performance System Kit# 671F 90DK5893	1	022630	Front Box Kit 1 of 4	98224758	1 2 3 4 5 6
	1	022631	Front Box Kit 2 of 4	022509	
	1	022624	Front Box Kit 3 of 4	FOX 2.0 Rear Gas Shock (2 req'd)	
	1	022625	Front Box Kit 4 of 4	Rear 5" Coil Box Kit	
	1	022309	Rear 3" Box Kit		
	2	55758	Rear 5500 Shock or		
2	98224758	FOX 2.0 Rear Gas Shock			

ATTENTION: MEASURE YOUR TRUCK FIRST!
Tail height on '09-14 Rams will vary from 1"-3" from the factory. Use #022209 (2"), #022309 (3"), or #022509 (5") rear box kit to achieve desired stance.

2012 DODGE RAM 1500 4WD TRUCK

Lift & Method	Qty	Part#	Description	Recommended Accessories	Notes
4" Front / 2" Rear IFS System (Strut Spacer) Rear Coil Spacer Kit# 664H 91DK2202	1	022620	Front Box Kit 1 of 4	55311	1 2 3 4
	1	022621	Front Box Kit 2 of 4	55419	
	1	022402	Front Box Kit 3 of 4	98224758	
	1	022625	Front Box Kit 4 of 4	FOX 2.0 Rear Gas Shock (2 req'd)	
	1	022209	Rear 2" Box Kit	022309	
	2	55758	Rear Shock	Rear 3" Coil Box Kit	
6" Front / 3" Rear IFS System (Strut Spacer) Rear Coil Kit# 663H 90DK6122 Fox Performance System Kit# 663F 90DK5893	1	022620	Front Box Kit 1 of 4	55311	1 2 3 4 5
	1	022621	Front Box Kit 2 of 4	55419	
	1	022624	Front Box Kit 3 of 4	98224758	
	1	022625	Front Box Kit 4 of 4	FOX 2.0 Rear Gas Shock (2 req'd)	
	1	022309	Rear 3" Box Kit	022509	
	2	55758	Rear 5500 Shock or		
2	98224758	FOX 2.0 Rear Gas Shock			

2009-2011 DODGE RAM 1500 4WD TRUCK

Lift & Method	Qty	Part#	Description	Recommended Accessories	Notes
4" Front / 3" Rear IFS System (Strut Spacer) Rear Coil Kit# 623H 10DK5922	1	022620	Front Box Kit 1 of 4	55311	1 2 3 4
	1	022621	Front Box Kit 2 of 4	55419	
	1	022401	Front Box Kit 3 of 4	98224758	
	1	022605	Front Box Kit 4 of 4	FOX 2.0 Rear Gas Shock (2 req'd)	
	1	022309	Rear Box Kit		
	2	55758	Rear 5500 Shock		
6" Front / 5" Rear IFS System (Strut Spacer) Rear Coil Kit# 622H 74DK0042 Fox Performance System Kit# 622F 74DK9614	1	022620	Front Box Kit 1 of 4	55311	1 2 3 4 5
	1	022621	Front Box Kit 2 of 4	55419	
	1	022623	Front Box Kit 3 of 4	98224759	
	1	022605	Front Box Kit 4 of 4	FOX 2.0 Rear Gas Shock (2 req'd)	
	1	022509	Rear Box Kit	022309	
	2	55759	Rear 5500 Shock or		
2	98224759	FOX 2.0 Rear Gas Shock			

Notes

1. Be sure to measure your vehicle before ordering. Tail height on these trucks vary from 1"-3" from the factory. The 022209, 022309, and 022509 can all be substituted to achieve the desired stance.
2. Rack & Pinion steering system is extremely sensitive to any out of round or out of balance tire/wheel combination. The larger the tire the less the backspacing, the more sensitive the system, causing minor steering wheel shimmy.
3. Not recommended for AWD models.
4. Stock 17" and 18" wheels can not be re-installed. Stock 20" can be reinstalled with factory tire.
5. TRX models will achieve approximately 1" of additional lift. This lift is not recommended for use on the TRX models due to possible CV shaft vibration caused by the additional lift. Instead, consider our 4" lift system for 5" of lift or replace the TRX struts with standard struts for use with this system.
6. Will not fit adjustable air suspension equipped models.

2006-2008 DODGE RAM 1500 4WD TRUCK

IFS SYSTEM

CHEVROLET/
GMC

DODGE

FORD

JEEP

SUZUKI

TOYOTA

POSI-LOK

SHOCKS/
STEERING
STABILIZERS

APPAREL/
PROMOTIONAL

PRODUCT
SPECS

VEHICLE
SPECS



#624H - 6" Standard IFS Kit

6" Kit Features

- 1/4" Laser cut crossmembers with high clearance design
- Differential skid plate included for offroad protection
- 3-Point differential drop for proper drive line angles
- Replacement steering knuckles included for easy installation
- Front Kevlar lined stainless steel brake lines included
- Upper strut spacer included to maintain factory ride quality
- Choice of rear block or replacement leaf springs



2" Front Strut Spacer Kit
(top & preload spacers)

2006-2008 DODGE RAM 1500 4WD TRUCK

Lift & Method	Qty	Part#	Description	Recommended Accessories	Notes
2" Front / 0" Rear Front Strut Spacer Kit Kit# #261H 45DK431	1	012202	Front Spacer Kit	55719 Rear 5500 Shock (2 req'd) 98224719 FOX 2.0 Rear Gas Shock (2 req'd)	1
4" Front / 2" Rear IFS System (strut spacer) Block Kit Kit# 625H 26DK2181	1 1 1 1 2	022620 022621 022401 022605 012218 55758	Front Box Kit 1 of 4 Front Box Kit 2 of 4 Front Box Kit 3 of 4 Front Box Kit 4 of 4 Rear Box Kit Rear 5500 Shock	55311 Dual Steering Stabilizer Mount 55419 Dual Steering Stabilizer Shock (2 req'd) 122617 Rear Traction Bars 98224758 FOX 2.0 Rear Gas Shock (2 req'd)	1 2 3 4 5
6" Front / 4" Rear IFS System (strut spacer) Block Kit Kit# 624H 44DK3191 Kit# 624F 44DK2863	1 1 1 1 1 1 2 2	022620 022621 022623 022605 012418 88302073 55769 98224769	Front Box Kit 1 of 4 Front Box Kit 2 of 4 Front Box Kit 3 of 4 Front Box Kit 4 of 4 Rear Box Kit FOX 2.5 Coilover Kit Rear 5500 Shock or FOX 2.0 Rear Gas Shock	55311 Dual Steering Stabilizer Mount 55419 Dual Steering Stabilizer Shock (2 req'd) 98224769 FOX 2.0 Gas Shock (2 req'd) 122617 Rear Traction Bars	1 2 3 4 5
6" Front / 4" Rear IFS System (strut spacer) Leaf Springs Kit# 626H 04DK1172 Fox Performance System Kit# 626F 04DK0844	1 1 1 1 2 1 2 2	022620 022621 022623 022605 002506 012519 88302073 55769 98224769	Front Box Kit 1 of 4 Front Box Kit 2 of 4 Front Box Kit 3 of 4 Front Box Kit 4 of 4 Rear Leaf Spring Rear Box Kit FOX 2.5 Coilover Kit Rear 5500 Shock or FOX 2.0 Rear Gas Shock	55311 Dual Steering Stabilizer Mount 55419 Dual Steering Stabilizer Shock (2 req'd) 98224769 FOX 2.0 Gas Shock (2 req'd) 122617 Rear Traction Bars	1 2 3 4 5

Notes

1. Will not fit Mega-Cab models.
2. Rack & Pinion steering system is extremely sensitive to any out of round or out of balance tire/wheel combination. The larger the tire the less the backspacing, the more sensitive the system, causing minor steering wheel shimmy.
3. Not recommended for AWD models.
4. TRX models require removal of OE lower skid plate.
5. Stock 17"-18" wheels can not be re-installed. Stock 20" wheels can be re-installed with stock tires.

FOX PERFORMANCE
COILOVER SYSTEM

#88302073



Vehicle Specs:
6" Lift Kit
35" Nitto M/T
20" Moto Metal 951

2002-2005 DODGE RAM 1500 4WD TRUCK

IFS SYSTEM

DODGE

FORD

JEEP

SUZUKI

TOYOTA

POSI-LOK

SHOCKS/
STEERING
STABILIZERS

APPAREL/
PROMOTIONAL

PRODUCT
SPECS

VEHICLE
SPECS



4" & 6" Kit Features

- No Torsion Bar Drop System
- One piece front and rear crossmembers increase frame rigidity while reducing installation time
- Steering knuckle included to reduce installation time
- High clearance crossmembers, differential skid plate, and compression struts included for off road use
- Front and rear bump stop extensions included
- Allows use of stock wheels with stock tires



Vehicle Specs:
6" Lift Kit
35" Nitto M/T
20" AR Cannon



2002-2005 DODGE RAM 1500 4WD TRUCK

Lift & Method	Qty	Part#	Description	Recommended Accessories	Notes	
4" Front / 2" Rear	1	022610	Box Kit 1 of 4	122619	Traction Bars	1
	1	022611	Box Kit 2 of 4	122009	Rear Dual Shock Bracket Kit	2
	1	022410	Box Kit 3 of 4	55758	Dual 5500 Shock (2 req'd)	3
	1	022411	Box Kit 4 of 4	55311	Dual Steering Stabilizer Mounting	4
	1	012218	Rear Block Kit	55419	Dual Steering Stabilizer Shocks (2 req'd)	5
	2	55711	Front Shock			6
6" Front / 4" Rear	2	55758	Rear Shock			
	1	022610	Box Kit 1 of 4	122619	Traction Bars	1
	1	022611	Box Kit 2 of 4	122009	Rear Dual Shock Bracket Kit	2
	1	022612	Box Kit 3 of 4	55769	Dual 5500 Shocks (2 req'd)	3
	1	022613	Box Kit 4 of 4	55311	Dual Steering Stabilizer Mount	4
	1	012419	Rear Block Kit	55419	Dual Steering Stabilizer Shock (2 req'd)	5
6" Front / 4" Rear	2	55711	Front Shock			6
	2	55769	Rear Shock			
	1	022610	Box Kit 1 of 4			
	1	022611	Box Kit 2 of 4			
	1	022612	Box Kit 3 of 4			
	1	022613	Box Kit 4 of 4			
	2	002506	Rear Leaf Spring			
	4	4054	9/16 x 3-1/2 x 9-1/2" U-bolt			
2	55711	Front Shock				
2	55769	Rear Shock				

ACCESSORIES



Notes:

1. Rack & Pinion steering system is extremely sensitive to any out of round or out of balance tire/wheel combination. The larger the tire and the less the backspring, the more sensitive the system, causing minor steering wheel shimmy.
2. Stock 17" wheels can not be reinstalled. Stock 20" wheels w/stock tires can be used.
3. Special tool required to load/unload torsion bars and puller required to remove lower control arm bushings.
4. Depending on cab configuration, these vehicles vary from 1" to over 4" tall high from the factory. Be sure to measure the vehicle before deciding how much to lift the rear.
5. May require exhaust modification to clear front drive shaft, typically on std cab models.
6. AWD models may require a CV style front drive shaft.

2001 DODGE RAM 1500 4WD TRUCK

PRO-RIDE SYSTEM

CHEVROLET/
GMC

DODGE

FORD

JEEP

SUZUKI

TOYOTA

POSI-LOK

SHOCKS/
STEERING
STABILIZERS

APPAREL/
PROMOTIONAL

PRODUCT
SPECS

VEHICLE
SPECS



'94-'01 Dodge 1500 Long Arm Upgrade Kit '94-'02 Dodge 2500 Long Arm Upgrade Kit

- Upgrade your existing 5" kit to a long arm
- Fits all Dodge '94-01 1/2 Ton & '94-'02 3/4 Ton 4WD with 5"-6" of lift
- Kit includes longer lower links—greaseable, frame mount brackets, lower arm bushing/sleeve kit

#122505.....37DK294

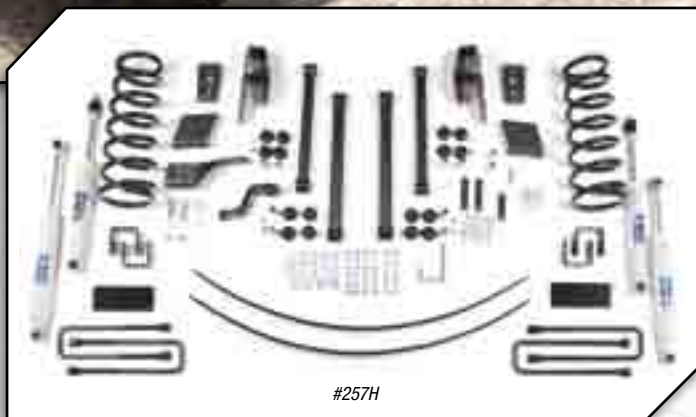

#257H

3" Pro-Ride Suspension System for Offroad Package or
5" Pro-Ride Suspension System for Standard truck

2001 DODGE RAM 1500 4WD TRUCK WITH OFFROAD PACKAGE

Lift & Method	Qty	Part#	Description	Recommended Accessories	Notes
3" Front / 3" Rear Standard Kit	1	012301	Front Spacer Kit	98224700 FOX 2.0 Front Gas Shock (2 req'd)	1
	1	012504	Front Box Kit	98224759 FOX 2.0 Rear Gas Shock (2 req'd)	2
	1	012308	Rear Kit	122301 Front Dual Shock Box Kit	
	1	55406	Single Steering Stabilizer	55650 Dual 5500 Shock (2 req'd) or	
	1	55700	Front 5500 Shock	98224650 FOX 2.0 Dual Gas Shock (2 req'd)	
Kit #255H 78DK0831	2	55700	Front 5500 Shock	PSL400 4x4 Posi-Lok™ (page 119)	
	2	55759	Rear 5500 Shock	55351 Dual Stabilizer Bracket Kit	
	1	012301	Front Spacer Kit	55404 Dual Steering Stabilizer (2 req'd)	
	1	012511	Long Arm Kit - box 1 of 2		
	1	012512	Long Arm Kit - box 2 of 2		
3" Front / 3" Rear Long Arm Kit	1	012308	Rear Kit		
	1	55406	Single Steering Stabilizer		
	1	55700	Front 5500 Shock		
	2	55759	Rear 5500 Shock		
	1	032501	Front Coil Springs		
3" Front / 3" Rear Standard Kit	1	012504	Front Box Kit		
	1	012308	Rear Kit		
	1	55406	Single Steering Stabilizer		
	1	55700	Front 5500 Shock		
	2	55759	Rear 5500 Shock		
Kit #257H 49DK4631	1	032501	Front Coil Springs		
	1	012511	Long Arm Kit - box 1 of 2		
	1	012512	Long Arm Kit - box 2 of 2		
	1	012308	Rear Kit		
	1	55406	Single Steering Stabilizer		
Kit #258H 79DK1171	1	55406	Single Steering Stabilizer		
	2	55700	Front 5500 Shock		
	2	55759	Rear 5500 Shock		
	1	032501	Front Coil Springs		
	1	012511	Long Arm Kit - box 1 of 2		



#122301 - Dual Shock Mounting Kit

Notes

1. Single stabilizer may be replaced with dual.
2. May require exhaust modification.

2000-2001 DODGE RAM 1500 4WD TRUCK

PRO-RIDE SYSTEM

DODGE

FORD

JEEP

SUZUKI

TOYOTA

POSI-LOK

SHOCKS/
STEERING
STABILIZERS

APPAREL/
PROMOTIONAL

PRODUCT
SPECS

VEHICLE
SPECS

5" Kit Features

- 5" Pro-Ride coils
- Front box kit includes: greaseable upper & lower links, upper link relocation brackets, anti-sway bar relocation brackets, new bump stops, track bar relocation bracket & pitman arm
- Basic rear kit including new shackle hanger brackets and optional rear Glide-Ride springs available
- Long Arm Upgrade Kit #122505 is available to convert existing kits to a long arm—see page 35 for details

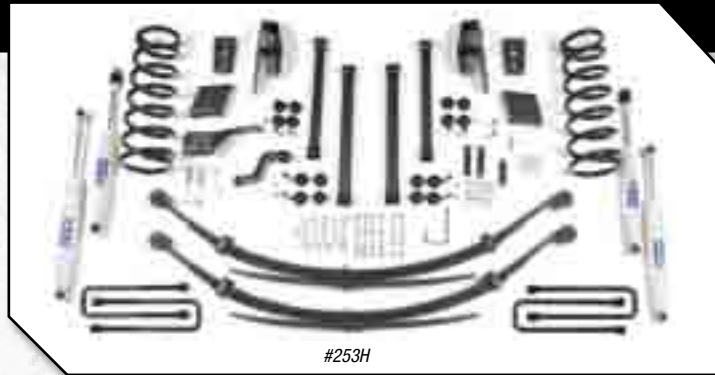

2000-2001 DODGE RAM 1500 4WD TRUCK

Lift & Method	Qty	Part#	Description	Recommended Accessories	Notes
2" Front / 0" Rear Front Coil Spacers Kit #204H 09DK153	1 2 2	012201 55710 55719	Front Spacer Kit Front 5500 Shock Rear 5500 Shock	98224710 98224719 98224700 98224759	FOX 2.0 Front Gas Shock - 2" kit (2 req'd) FOX 2.0 Rear Gas Shock - 2" kit (2 req'd) FOX 2.0 Front Gas Shock - 3" kit (2 req'd) FOX 2.0 Rear Gas Shock - 3" kit (2 req'd)
3" Front / 3" Rear Front Coil Spacers Rear Blocks & Add-A-Leafs Kit #242H 07DK245	1 1 2 2	012301 012309 55700 55759	Front Spacer Kit Rear Kit Front 5500 Shock Rear 5500 Shock	122301 55620 98224620 55406 55351 55404 122305 PSL400	Front Dual Shock Bracket Kit Dual 5500 Shock (2 req'd) or FOX 2.0 Front Gas Shock (2 req'd) Single Steering Stabilizer Dual Steering Stabilizer Bracket Dual Steering Stabilizer (2 req'd) Upper & Lower Control Arm Kit 4x4 Posi-Lok™ (page 119)
5" Front / 5" Rear Standard Kit Front Coils & Brackets Rear Shackle Flip Kit #249H 91DK1341	1 1 1 1 2 2	032501 012504 012509 55406 55750 55761	Front Coil Springs Front Box Kit Rear Shackle Flip Kit Single Steering Stabilizer Front 5500 Shock Rear 5500 Shock	98224750 98224761 122303 55650 98224650 55351 55404 PSL400	FOX 2.0 Front Gas Shock (2 req'd) FOX 2.0 Rear Gas Shock (2 req'd) Front Dual Shock Bracket Kit Dual 5500 Shock (2 req'd) or FOX 2.0 Dual Gas Shock (2 req'd) Dual Steering Stabilizer Bracket Kit Dual Steering Stabilizer (2 req'd) 4x4 Posi-Lok™ (page 119)
5" Front / 5" Rear Long Arm Kit Front Coils & Brackets Rear Shackle Flip Kit #250H 22DK8771	1 1 1 1 2 2	032501 012511 012512 012509 55406 55750 55761	Front Coil Springs Long Arm Kit - box 1 of 2 Long Arm Kit - box 2 of 2 Rear Shackle Flip Kit Single Steering Stabilizer Front 5500 Shock Rear 5500 Shock	55351 55404 PSL400	Dual Steering Stabilizer Bracket Kit Dual Steering Stabilizer (2 req'd) 4x4 Posi-Lok™ (page 119)
5" Front / 4.5" Rear Standard Kit Front Coils & Brackets Rear Blocks & Add-A-Leafs Kit #251H 05DK0431	1 1 1 1 2 2	032501 012504 119158 012307 55406 55750 55761	Front Coil Springs Front Box Kit Rear Add-A-Leaf Rear 3" Block Kit Single Steering Stabilizer Front 5500 Shock Rear 5500 Shock		
5" Front / 4.5" Rear Long Arm Kit Front Coils & Brackets Rear Blocks & Add-A-Leafs Kit #252H 35DK7861	1 1 1 1 1 2 2	032501 012511 012512 119158 012307 55406 55750 55761	Front Coil Springs Long Arm Kit - box 1 of 2 Long Arm Kit - box 2 of 2 Rear Add-A-Leaf Rear 3" Block Kit Single Steering Stabilizer Front 5500 Shock Rear 5500 Shock		
5" Front / 4.5" Rear Standard Kit Front Coils & Brackets Rear Leaf Springs Kit #253H 34DK4261	1 1 2 4	032501 012504 002459 4045	Front Coil Springs Front Box Kit Rear Leaf Spring 9/16 x 2-9/16 x 11-3/8" Rear U-Bolt		
5" Front / 4.5" Rear Long Arm Kit Front Coils & Brackets Rear Leaf Springs Kit #254H 64DK1791	1 1 2 4	032501 012511 012512 002459 4045	Front Coil Springs Long Arm Kit - box 1 of 2 Long Arm Kit - box 2 of 2 Rear Leaf Spring 9/16 x 2-9/16 x 11-3/8" Rear U-Bolt		
	1 2 2	55406 55750 55761	Single Steering Stabilizer Front 5500 Shock Rear 5500 Shock		

ACCESSORIES



Notes

1. The front axle will shift laterally approximately 1/2".
2. The rear axle will be shifted forward in the wheel well.
3. Single stabilizer may be replaced with dual.
4. May require exhaust modification.
5. #002459 rear springs come with OE style bushings installed.

1994-1999 DODGE RAM 1500 4WD TRUCK

PRO-RIDE SYSTEM

CHEVROLET/
GMC

DODGE

FORD

JEEP

SUZUKI

TOYOTA

POSI-LOK

SHOCKS/
STEERING
STABILIZERS

APPAREL/
PROMOTIONAL

PRODUCT
SPECS

VEHICLE
SPECS

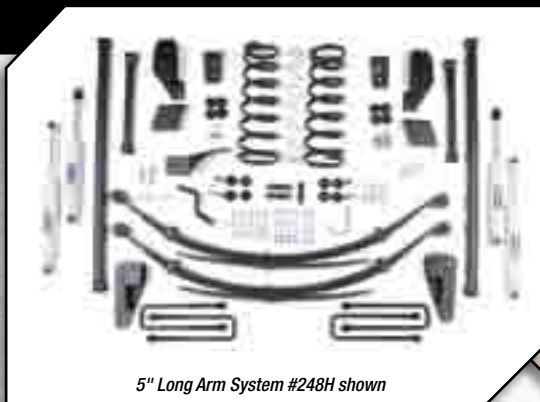

5" Long Arm System #248H shown



1994-1999 DODGE RAM 1500 4WD TRUCK

Lift & Method	Qty	Part#	Description	Recommended Accessories	Notes
2" Front / 0" Rear Front Coil Spacers Kit #204H 09DK153	1	012201	Front Spacer Kit	98224710 FOX 2.0 Front Gas Shock - 2" kit (2 req'd)	
	2	55710	Front 5500 Shock	98224719 FOX 2.0 Rear Gas Shock - 2" kit (2 req'd)	
	2	55719	Rear 5500 Shock	98224700 FOX 2.0 Front Gas Shock - 3" kit (2 req'd)	
				98224759 FOX 2.0 Rear Gas Shock - 3" kit (2 req'd)	
3" Front / 3" Rear Front Coil Spacers Rear Blocks & Add-A-Leafs Kit #242H 07DK245	1	012301	Front Spacer Kit	122301 Front Dual Shock Bracket Kit	1
	1	012309	Rear Kit	55620 Dual 5500 Shock - 2" Kit (2 req'd)	
	2	55700	Front 5500 Shock	55650 Dual 5500 Shock - 3" Kit (2 req'd) or	
	2	55759	Rear 5500 Shock	98224650 FOX 2.0 Front Gas Shock - 3" Kit (2 req'd)	
				55406 Single Steering Stabilizer	
				55351 Dual Steering Stabilizer Bracket	
				55405 Dual Steering Stabilizer (2 req'd)	
				122305 Upper & Lower Control Arm Kit	
				PSL400 4x4 Posi-Lok™ (page 119)	
5" Front / 5" Rear Standard Kit Front Coils & Brackets Rear Shackle Flip Kit #243H 18DK9241	1	032501	Front Coil Springs	98224750 FOX 2.0 Front Gas Shock (2 req'd)	2
	1	012503	Front Box Kit	98224761 FOX 2.0 Rear Gas Shock (2 req'd)	3
	1	012509	Rear Shackle Flip Kit	122303 Front Dual Shock Bracket Kit	4
	1	55417	Single Steering Stabilizer	55650 Dual 5500 Shock (2 req'd) or	5
	2	55750	Front 5500 Shock	98224620 FOX 2.0 Dual Gas Shock (2 req'd)	
	2	55761	Rear 5500 Shock	55351 Dual Steering Stabilizer Bracket Kit	
				55404 Dual Steering Stabilizer (2 req'd)	
				PSL400 4x4 Posi-Lok™ (page 119)	
5" Front / 5" Rear Long Arm Kit Front Coils & Brackets Rear Shackle Flip Kit #244H 48DK6771	1	032501	Front Coil Springs		
	1	012511	Long Arm Kit - box 1 of 2		
	1	012513	Long Arm Kit - box 2 of 2		
	1	012509	Rear Shackle Flip Kit		
	1	55417	Single Steering Stabilizer		
	2	55750	Front 5500 Shock		
	2	55761	Rear 5500 Shock		
5" Front / 4.5" Rear Standard Kit Front Coils & Brackets Rear Blocks & Add-A-Leafs Kit #245H 90DK7531	1	032501	Front Coil Springs		2
	1	012503	Front Box Kit		4
	1	012307	Rear 3" Block Kit		
	1	119157	Rear Add-A-Leaf		
	1	55417	Single Steering Stabilizer		
	2	55750	Front 5500 Shock		
	2	55761	Rear 5500 Shock		
5" Front / 4.5" Rear Long Arm Kit Front Coils & Brackets Rear Blocks & Add-A-Leafs Kit #246H 21DK4071	1	032501	Front Coil Springs		
	1	012511	Long Arm Kit - box 1 of 2		
	1	012513	Long Arm Kit - box 2 of 2		
	1	012307	Rear 3" Block Kit		
	1	119157	Rear Add-A-Leaf		
	1	55417	Single Steering Stabilizer		
	2	55750	Front 5500 Shock		
	2	55761	Rear 5500 Shock		
5" Front / 4.5" Rear Standard Kit Front Coils & Brackets Rear Leaf Springs Kit #247H 50DK3261	1	032501	Front Coil Springs		2
	1	012503	Front Box Kit		4
	2	002459	Rear Leaf Spring		6
	4	4045	9/16 x 2-9/16 x 11-3/8" Rear U-Bolt		
	1	55417	Single Steering Stabilizer		
	2	55750	Front 5500 Shock		
	2	55761	Rear 5500 Shock		
5" Front / 4.5" Rear Long Arm Kit Front Coils & Brackets Rear Leaf Springs Kit #248H 80DK0791	1	032501	Front Coil Springs		
	1	012511	Long Arm Kit - box 1 of 2		
	1	012513	Long Arm Kit - box 2 of 2		
	2	002459	Rear Leaf Spring		
	4	4045	9/16 x 2-9/16 x 11-3/8" Rear U-Bolt		
	1	55417	Single Steering Stabilizer		
	2	55750	Front 5500 Shock		
	2	55761	Rear 5500 Shock		



Notes

1. The front axle will shift laterally approximately 1/2".
2. For models built after February 9, 1994 due to track bar stud size.
3. The rear axle will be shifted forward in the wheel well.
4. Single stabilizer may be replaced with dual stabilizer.
5. May require exhaust modification.
6. #002459 rear springs come with OE style bushings installed.

2014 DODGE RAM 4WD 2500 TRUCK - DIESEL

FRONT RADIUS ARM REAR 4-LINK COIL



Vehicle Specs:
6" 4-link system
37" Nitto M/T
22" XD Badland



#1602H - 4" 4-Link Kit

The 2014 RAM 2500 4WD trucks have undergone a complete overhaul to the chassis and suspension. Up front the trucks now use a factory radius arm setup while out back the leaf springs have been replaced with coil springs and 4-link setup. BDS offers multiple kit options to include 2" leveling, 4" and 6" radius arm drop bracket kits, and 4" and 6" 4-link conversion lift kits for trucks equipped with the 6.7L Cummins diesel. Shown is the 4" 4-Link System, kit features include:

- Front & Rear Progressive Rate Coils
- 4-Link Conversion Brackets and Control Arms
- Heavy Duty Front & Rear Track Bar Brackets
- Forged Drop Pitman Arm to correct steering angles
- T-Case Indexing Kit and low-profile Transmission Crossmember (6" kit only)
- Bump Stops, Sway Bar Links, 5500 or Fox 2.0 Shocks



Steering Stabilizer - #55370/55422

2014 DODGE RAM 2500 4WD TRUCK - DIESEL

Lift & Method	Qty	Part#	Description	Recommended Accessories	Notes
2" Front / 0" Rear Front Coil Mount Kit #695H 76DK453	1 2 2	012203 55710 55705	2" Leveling Kit Front 5500 Series Shock Rear 5500 Series Shock	98224710 FOX 2.0 Front Gas Shock (2 req'd) 98224705 FOX 2.0 Rear Gas Shock (2 req'd) 55427 5500 Steering Stabilizer (ea.) or 95427 9500 Steering Stabilizer (ea.) or 98224018 FOX 2.0 Steering Stabilizer 122314 Front Adjustable Track Bar	
4" Front / 2.5" Rear Standard Kit Progressive Rate Coils Rear Coil Spacer Kit #698H 10DK4131	1 1 1 2 2	032401 012401 012259 55752 55757	Front 4" Coil Springs - Diesel 4" Front Box Kit 2.5" Rear Coil Spacer Kit Front 5500 Series Shock Rear 5500 Series Shock	98224752 FOX 2.0 Front Gas Shock - 4-6" kit (2 req'd) 98224705 FOX 2.0 Rear Gas Shock - 4" kit (2 req'd) 98224752 FOX 2.0 Rear Gas Shock - 6" kit (2 req'd) 122615 Dual Shock Mounting Kit 55759 Dual 5500 Shock (4 req'd) or 98224759 FOX 2.0 Dual Gas Shock (4 req'd)	1 2
4" Front / 2.5" Rear Standard Kit Front Progressive Rate Coils Rear Progressive Rate Coils Kit #1601H 69DK0341	1 1 1 2 2	032401 012401 012258 55752 55757	Front 4" Coil Springs - Diesel 4" Front Box Kit 2.5" Rear Coil Kit Front 5500 Series Shock Rear 5500 Series Shock	55427 Single 5500 Steering Stabilizer or 95427 Single 9500 Steering Stabilizer or 98224018 FOX 2.0 Steering Stabilizer 55370 Dual Steering Stabilizer Bracket Kit 55422 5500 Dual Steering Stabilizer (2 req'd) or 95422 9500 Dual Steering Stabilizer (2 req'd) or 98224016 FOX 2.0 Dual Steering Stabilizer (2 req'd)	
4" Front / 2.5" Rear 4-Link System Front Progressive Rate Coils Rear Progressive Rate Coils Kit #1602H 78DK7112	1 1 1 2 2	032401 012403 012414 012258 55752 55757	Front 4" Coil Springs - Diesel 4-Link Box Kit (2of2) 4-Link Box Kit (1of2) 2.5" Rear Coil Kit Front 5500 Series Shock Rear 5500 Series Shock	122314 Front Adjustable Track Bar 102003 Front Stainless Brake Lines (pr)	
6" Front / 4.5" Rear Standard Kit Front Progressive Rate Coils Rear Progressive Rate Coils Kit #1600H 89DK2591	1 1 1 1 2 2	032602 012610 122613 012458 55752 55756	Front 6" Coil Springs - Diesel 6" Front Box Kit 6-Bolt T-Case Indexing Kit 4.5" Rear Coil Box Kit Front 5500 Series Shock Rear 5500 Series Shock		1 2 3
6" Front / 4.5" Rear 4-Link System Front Progressive Rate Coils Rear Progressive Rate Coils Kit #1604H 98DK8852	1 1 1 1 1 2 2	032602 012604 012403 122613 012458 55752 55756	Front 6" Coil Springs - Diesel 6" 4-Link Box Kit (1of2) 4-Link Box Kit (2of2) 6-Bolt T-Case Indexing Kit 4.5" Rear Coil Springs Kit Front 5500 Series Shock Rear 5500 Series Shock		



#122314 - Adjustable Track Bar

#122813 - 8-Bolt Transfer Case (see note 3)

- Notes:**
1. Not for use with factory rear airbag suspensions
 2. Fits Diesel Models Only
 3. Indexing ring only fits 6 bolt transfer cases (most common). Some heavy-duty tow package vehicle could have 8-bolt transfer cases (w/Heavy-duty Aisin 6 speed transmissions), order 122813.

2014 DODGE RAM 4WD 2500 TRUCK - GAS

FRONT RADIUS ARM REAR 4-LINK COIL

CHEVROLET/
GMC

DODGE

FORD

JEEP

SUZUKI

TOYOTA

POSI-LOK

SHOCKS/
STEERING
STABILIZERS

APPAREL/
PROMOTIONAL

PRODUCT
SPECS

VEHICLE
SPECS



#1605H - 5.5" Kit

The 2014 RAM 2500 4WD trucks have undergone a complete overhaul to the chassis and suspension. Up front the trucks now use a factory radius arm setup while out back the leaf springs have been replaced with coil springs and 4-link setup. BDS offers multiple kit options to include 2" leveling and 5.5" kit designed for both retaining OE radius arms or converting to the 4-link setup. The 5.5" Standard kit includes:

- Front & Rear Progressive Rate Coils
- Heavy Duty Radius Arm Drop Brackets
- Heavy Duty Front & Rear Track Bar Brackets
- Forged Drop Pitman Arm to correct steering angles
- T-Case Indexing Kit and low-profile Transmission Crossmember
- Bump Stops, Sway Bar Links, 5500 or Fox 2.0 Shocks



Vehicle Specs:
5.5" lift kit
37" Nitto M/T
22" Halo 879



#695H - 2" Kit

2" Leveling Kit Features:

- Pitched & indexed coil spacers to correctly position front coils
- Polyurethane extended bump stops
- Front & rear shocks

2014 DODGE RAM 2500 4WD TRUCK - GAS

Lift & Method	Qty	Part#	Description	Recommended Accessories	Notes
2" Front / 0" Rear Front Coil Mount Kit #695H 76DK453	1	012203	2" Leveling Kit	98224710 FOX 2.0 Front Gas Shock (2 req'd)	
	2	55710	Front 5500 Series Shock	98224705 FOX 2.0 Rear Gas Shock (2 req'd)	
	2	55705	Rear 5500 Series Shock	55427 5500 Steering Stabilizer (ea.) or 95427 9500 Steering Stabilizer (ea.) 122314 Front Adjustable Track Bar	
5.5" Front / 4.5" Rear Standard Kit Front Progressive Rate Coils Rear Progressive Rate Coils Kit #1605H 61DK4391	1	032401	Front 5.5" Coil Springs - Gas	98224752 FOX 2.0 Front Gas Shock - 4-6" kit (2 req'd)	1
	1	012610	Front Box Kit	98224705 FOX 2.0 Rear Gas Shock - 4" kit (2 req'd)	
	1	122613	6-Bolt T-Case Indexing Kit	98224752 FOX 2.0 Rear Gas Shock - 6" kit (2 req'd)	
	1	012458	4.5" Rear Coil Box Kit	122615 Dual Shock Mounting Kit	
	2	55752	Front 5500 Series Shock	55759 Dual 5500 Shock (4 req'd) or 98224759 FOX 2.0 Dual Gas Shock (4 req'd)	
	2	55756	Rear 5500 Series Shock	55427 Single 5500 Steering Stabilizer or 95427 Single 9500 Steering Stabilizer or 98224018 FOX Single Steering Stabilizer	
5.5" Front / 4.5" Rear 4-Link System Front Progressive Rate Coils Rear Progressive Rate Coils Kit #1606H 70DK0752	1	032401	Front 5.5" Coil Springs - Gas	55370 Dual Steering Stabilizer Bracket Kit	
	1	012604	4-Link Box Kit (1of2)	55422 5500 Dual Steering Stabilizer (2 req'd) or 95422 9500 Dual Steering Stabilizer (2 req'd) or 98224016 FOX 2.0 Dual Steering Stabilizer (2 req'd)	
	1	012403	4-Link Box Kit (2of2)	122314 Front Adjustable Track Bar	
	1	122613	6-Bolt T-Case Indexing Kit	102003 Front Stainless Brake Lines (pr)	
	1	012458	4.5" Rear Coil Springs Kit	122405 Carrier Bearing Drop Kit	
	2	55752	Front 5500 Series Shock		
2	55756	Rear 5500 Series Shock			

Notes:

1. Not for use with factory rear airbag suspensions
2. Indexing ring only fits 6 bolt transfer cases (most common). Some heavy-duty tow package vehicle could have 8 bolt transfer cases (w/Heavy-duty Aisin 6 speed transmissions)



#98224018 -

FOX Single Steering Stabilizer

2013-2014 DODGE RAM 3500 4WD TRUCK - DIESEL

FRONT RADIUS ARM REAR LEAF SPRING

DODGE

FORD

JEEP

SUZUKI

TOYOTA

POSI-LOK

SHOCKS/
STEERING
STABILIZERS

APPAREL/
PROMOTIONAL

PRODUCT
SPECS

VEHICLE
SPECS

BDS Suspension leads the industry with a number of first-to-market suspension options for the new 2013 RAM 3500 trucks with front radius arm style suspension. From specially designed 2" leveling kits to complete 4" and 6" radius arm drop bracket kits and revolutionary 4" and 6" 4-link conversion lift kits, BDS offers a wide variety of suspension lifts to meet your needs. In addition to kits, BDS offers a number of accessories, Fox 2.0 shocks, adjustable track bars, steering stabilizers and traction bars. As with other BDS kits, these are backed by the Factory Protection Plus program.



#012203 - 2" Coil Spacers
(kit includes bump stops
and hardware)

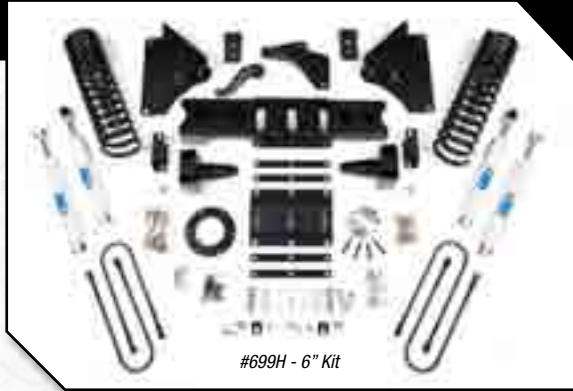

#699H - 6" Kit

2013-2014 DODGE RAM 3500 4WD TRUCK - DIESEL

Lift & Method	Qty	Part#	Description	Recommended Accessories	Notes
2" Front / 0" Rear	1	012203	2" Leveling Kit	98224710	
Front Coil Mount	2	55710	Front 5500 Series Shock	98224759	
Kit #694H 76DK453	2	55759	Rear 5500 Series Shock	55427 5500 Steering Stabilizer (ea.) or 95427 9500 Steering Stabilizer (ea.) or 98224018 FOX 2.0 Steering Stabilizer 122314 Front Adjustable Track Bar	
4" Front / 3" Rear	1	032401	Front 4" Coil Springs - Diesel	98224752	2 3
Standard Kit	1	012401	4" Radius Arm Drop Box Kit	98224759	
Front Progressive Rate Coils	1	012317	3" Rear Block Kit	98224761	
Rear Block Kit	2	55752	Front 5500 Series Shock	122615	
Kit #696H 38DK7011	2	55759	Rear 5500 Series Shock	55759 98224759	
4" Front / 3" Rear	1	032401	Front 4" Coil Springs - Diesel	55427	
4-Link System	1	012403	4-Link Box Kit	95427	
Front Progressive Rate Coils	1	012414	4-Link Box Kit	98224018	FOX 2.0 Dual Gas Shock (4 req'd) Single 5500 Steering Stabilizer or Single 9500 Steering Stabilizer or FOX 2.0 Steering Stabilizer
& Longarm, Rear Block Kit	1	012317	3" Rear Box w/4	55370	
Kit #697H 47DK4971	2	55752	Front 5500 Series Shock	55422	
	2	55759	Rear 5500 Series Shock	95422 9500 Dual Steering Stabilizer (2 req'd) or 98224016 FOX 2.0 Dual Steering Stabilizer (2 req'd)	
6" Front / 5" Rear	1	032602	Front 6" Coil Springs - Diesel	122314	1 2 3
Standard Kit	1	012610	6" Front Box Kit	122618	
Front Progressive Rate Coils	1	122613	6-Bolt T-Case Indexing Kit	012207	
Rear Block Kit	1	012516	Dodge 5" Rear Block Kit w/4"	102003	
Kit #699H 24DK1461	2	55752	Front 5500 Series Shock		
	2	55761	Rear 5500 Series Shock		
6" Front / 5" Rear	1	032602	Front 6" Coil Springs - Diesel		
4-Link System	1	012604	6" 4-Link Box Kit (1of2)		
Front Progressive Rate Coils	1	012403	4-Link Box Kit (2of2)		
& Longarm, Rear Block Kit	1	122613	6-Bolt T-Case Indexing Kit		
Kit #1603 98DK8852	1	012516	Rear Block Kit		
	2	55752	Front 5500 Series Shock		
	2	55761	Rear 5500 Series Shock		

ACCESSORIES



#122813 -
8-Bolt
Transfer Case
(see note 1)

Notes:

1. Indexing ring 122613 only fits 6 bolt transfer cases (most common). Some heavy-duty tow package vehicle could have 8 bolt transfer cases (w/Heavy-duty Aisin 6 speed transmissions), order 122813.
2. Diesel Only.

Vehicle Specs:
6" Lift Kit
37" Toyo M/Ts
22" American Forces



2013-2014 DODGE RAM 3500 4WD TRUCK - GAS

FRONT RADIUS ARM REAR LEAF SPRING

CHEVROLET/
GMC

DODGE

FORD

JEEP

SUZUKI

TOYOTA

POSI-LOK

SHOCKS/
STEERING
STABILIZERS

APPAREL/
PROMOTIONAL

PRODUCT
SPECS

VEHICLE
SPECS



#1608H - 5.5" Kit

The 2013-2014 RAM 3500 4WD trucks have undergone a front end overhaul. After 10 years of the front 4-link setup RAM HDs have been converted over to a front radius arm suspension. BDS has multiple options for the gas engine equipped trucks ranging from 2" leveling kits up to 5.5" systems. Shown is the 5.5" 4-Link System, kit features include:

- Front Progressive Rate Coils
- 4-Link Conversion Brackets and Control Arms
- Heavy Duty Front Track Bar Brackets
- Forged Drop Pitman Arm to correct steering angles
- T-Case Indexing Kit and low-profile Transmission Crossmember
- Bump Stops, Rear Block and U-Bolt Kit, 5500 or Fox 2.0 Shocks

Vehicle Specs:
5.5" Lift Kit
37" Interco M16
20" BMF Novakane



2013-2014 DODGE RAM 3500 4WD TRUCK - GAS

Lift & Method	Qty	Part#	Description	Recommended Accessories	Notes
2" Front / 0" Rear Front Coil Mount Kit #694H 76DK453	1	012203	2" Leveling Kit	98224710	
	2	55710	Front 5500 Series Shock	98224759	
	2	55759	Rear 5500 Series Shock	55427 95427 122314	
5.5" Front / 5" Rear Standard Kit Front Progressive Rate Coils Rear Block Kit Kit #1607H 06DK2261	1	032401	Front 5.5" Coil Springs - Gas	98224752	1 2
	1	012610	5.5" Front Box Kit	98224759	
	1	122613	6-Bolt T-Case Indexing Kit	98224761	
	1	012516	Dodge 5" Rear Block Kit w/4"	122615	
	2	55752	Front 5500 Series Shock	55759	
	2	55761	Rear 5500 Series Shock	98224759	
5.5" Front / 5" Rear 4-Link System Front Progressive Rate Coils & Longarm, Rear Block Kit Kit #1608H 15DK8522	1	032401	Front 5.5" Coil Springs - Gas	55427	
	1	012604	5.5" 4-Link Box Kit (1of2)	95427	
	1	012403	4-Link Box Kit (2of2)	98224018	
	1	122613	6-Bolt T-Case Indexing Kit	55370	
	1	012516	Rear Block Kit	55422	
	2	55752	Front 5500 Series Shock	95422	
	2	55761	Rear 5500 Series Shock	98224016	
				122314	
				122618	
				102003	
			122405		
			012407		

Notes:

1. Indexing ring only fits 6 bolt transfer cases (most common). Some heavy-duty tow package vehicle could have 8 bolt transfer cases (w/Heavy-duty Aisin 6 speed transmissions)
2. For rear leaf spring equipped models only.

ACCESSORIES



#122314 - Front Adjustable Track Bar



#122618 - Traction Bar Kit

2009-2013 DODGE RAM 2500, 2009-2012 DODGE RAM 3500 4WD TRUCK - DIESEL PRO-RIDE SYSTEM

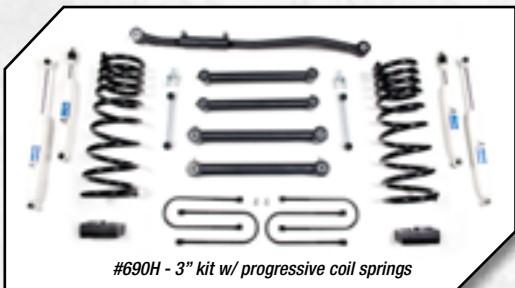

#690H - 3" kit w/ progressive coil springs



#632H - 8" Longarm kit

3" Performance Kit Features

- Greaseable control arms to reposition the front axle
- Heavy duty adjustable track bar to recenter axle
- Extended sway bar links w/ stem eliminator
- Rear block kit and (4) shocks

6" and 8" Long Arm Kit Features

- Progressive rate coil springs
- Heavy duty 4-link long arm brackets and formed control arms improve all around performance by reducing caster change through wheel travel.
- Forged pitman arm and track bar bracket reposition steering.
- T-Case Indexing Ring (option on the 6" kit) to reposition drivelines to function properly.
- Choice of rear block or replacement leaf springs
- Choice of 5500 or Fox 2.0 shocks with numerous mounting configurations

2009-2013 DODGE RAM 2500 & 2009-2012 3500 4WD TRUCK - DIESEL (INCLUDING MEGA CAB)

Lift & Method	Qty	Part#	Description	Recommended Accessories	Notes
2" Front/ 0" Rear Front Coil Spacers Kit #223H 09DK153	1	012201	2" Front Spacer Kit	98224700	
	2	55700	Front 5500 Shock	98224759	
	2	55759	Rear 5500 Shock	55422	
3" Front / 2" Rear Front Coil Spacers Rear Block Kit 4" Axle Kit #604H 77DK707	1	012322	3" Front Box Kit	122315	1 2
	1	012207	2" Rear Block	122618	
	2	55700	Front 5500 Shock	102001	
4" Axle Kit #690H 50DK0031	2	55700	Front 5500 Shock		
	2	55759	Rear 5500 Shock		
	1	032301	3" Progressive Rate Coil (pr.)		
3" Front / 2" Rear Progressive Coil Springs Rear Block Kit	1	012304	Front Box Kit		
	1	012207	2" Rear Block		



See Notes ►

Continued ►



Vehicle Specs:
8" Lift Kit
40" Toyo M/T
20" BMF Novakane
(Trimming required)



Vehicle Specs:
8" Lift Kit
38" Nitto M/Ts
24x14 American Force

2009-2013 DODGE RAM 2500 & 2009-2012 DODGE RAM 3500 4WD TRUCK - DIESEL (INCLUDING MEGA CAB)

Lift & Method	Qty	Part#	Description	Recommended Accessories	Notes
6" Front / 4" Rear Standard Kit Front Coils & Brackets Rear Block Kit 4" Axle Kit #607H 61DK5031	1	032503	Front Coil Springs	SHOCKS 98224750 FOX 2.0 Front Gas Shock - 6" kit (2 req'd) 98224751 FOX 2.0 Front Gas Shock - 8" kit (2 req'd) 98224761 FOX 2.0 Rear Gas Shock - 6-8" kit (2 req'd) 122604 Dual Auxiliary Hoop Mount (short arm only) or 122614 Dual Auxiliary Hoop Mount (long arm only) 55920 Dual 5500 Front Shock (4 req'd) or 98224920 FOX 2.0 Dual Front Gas Shock (4 req'd) 122009 Dual Rear Shock Mount 55761 Dual 5500 Rear Shock (2 req'd) or 98224761 FOX 2.0 Dual Rear Gas Shock (2 req'd)	1 2 3 4 6
	1	012622	Front Box Kit		
	1	012405	Rear Block Kit for 4" axle		
	2	55750	Front 5500 Shock		
	2	55761	Rear 5500 Shock		
6" Front / 5" Rear Standard Kit Front Coils & Brackets Rear Leaf Spring 4" Axle Kit #673H 46DK7012	1	032503	Front Coil Springs	STABILIZERS 55422 Single 5500 Steering Stabilizer or 95422 Single 9500 Steering Stabilizer 55369 Dual Steering Stabilizer Mount 55422 Dual 5500 Steering Stabilizer (2 req'd) or 95422 Dual 9500 Steering Stabilizer (2 req'd)	
	1	012622	Front Box Kit		
	2	002508	Rear Leaf Springs		
	4	4067	9/16"x4"x12-1/2" U-Bolt		
	2	55750	Front 5500 Shock		
6" Front /4" Rear Long Arm Kit Front Coils & Brackets Rear Block Kit 4" Axle Kit #629H 61DK6091	1	032503	Front Coils Springs	T-CASE/DRIVELINE MODIFICATION 122501 Carrier Bearing Drop Kit 122605 T-Case Drop Bracket - 6" kit - Manual 122606 T-Case Drop Bracket - 6" kit - Auto 122801 T-Case Indexing Ring Kit - Auto (included in 8" long arm kits) 122802 T-Case Indexing Ring Kit - Manual	
	1	012802	Control Arm Box Kit		
	1	012801	Control Arm Mounts		
	1	012601	Front 6" Box Kit		
	1	012405	Rear Block Kit for 4" Axle		
6" Front /5" Rear Long Arm Kit Front Coils & Brackets Rear Leaf Spring 4" Axle Kit #674H 46DK8072	1	032503	Front Coil Springs	TRACTION BARS 122618 4" Axle Traction Bar Kit	1 2 4 5 6
	1	012802	Control Arm Box Kit		
	1	012801	Control Arm Mounts		
	1	012601	Front 6" Box Kit		
	2	002508	Rear Leaf Spring		
8" Front / 5" Rear Long Arm Kit Front Coils & Brackets Rear Block Kit 4" Axle Kit #632H 30DK4512	1	032801	Front Coils Springs	ACCESSORIES 102001 Front SS Brake Lines (pr.) 102009 Rear SS Brake Line 122315 HD Adjustable Track Bar	
	1	012801	Control Arm Mounts		
	1	012802	Control Arm Box Kit		
	1	012803	Front 8" Box Kit		
	1	122801	T-Case Indexing Kit - Auto		
8" Front / 5" Rear Long Arm Kit Front Coils & Brackets Rear Leaf Spring 4" Axle Kit #675H 71DK5192	1	032801	Front Coil Springs		
	1	012801	Control Arm Mounts		
	1	012802	Control Arm Box Kit		
	1	012803	Front 8" Box Kit		
	1	122801	T-Case Indexing Kit - Auto		

- Notes
1. Measure rear axle tube before ordering. Some 4" axle models with dual overloads will require 4068.
 2. Rear lift options will not fit dually applications.
 3. If driveline vibration occurs, order either transfer case drop or indexing kit available in optional accessories. NOTE: 122606 Transmission drop kit will only replace the OE bracket #52121938AA
 4. 102009 Rear brake lines will not fit 2012-2013 models.
 5. Additional front driveline modification may be required.
 6. Exhaust modification will be required for dual rear shock kit 122009.

2009-2013 DODGE RAM 2500, 2009-2012 DODGE RAM 3500 4WD TRUCK - GAS PRO-RIDE SYSTEM

DODGE

FORD

JEEP

SUZUKI

TOYOTA

POSI-LOK

SHOCKS/
STEERING
STABILIZERS

APPAREL/
PROMOTIONAL

PRODUCT
SPECS

VEHICLE
SPECS

2009-2013 DODGE RAM 2500 & 2009-2012 DODGE RAM 3500 4WD TRUCK - GAS (INCLUDING MEGA CAB)

Lift & Method	Qty	Part#	Description	Recommended Accessories	Notes
2" Front/ 0" Rear Front Coil Spacers Kit #223H 09DK153	1	012201	2" Front Spacer Kit	98224700	4
	2	55700	Front 5500 Shock	98224759	
	2	55759	Rear 5500 Shock	55422	
3" Front / 2" Rear Front Coil Spacers Rear Block Kit 3-1/2" axle Kit #600H 4" axle Kit #604H 77DK707	1	012322	3" Front Box Kit	122315	1 4
	1	012208	2" Rear Block Kit for 3-1/2" axle or	122618	
	1	012207	2" Rear Block Kit for 4" axle	122619	
	2	55700	Front 5500 Shock	102001	
	2	55759	Rear 5500 Shock		
6" Front/ 4" Rear Standard Kit Front Coils & Bracket Kit Rear Block Kit 3-1/2" axle Kit #601H 4" axle Kit #612H 68DK9131	1	032601	Front Coil Springs	SHOCKS 98224750 FOX 2.0 Front Gas Shock - 6" kit (2 req'd) 98224751 FOX 2.0 Front Gas Shock - 8" kit (2 req'd) 98224759 FOX 2.0 Rear Gas Shock - 6-8" kit (2 req'd) 122604 Dual Auxiliary Hoop Mount (short arm only) or 122614 Dual Auxiliary Hoop Mount (long arm only) 55920 Dual 5500 Front Shock (4 req'd) or 98224920 FOX 2.0 Dual Front Gas Shock (4 req'd) 122009 Dual Rear Shock Mount 55761 Dual 5500 Rear Shock (2 req'd) or 98224761 FOX 2.0 Dual Rear Gas Shock (2 req'd)	1 2 3 5 6
	1	012622	Front Box Kit		
	1	012408	Rear Block Kit for 3-1/2" Axle or		
	1	012405	Rear Block Kit for 4" Axle		
	2	55750	Front 5500 Shock		
	2	55761	Rear 5500 Shock		
6" Front/ 5" Rear Standard Kit Front Coils & Bracket Kit Rear Leaf Spring 3-1/2" axle Kit #676H 4" axle Kit #677H 43DK2212	1	032601	Front Coil Springs	STABILIZERS 55422 Single 5500 Steering Stabilizer or 95422 Dual 9500 Steering Stabilizer 55369 Dual Steering Stabilizer Mount 55422 Dual 5500 Steering Stabilizer (2 req'd) or 95422 Dual 9500 Steering Stabilizer (2 req'd)	1 2 3 5 6
	1	012622	Front Box Kit		
	2	002508	Rear Leaf Spring		
	4	4064	9/16"x3-1/2"x12-1/2" U-Bolt or		
	4	4067	9/16"x4"x12-1/2" U-Bolt		
	2	55750	Front 5500 Shock		
6" Front /4" Rear Long Arm Kit Front Coils & Brackets Rear Block Kit 3-1/2" axle Kit # 633H 4" axle Kit # 635H 68DK0291	1	032601	Front Coils Springs	T-CASE/DRIVELINE MODIFICATION 122501 Carrier Bearing Drop Kit 122605 T-Case Drop Bracket - 6" kit - Manual 122606 T-Case Drop Bracket - 6" kit - Auto 122801 T-Case Indexing Ring Kit - Auto (included in 8" long arm kits) 122802 T-Case Indexing Ring Kit - Manual	1 2 3 5 6
	1	012802	Control Arm Box Kit		
	1	012801	Control Arm Mounts		
	1	012601	Front 6" Box Kit		
	1	012408	Rear Block Kit for 3-1/2" Axle or		
	1	012405	Rear Block Kit for 4" Axle		
6" Front /5" Rear Long Arm Kit Front Coils & Brackets Rear Leaf Spring 3-1/2" axle Kit #678H 4" axle Kit #679H 43DK3272	1	032601	Front Coil Springs	TRACTION BARS 122619 3.5" Axle Traction Bar Kit 122618 4" Axle Traction Bar Kit	1 2 4 5 6
	1	012802	Control Arm Box Kit		
	1	012801	Control Arm Mounts		
	1	012601	Front 6" Box Kit		
	2	002508	Rear Leaf Spring		
	4	4064	9/16"x3-1/2"x12-1/2" U-Bolt or		
8" Front / 5" Rear Long Arm Kit Front Coils & Brackets Rear Block Kit 3-1/2" axle 4" axle 27DK6432	1	032601	Front Coils Springs	ACCESSORIES 102001 Front SS Brake Lines (pr.) 102009 Rear SS Brake Line 122315 HD Adjustable Track Bar	1 2 4 5 6
	1	012201	2" Front Spacer Kit		
	1	012801	Control Arm Mounts		
	1	012802	Control Arm Box Kit		
	1	012803	Front 8" Box Kit		
	1	122801	T-Case Indexing Kit - Auto		
8" Front / 5" Rear Long Arm Kit Front Coils & Brackets Rear Leaf Spring 3-1/2" axle 4" axle 87DK9013	1	032601	Front Coil Springs		
	1	012201	2" Front Spacer Kit		
	1	012801	Control Arm Mounts		
	1	012802	Control Arm Box Kit		
	1	012803	Front 8" Box Kit		
	1	122801	T-Case Indexing Kit - Auto		



Notes

1. Measure rear axle tube before ordering. Some 4" axle models with dual overloads will require 4068.
2. Rear lift options will not fit dually applications.
3. If driveline vibration occurs, order either transfer case drop or indexing kit available in optional accessories. NOTE: 122606 Trans-
mission drop kit will only replace the OE bracket #52121938AA
4. Not recommended for Power Wagon applications.
5. Power Wagon applications require sway bar link kit #122401. The Power Wagon has a 2" taller ride height, so net lift gain will be 4".
6. 102009 rear brake lines for 2012-2013 models.

2008 DODGE RAM 2500 & 3500 4WD TRUCK - DIESEL PRO-RIDE SYSTEM

CHEVROLET/
GMC

DODGE

FORD

JEEP

SUZUKI

TOYOTA

POSI-LOK

SHOCKS/
STEERING
STABILIZERS

APPAREL/
PROMOTIONAL

PRODUCT
SPECS

VEHICLE
SPECS

3" Performance System Features

- 3" progressive rate Pro-Ride coils
- 1.5" OD x.250-wall upper/lower greaseable control arms to reposition the front axle
- Heavy duty adjustable track bar to recenter axle
- Extended sway bar links w/ stem eliminator
- Rear block kit and (4) shocks

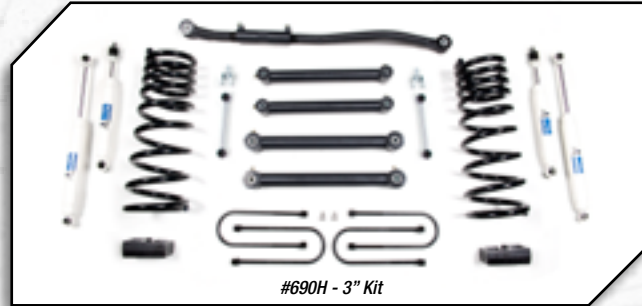

#690H - 3" Kit

2008 DODGE RAM 2500 & 3500 4WD TRUCK - DIESEL (INCLUDING MEGA CAB)

Lift & Method	Qty	Part#	Description	Recommended Accessories	Notes
2" Front/ 0" Rear Front Coil Spacers Kit #223H 09DK153	1	012201	2" Front Spacer Kit	98224700	
	2	55700	Front 5500 Shock	98224759	
3" Front / 2" Rear Front Coil Spacers Rear Block Kit 3-1/2" Axle Kit #281H 4" Axle Kit #283H 77DK707	1	012323	3" Front Box Kit	55424	1
	1	012208	2" Rear Block Kit for 3-1/2" axle or	122315	
3" Front / 2" Rear Progressive Coil Springs Rear Block Kit 4" Axle Kit #690H 3.5" Axle Kit #691H 50DK0031	1	012207	2" Rear Block Kit for 4" axle	122618	
	2	55700	Front 5500 Shock	122619	
4" Axle Kit #283H 77DK707	2	55759	Rear 5500 Shock	102001	
	2	55759	Rear 5500 Shock		
3" Front / 2" Rear Progressive Coil Springs Rear Block Kit 4" Axle Kit #690H 3.5" Axle Kit #691H 50DK0031	1	032301	3" Progressive Rate Coil (pr.)		
	1	012304	Front Box Kit		
4" Axle Kit #690H 3.5" Axle Kit #691H 50DK0031	1	012207	Rear Kit for 4" Axle or		
	1	012208	Rear Kit for 3.5 Axle		
4" Axle Kit #690H 3.5" Axle Kit #691H 50DK0031	2	55700	Front 5500 Shock		
	2	55759	Rear 5500 Shock		

ACCESSORIES



#102001

See Notes ►

Continued ►

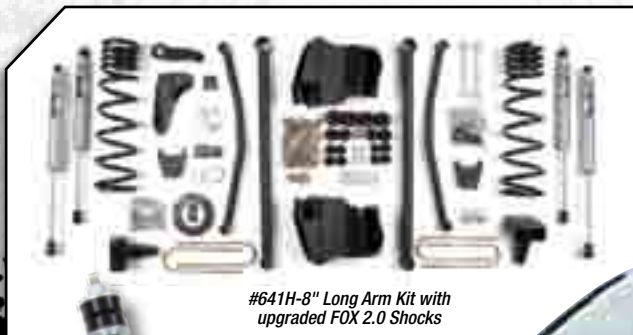

#641H-8" Long Arm Kit with
upgraded FOX 2.0 Shocks

6" & 8" Long Arm Kit Features

- Pro-Ride coil springs
- Extended length upper and lower control arms to reduce caster change through wheel travel
- Pitman arm for steering correction
- Extended bump stops
- Track bar relocation



Vehicle Specs:
3" Lift Kit
35" M/T ATZ
20" Racelines



Vehicle Specs:
8" Lift Kit
37x13.50 Nitto M/T
22x10.5 BMF Wheel

2008 DODGE RAM 2500 & 3500 4WD TRUCK - DIESEL (INCLUDING MEGA CAB)

Lift & Method	Qty	Part#	Description	Recommended Accessories	Notes			
6" Front / 4" Rear Standard Kit Front Coils & Bracket Kit Rear Block Kit 3-1/2" Axle Kit #284H 4" Axle Kit #286H 61DK5031	1	032503	Front Coil Springs	SHOCKS 98224750 FOX 2.0 Front Gas Shock - 6" kit (2 req'd) 98224751 FOX 2.0 Front Gas Shock - 8" kit (2 req'd) 98224759 FOX 2.0 Rear Gas Shock - 6-8" kit (2 req'd) 122604 Dual Auxiliary Hoop Mount (short arm only) or 122614 Dual Auxiliary Hoop Mount (long arm only) 55920 Dual 5500 Front Shock (4 req'd) or 98224920 FOX 2.0 Dual Front Gas Shock (4 req'd) 122009 Dual Rear Shock Mount 55761 Dual 5500 Rear Shock (2 req'd) or 98224761 FOX 2.0 Dual Rear Gas Shock (2 req'd) STABILIZERS 55424 Single 5500 Steering Stabilizer or 95424 Dual 9500 Steering Stabilizer 55357 Dual Steering Stabilizer Mount 55416 Dual 5500 Steering Stabilizer (2 req'd) or 95416 Dual 9500 Steering Stabilizer (2 req'd) T-CASE/DRIVELINE MODIFICATION 122501 Carrier Bearing Drop Kit 122605 T-Case Drop Bracket - 6" kit - Manual 122606 T-Case Drop Bracket - 6" kit - Auto 122801 T-Case Indexing Ring Kit - Auto (included in 8" long arm kits) 122802 T-Case Indexing Ring Kit - Manual TRACTION BARS 122619 3.5" Axle Traction Bar Kit 122618 4" Axle Traction Bar Kit ACCESSORIES 102001 Front SS Brake Lines (pr.) 102009 Rear SS Brake Line 122315 HD Adjustable Track Bar	1	012621	Front Box Kit	1
	1	012408	Rear Block Kit for 3-1/2" axle or		2			
	1	012405	Rear Block Kit for 4" axle		3			
	2	55750	Front 5500 Shock		4			
	2	55761	Rear 5500 Shock					
	6" Front / 5" Rear Standard Kit Front Coils & Bracket Kit Rear Leaf Spring 3-1/2" Axle Kit #680H 4" Axle Kit #681H 46DK7012	1	032503		Front Coil Springs			
		1	012621		Front Box Kit			
		2	002508		Rear Leaf Spring			
		4	4064		9/16"x3-1/2"x12-1/2" U-Bolt or			
		4	4067		9/16"x4"x12-1/2" U-Bolt			
2		55750	Front 5500 Shock					
2		55761	Rear 5500 Shock					
6" Front / 4" Rear Long Arm Kit Front Coils & Brackets Rear Block Kit 3-1/2" Axle Kit # 636H 4" Axle Kit # 638H 61DK6091		1	032503	Front Coils Springs				
		1	012802	Control Arm Box Kit				
		1	012801	Control Arm Mounts				
	1	012602	Front 6" Box Kit					
	1	012408	Rear Block Kit for 3-1/2" axle or					
	1	012405	Rear Block Kit for 4" axle					
	2	55750	Front 5500 Shock					
	2	55761	Rear 5500 Shock					
	6" Front / 5" Rear Long Arm Kit Front Coils & Brackets Rear Leaf Spring 3-1/2" Axle Kit #682H 4" Axle Kit #683H 46DK8072	1	032503	Front Coil Springs				
		1	012802	Control Arm Box Kit				
1		012801	Control Arm Mounts					
1		012602	Front 6" Box Kit					
2		002508	Rear Leaf Spring					
4		4064	9/16"x3-1/2"x12-1/2" U-Bolt or					
4		4067	9/16"x4"x12-1/2" U-Bolt					
2		55750	Front 5500 Shock					
2		55761	Rear 5500 Shock					
8" Front / 5" Rear Long Arm Kit Front Coils & Brackets Rear Block Kit 3-1/2" Axle Kit # 639H 4" Axle Kit # 641H 30DK4512		1	032801	Front Coils Springs				
	1	012801	Control Arm Mounts					
	1	012802	Control Arm Box Kit					
	1	012804	Front 8" Box Kit					
	1	122801	T-Case Indexing Kit - Auto					
	1	012518	Rear Block Kit for 3-1/2" axle or					
	1	012516	Rear Block Kit for 4" axle					
	2	55751	Front 5500 Shock					
	2	55761	Rear 5500 Shock					
	8" Front / 5" Rear Long Arm Kit Front Coils & Brackets Rear Leaf Spring 3-1/2" Axle Kit #684H 4" Axle Kit #685H 71DK5192	1	032801	Front Coil Springs				
1		012802	Control Arm Box Kit					
1		012801	Control Arm Mounts					
1		012804	Front 8" Box Kit					
1		122801	T-Case Indexing Kit - Auto					
2		002508	Rear Leaf Spring					
4		4064	9/16"x3-1/2"x12-1/2" U-Bolt or					
4		4067	9/16"x4"x12-1/2" U-Bolt					
2		55751	Front 5500 Shock					
2		55761	Rear 5500 Shock					



#122604 - Dual Auxiliary Hoop Mount

Notes
 1. Measure rear axle tube before ordering. Some models with dual overloads will require 4068.
 2. Rear lift options will not fit dually applications.
 3. If driveline vibration occurs, order 122801 or 122802 transfer case index kit.
 4. Exhaust modification will be required for dual rear shock kit 122009.

2008 DODGE RAM 2500 & 3500 4WD TRUCK - GAS

PRO-RIDE SYSTEM

CHEVROLET/
GMC

2008 DODGE RAM 2500 & 3500 4WD TRUCK - GAS (INCLUDING MEGA CAB) • 2008 DODGE 1500 MEGA-CAB 4WD TRUCK

Lift & Method	Qty	Part#	Description	Recommended Accessories	Notes
2" Front/ 0" Rear Front Coil Spacers Kit #223H 09DK153	1	012201	2" Front Spacer Kit	98224700 FOX 2.0 Front Gas Shock (2 req'd)	3
	2	55700	Front 5500 Shock	98224759 FOX 2.0 Rear Gas Shock (2 req'd)	
	2	55759	Rear 5500 Shock	55424 Single Steering Stabilizer	
3" Front / 2" Rear Front Coil Spacers Rear Block Kit 3-1/2" axle Kit #281H 4" axle Kit #283H 77DK707	1	012323	3" Front Box Kit	122315 Adjustable Track Bar (Included in 690/691H)	1 3
	1	012208	2" Rear Block Kit for 3-1/2" axle or	122618 4" Traction Bar Kit	
	1	012207	2" Rear Block Kit for 4" axle	122619 3.5" Traction Bar Kit	
	2	55700	Front 5500 Shock	102001 Front SS Brake Lines (pr)	
	2	55759	Rear 5500 Shock		
6" Front/ 4" Rear Standard Kit Front Coils & Bracket Kit Rear Block Kit 3-1/2" axle Kit #290H 4" axle Kit #292H 68DK9131	1	032601	Front 6" Coil Springs	SHOCKS	1 2 4 5
	1	012621	Front Box Kit	98224750 FOX 2.0 Front Gas Shock - 6" kit (2 req'd)	
	1	012408	Rear Block Kit for 3-1/2" Axle or	98224751 FOX 2.0 Front Gas Shock - 8" kit (2 req'd)	
	1	012405	Rear Block Kit for 4" Axle	98224759 FOX 2.0 Rear Gas Shock - 6-8" kit (2 req'd)	
	2	55750	Front 5500 Shock	122604 Dual Auxiliary Hoop Mount (short arm only) or	
6" Front/ 5" Rear Standard Kit Front Coils & Bracket Kit Rear Leaf Spring 3-1/2" axle Kit #686H 4" axle Kit #687H 43DK2212	2	55761	Rear 5500 Shock	122614 Dual Auxiliary Hoop Mount (long arm only)	1 2 4 5
	1	032601	Front 6" Coil Springs	5920 Dual 5500 Front Shock (4 req'd) or	
	1	012621	Front Box Kit	98224920 FOX 2.0 Dual Front Gas Shock (4 req'd)	
	2	002508	Rear Leaf Spring	122009 Dual Rear Shock Mount	
	4	4064	9/16"x3-1/2"x12-1/2" U-Bolt or	55761 Dual 5500 Rear Shock (2 req'd) or	
6" Front/ 4" Rear Long Arm Kit Front Coils & Brackets Rear Block Kit 3-1/2" axle Kit #642H 4" axle Kit #644H 68DK0291	4	4067	9/16"x4"x12-1/2" U-Bolt	98224761 FOX 2.0 Dual Rear Gas Shock (2 req'd)	1 2 4 5
	2	55750	Front 5500 Shock	STABILIZERS	
	2	55761	Rear 5500 Shock	55424 Single 5500 Steering Stabilizer or	
	1	032601	Front 6" Coils Springs	95424 Dual 9500 Steering Stabilizer	
	1	012802	Control Arm Box Kit	55357 Dual Steering Stabilizer Mount	
6" Front / 5" Rear Long Arm Kit Front Coils & Brackets Rear Leaf Spring 3-1/2" axle Kit #688H 4" axle Kit #689H 43DK3272	1	012801	Control Arm Mounts	55416 Dual 5500 Steering Stabilizer (2 req'd) or	1 2 4 5
	1	012602	Front 6" Box Kit	95416 Dual 9500 Steering Stabilizer (2 req'd)	
	1	012408	Rear Block Kit for 3-1/2" axle or	T-CASE/DRIVELINE MODIFICATION	
	1	012405	Rear Block Kit for 4" axle	122501 Carrier Bearing Drop Kit	
	2	55750	Front 5500 Shock	122605 T-Case Drop Bracket - 6" kit - Manual	
8" Front / 5" Rear Long Arm Kit Front Coils & Brackets Rear Block Kit 3-1/2" axle 4" axle 27DK6432	2	55761	Rear 5500 Shock	122606 T-Case Drop Bracket - 6" kit - Auto	1 2 4 5
	1	032601	Front 6" Coil Springs	122801 T-Case Indexing Ring Kit - Auto	
	1	012802	Control Arm Box Kit	(included in 8" long arm kits)	
	1	012801	Control Arm Mounts	122802 T-Case Indexing Ring Kit - Manual	
	1	012602	Front 6" Box Kit	TRACTION BARS	
8" Front / 5" Rear Long Arm Kit Front Coils & Brackets Rear Leaf Spring 3-1/2" axle 4" axle 87DK9013	4	4064	9/16"x3-1/2"x12-1/2" U-Bolt or	122619 3.5" Axle Traction Bar Kit	1 2 4 5
	4	4067	9/16"x4"x12-1/2" U-Bolt	122618 4" Axle Traction Bar Kit	
	2	55750	Front 5500 Shock	ACCESSORIES	
	2	55761	Rear 5500 Shock	102001 Front SS Brake Lines (pr.)	
	1	032601	Front 6" Coils Springs	102009 Rear SS Brake Line	
8" Front / 5" Rear Long Arm Kit Front Coils & Brackets Rear Leaf Spring 3-1/2" axle 4" axle 87DK9013	1	012201	2" Front Spacer Kit	122315 HD Adjustable Track Bar	1 2 4 5
	1	012801	Control Arm Mounts		
	1	012802	Control Arm Box Kit		
	1	012804	Front 8" Box Kit		
	1	122801	T-Case Indexing Kit - Auto		



Notes

1. Measure rear axle tube before ordering. Some models with dual overloads will require 4068.
2. Rear lift options will not fit dually applications.
3. Not recommended for Power Wagon applications.
4. Power Wagon applications require sway bar link kit #122401. The Power Wagon has a 2" taller ride height, so net lift gain will be 4".
5. If driveline vibration occurs, order transfer case index kit #122801 or 122802.

DODGE

FORD

JEEP

SUZUKI

TOYOTA

POSI-LOK

SHOCKS/
STEERING
STABILIZERS

APPAREL/
PROMOTIONAL

PRODUCT
SPECS

VEHICLE
SPECS

2003-2007 DODGE RAM 2500 & 3500 4WD TRUCK - DIESEL

PRO-RIDE SYSTEM

2003-2007 DODGE RAM 2500 & 3500 DIESEL 4WD TRUCK (INCLUDING MEGA CAB)

Lift & Method	Qty	Part#	Description	Recommended Accessories	Notes
2" Front/ 0" Rear Front Coil Spacers Kit #223H <i>09DK153</i>	1 2 2	012201 55700 55759	2" Front Spacer Kit Front 5500 Shock Rear 5500 Shock	98224700 FOX 2.0 Front Gas Shock (2 req'd) 98224759 FOX 2.0 Rear Gas Shock (2 req'd) 55424 Single Steering Stabilizer 122315 Adjustable Track Bar (Included in 690/691H) 122618 4" Traction Bar Kit 122619 3.5" Traction Bar Kit 102001 Front SS Brake Lines (pr)	
3" Front / 2" Rear Front Coil Spacers Rear Block Kit 3-1/2" Axle Kit #224H 4" Axle Kit #264H <i>77DK707</i>	1 1 1 2 2	012303 012208 012207 55700 55759	3" Front Box Kit 2" Rear Block Kit for 3-1/2" axle or 2" Rear Block Kit for 4" axle or Front 5500 Shock Rear 5500 Shock		1 2
3" Front / 2" Rear Progressive Coil Springs Rear Block Kit 4" Axle Kit #690H 3.5" Axle Kit #691H <i>50DK0031</i>	1 1 1 2 2	032301 012304 012207 012208 55700 55759	3" Progressive Rate Coil (pr.) Front Box Kit Rear Kit for 4" Axle or Rear Kit for 3.5 Axle Front 5500 Shock Rear 5500 Shock		
6" Front / 4" Rear Standard Kit Front Coils & Bracket Kit Rear Block Kit 3-1/2" Axle Kit #234H 4" Axle Kit #265H <i>61DK5031</i>	1 1 1 2 2	032503 012611 012408 012405 55750 55761	Front Coil Springs Front Box Kit Rear Block Kit for 3-1/2" axle or Rear Block Kit for 4" axle or Front 5500 Shock Rear 5500 Shock	SHOCKS 98224750 FOX 2.0 Front Gas Shock - 6" kit (2 req'd) 98224751 FOX 2.0 Front Gas Shock - 8" kit (2 req'd) 98224759 FOX 2.0 Rear Gas Shock - 6-8" kit (2 req'd) 122604 Dual Auxiliary Hoop Mount (short arm only) or 122614 Dual Auxiliary Hoop Mount (long arm only) 55920 Dual 5500 Front Shock (4 req'd) or 98224920 FOX 2.0 Dual Front Gas Shock (4 req'd) 122009 Dual Rear Shock Mount 55761 Dual 5500 Rear Shock (2 req'd) or 98224761 FOX 2.0 Dual Rear Gas Shock (2 req'd)	1 2 3 4 5
6" Front / 5" Rear Standard Kit Front Coils & Bracket Kit Rear Leaf Springs 3-1/2" Axle Kit #236H 4" Axle Kit #266H <i>46DK7012</i>	1 1 2 4 4 2 2	032503 012611 002508 4064 4067 55750 55761	Front Coil Springs Front Box Kit Rear Leaf Springs 9/16 x 3-1/2 x 12-1/2" U-Bolt or 9/16 x 4 x 12-1/2" U-Bolt or Front 5500 Shock Rear 5500 Shock	STABILIZERS 55424 Single 5500 Steering Stabilizer or 95424 Dual 9500 Steering Stabilizer 55357 Dual Steering Stabilizer Mount 55416 Dual 5500 Steering Stabilizer (2 req'd) or 95416 Dual 9500 Steering Stabilizer (2 req'd)	1 2 3 5
6" Front /4" Rear Long Arm Kit Front Coils & Brackets Rear Block Kit 3-1/2" Axle Kit # 645H 4" Axle Kit # 647H <i>61DK6091</i>	1 1 1 1 1 2 2	032503 012802 012801 012603 012408 012405 55750 55761	Front Coils Springs Control Arm Box Kit Control Arm Mounts Front 6" Box Kit Rear Block Kit for 3-1/2" Axle or Rear Block Kit for 4" Axle or Front 5500 Shock Rear 5500 Shock	T-CASE/DRIVELINE MODIFICATION 122501 Carrier Bearing Drop Kit 122605 T-Case Drop Bracket - 6" kit - Manual 122606 T-Case Drop Bracket - 6" kit - Auto 122801 T-Case Indexing Ring Kit - Auto (included in 8" long arm kits) 122802 T-Case Indexing Ring Kit - Manual	
6" Front /4" Rear Long Arm Kit Front Coils & Brackets Rear Leaf Springs 3-1/2" Axle Kit # 648H 4" Axle Kit # 650H <i>46DK8072</i>	1 1 1 1 2 4 4 2	032503 012802 012801 012603 002508 4064 4067 55750 55761	Front Coils Springs Control Arm Box Kit Control Arm Mounts Front 6" Box Kit Rear Leaf Springs 9/16 x 3-1/2 x 12-1/2" U-Bolt or 9/16 x 4 x 12-1/2" U-Bolt or Front 5500 Shock Rear 5500 Shock	TRACTION BARS 122619 3.5" Axle Traction Bar Kit 122618 4" Axle Traction Bar Kit	
8" Front / 5" Rear Long Arm Kit Front Coils & Brackets Rear Block Kit 3-1/2" Axle Kit # 651H 4" Axle Kit # 653H <i>30DK4512</i>	1 1 1 1 1 1 2 2	032801 012801 012802 012805 122801 012518 012516 55751 55761	Front Coils Springs Control Arm Mounts Control Arm Box Kit Front 8" Box Kit T-Case Indexing Kit Rear Block Kit for 3-1/2" Axle or Rear Block Kit for 4" Axle or Front 5500 Shock Rear 5500 Shock	ACCESSORIES 102001 Front SS Brake Lines (pr.) 102009 Rear SS Brake Line 122315 HD Adjustable Track Bar	
8" Front / 5" Rear Long Arm Kit Front Coils & Brackets Rear Leaf Springs 3-1/2" Axle Kit # 654H 4" Axle Kit # 656H <i>71DK5192</i>	1 1 1 1 2 4 4 2 2	032801 012801 012802 012805 122801 002508 4064 4067 55751 55761	Front Coils Springs Control Arm Mounts Control Arm Box Kit Front 8" Box Kit T-Case Indexing Kit Rear Leaf Spring 9/16 x 3-1/2 x 12-1/2" U-Bolt or 9/16 x 4 x 12-1/2" U-Bolt or Front 5500 Shock Rear 5500 Shock	ACCESSORIES #122619 #122604 - Dual Auxiliary Front Shock Mounting Kit	

Notes

- This truck is available with two different axle sizes, 3.5" or 4". Measure rear axle tube before ordering. Some 4" axle models with dual overloads will require u-bolt 4068.
- Will not fit dually applications.
- Although unusual, if driveline vibration occurs, order transfer case drop kit available in options or t-case index kit. #122801 is included in 8" kits, substitute #122802 for manual transmission.
- Optional transfer case drop kits fit automatic transmission models only.
- Exhaust modification will be required for dual rear shock kit 122009 on 6.7L Diesel models.

2003-2007 DODGE RAM 2500 & 3500 4WD TRUCK - GAS

PRO-RIDE SYSTEM

CHEVROLET/
GMC

DODGE

FORD

JEEP

SUZUKI

TOYOTA

POSI-LOK



SHOCKS/
STEERING
STABILIZERS

APPAREL/
PROMOTIONAL

PRODUCT
SPECS

VEHICLE
SPECS

2003-2007 DODGE RAM 2500 & 3500 4WD TRUCK - GAS • 2006-2007 DODGE RAM 1500 MEGA-CAB 4WD TRUCK

Lift & Method	Qty	Part#	Description	Recommended Accessories	Notes
2" Front/ 0" Rear Front Coil Spacers Kit #223H 09DK153	1	012201	2" Front Spacer Kit	98224700 FOX 2.0 Front Gas Shock (2 req'd)	5
	2	55700	Front 5500 Shock	98224759 FOX 2.0 Rear Gas Shock (2 req'd)	
	2	55759	Rear 5500 Shock	55424 Single Steering Stabilizer	
3" Front / 2" Rear Front Coil Spacers Rear Block Kit 3-1/2" axle Kit #224H 4" axle Kit #264H 77DK707	1	012303	3" Front Box Kit	122315 Adjustable Track Bar (Included in 690/691H)	1
	1	012208	2" Rear Block Kit for 3-1/2" axle or	122618 4" Traction Bar Kit	5
	1	012207	2" Rear Block Kit for 4" axle or	122619 3.5" Traction Bar Kit	
	2	55700	Front 5500 Shock	102001 Front SS Brake Lines (pr)	
	2	55759	Rear 5500 Shock		
ACCESSORIES					
					
#102001					
6" Front/ 4" Rear Standard Kit Front Coils & Bracket Kit Rear Block Kit 3-1/2" axle Kit #226H 4" axle Kit #269H 68DK9131	1	032601	Front Coil Springs	SHOCKS	1
	1	012611	Front Box Kit	98224750 FOX 2.0 Front Gas Shock - 6" kit (2 req'd)	2
	1	012408	Rear Block Kit for 3-1/2" Axle or	98224751 FOX 2.0 Front Gas Shock - 8" kit (2 req'd)	3
	1	012405	Rear Block Kit for 4" Axle or	98224759 FOX 2.0 Rear Gas Shock - 6-8" kit (2 req'd)	4
	2	55750	Front 5500 Shock	122604 Dual Auxiliary Hoop Mount (short arm only) or	6
	2	55761	Rear 5500 Shock	122614 Dual Auxiliary Hoop Mount (long arm only)	
				55920 Dual 5500 Front Shock (4 req'd) or	
6" Front/ 5" Rear Standard Kit Front Coils & Bracket Kit Rear Leaf Springs 3-1/2" axle Kit #228H 4" axle Kit #270H 43DK2212	1	032601	Front Coil Springs	98224920 FOX 2.0 Dual Front Gas Shock (4 req'd)	
	1	012611	Front Box Kit	122009 Dual Rear Shock Mount	
	2	002508	Rear Leaf Spring	55761 Dual 5500 Rear Shock (2 req'd) or	
	4	4064	9/16 x 3-1/2 x 12-1/2" U-Bolt or	98224761 FOX 2.0 Dual Rear Gas Shock (2 req'd)	
	4	4067	9/16 x 4 x 12-1/2" U-Bolt or		
	2	55750	Front 5500 Shock	STABILIZERS	
	2	55761	Rear 5500 Shock	55424 Single 5500 Steering Stabilizer or	
				95424 Dual 9500 Steering Stabilizer	
6" Front /4" Rear Long Arm Kit Front Coils & Brackets Rear Block Kit 3-1/2" axle Kit # 657H 4" axle Kit # 659H 68DK0291	1	032601	Front Coils Springs	55357 Dual Steering Stabilizer Mount	1
	1	012802	Control Arm Box Kit	55416 Dual 5500 Steering Stabilizer (2 req'd) or	2
	1	012801	Control Arm Mounts	95416 Dual 9500 Steering Stabilizer (2 req'd)	3
	1	012603	Front 6" Box Kit		6
	1	012408	Rear Block Kit for 3-1/2" Axle or	T-CASE/DRIVELINE MODIFICATION	
	1	012405	Rear Block Kit for 4" Axle or	122501 Carrier Bearing Drop Kit	
	2	55750	Front 5500 Shock	122605 T-Case Drop Bracket - 6" kit - Manual	
	2	55761	Rear 5500 Shock	122606 T-Case Drop Bracket - 6" kit - Auto	
				122801 T-Case Indexing Ring Kit - Auto	
				(included in 8" long arm kits)	
				122802 T-Case Indexing Ring Kit - Manual	
6" Front /4" Rear Long Arm Kit Front Coils & Brackets Rear Leaf Spring 3-1/2" axle Kit # 660H 4" axle Kit # 662H 43DK3272	1	032601	Front Coils Springs	TRACTION BARS	
	1	012802	Control Arm Box Kit	122619 3.5" Axle Traction Bar Kit	
	1	012801	Control Arm Mounts	122618 4" Axle Traction Bar Kit	
	1	012603	Front 6" Box Kit	ACCESSORIES	
	2	002508	Rear Leaf Spring	102001 Front SS Brake Lines (pr.)	
	4	4064	9/16 x 3-1/2 x 12-1/2" U-Bolt or	102009 Rear SS Brake Line	
	4	4067	9/16 x 4 x 12-1/2" U-Bolt or	122315 HD Adjustable Track Bar	
	2	55750	Front 5500 Shock		
	2	55761	Rear 5500 Shock		
8" Front / 5" Rear Long Arm Kit Front Coils & Brackets Rear Block Kit 3-1/2" axle 4" axle 27DK6432	1	032801	Front Coils Springs	ACCESSORIES  #122801 - T-Case Indexing Ring Kit	
	1	012201	2" Front Spacer Kit		
	1	012801	Control Arm Mounts		
	1	012802	Control Arm Box Kit		
	1	012805	Front 8" Box Kit		
	1	122801	T-Case Indexing Kit - Auto		
	1	012518	Rear Block Kit for 3-1/2" Axle or		
	1	012516	Rear Block Kit for 4" Axle		
	2	55751	Front 5500 Shock		
	2	55761	Rear 5500 Shock		
8" Front / 5" Rear Long Arm Kit Front Coils & Brackets Rear Leaf Spring 3-1/2" axle 4" axle 87DK9013	1	032801	Front Coil Springs	ACCESSORIES  #122801 - T-Case Indexing Ring Kit	
	1	012201	2" Front Spacer Kit		
	1	012801	Control Arm Mounts		
	1	012802	Control Arm Box Kit		
	1	012805	Front 8" Box Kit		
	1	122801	T-Case Indexing Kit - Auto		
	2	002508	Rear Leaf Spring		
	4	4064	9/16"x4"x12-1/2" U-Bolt or		
	4	4067	9/16"x4"x12-1/2" U-Bolt or		
	2	55751	Front 5500 Shock		
	2	55761	Rear 5500 Shock		

- Notes
1. This truck is available with two different axle sizes, 3.5" or 4". Measure rear axle tube before ordering. Some 4" axle models with dual overloads will require u-bolt 4066.
 2. Rear lift options will not fit dually applications.
 3. Although unusual, if driveline vibration occurs, order transfer case drop kit available in options or t-case index kit.
 4. Optional transfer case drop kits fit automatic transmission models only.
 5. Not recommended for Power Wagon applications.
 6. Power Wagon applications require sway bar link kit #122401.
The Power Wagon has a 2" taller ride height, so net lift gain will be either 4" or 6" (6" or 8" kit)..

2003-2014 DODGE RAM 2500 & 3500 ACCESSORIES

DODGE

FORD

JEEP

SUZUKI

TOYOTA

POSI-LOK

SHOCKS/
STEERING
STABILIZERS

APPAREL/
PROMOTIONAL

PRODUCT
SPECS

VEHICLE
SPECS



part shown in gray - available in black only

Multi-Shock Bracket Kits 2003-2013 4-Link Trucks

- Front - Short Arm
#122604.....58DK435
- Front - Long Arm
#122614.....46DK725
- Rear*
#122009.....06DK78
- Front - Short Arm
#122615.....77DK624

*exhaust modification required on 6.7L diesels



Traction Bars (2003-2014)

- 3-1/2" Axle
#122619.....85DK665
- 4" Axle
#122618.....85DK665



#55370/55422
Shown

Steering Stabilizer Kits Single and Dual

2003-2008 w/ Inverted 'Y' Steering*

Bracket	Stabilizer (ea)	Description
n/a	55424	Single 5500 Kit
n/a	95424	Single 9500 Kit
55357	55416	Dual 5500 Kit
55357	95416	Dual 9500 Kit

2008-2013 OE 4-Link Trucks w/ Inverted 'T' Steering*

Bracket	Stabilizer (ea)	Description
n/a	55422	Single 5500 Kit
n/a	95422	Single 9500 Kit
55369	55422	Dual 5500 Kit
55369	95422	Dual 9500 Kit

2013-2014 OE Radius Arm Trucks

Bracket	Stabilizer (ea)	Description
n/a	55427	Single 5500 Kit
n/a	95427	Single 9500 Kit
n/a	98224018	Single FOX 2.0 Kit
55370	55422	Dual 5500 Kit
55370	95422	Dual 9500 Kit
55370	98224016	Dual FOX 2.0 Kit

*Late 2008 models were supplied with the newer inverted 'T' steering linkage that match the 2009-13 models



Front Brake Lines

- 2013-2014 - Radius Arm Trucks
#102003.....95DK751
- 2003-2013
#102001.....14DK351



Rear Brake Lines

- 2003-2011
#102009.....15DK37



Adjustable Front Track Bar

- 2013-2014 (Radius Arm Trucks)
#122314.....58DK923
- 2003-2013 (4-Link Trucks)
#122315.....58DK923



Long Arm Upgrade Kit

- 2003-2013 OE 4-Link Trucks
- Works with 6" - 8" of lift
- Complete upgrade with frame brackets, heavy-duty arms, bushings and hardware
- No cutting of factory brackets required
- #012801/012802.....82DK339



T-Case Indexing Ring

- Allows driveshaft installation without interference.
- 2003-2013 OE 4-Link Trucks
- Automatic Transmission
#122801.....75DK512
- Manual Transmission
#122802.....30DK242



Carrier Bearing Drop Kit

- 2003-2013 OE 4-Link Trucks
#122501.....07DK92
- 2013-2014 OE Radius Arm Trucks
#122405.....16DK15

2013-2013 OE Radius Arm Trucks

- Works with 4" - 8" of lift
- Converts factory radius arm to 4-link for better handling and control
- Complete upgrade with frame brackets, heavy-duty arms, bushings and hardware
- #012403/122404.....25DK309



Short Arm Control Arms

- 2003-2013 4-Link Trucks
- Works with 2"-3" of lift
- Includes upper/lower arms, bushings and grease fittings
- #122322.....78DK363

2000-2002 DODGE RAM 2500 & 3500 4WD TRUCK

PRO-RIDE SYSTEM

CHEVROLET/
GMC

DODGE

FORD

JEEP

SUZUKI

TOYOTA

POSI-LOK

SHOCKS/
STEERING
STABILIZERS

APPAREL/
PROMOTIONAL

PRODUCT
SPECS

VEHICLE
SPECS



#208H - 3" Lift Kit



#122305 - Upper & Lower Control Arm Kit

2000-2002 DODGE RAM 2500 & 3500 4WD TRUCK - GAS & DIESEL

Lift & Method	Qty	Part#	Description	Recommended Accessories	Notes
2" Front / 0" Rear	1	012201	Front Spacer Kit	98224700	
Front Coil Spacers	2	55710	Front 5500 Shock <i>or</i>	98224710	
<8800 GVW Kit #204H	2	55700	Front 5500 Shock (For 8800# GVW)	98224750	
8800 GVW Kit #205H	2	55719	Rear 5500 Shock	98224719	
<i>09DK153</i>				122301	
3" Front / 1" Rear	1	012302	Front 3" Spacer Kit	55620	Front Dual Shock Bracket Kit
Front Coil Spacers	1	012109	1" Block & U-Bolt Kit	55650	Dual 5500 Shock - 2" Kit (2 req'd)
Rear Block Kit	2	55750	Front 5500 Shock	98224650	Dual 5500 Shock - 3" Kit (2 req'd) <i>or</i>
Kit # 208H	2	55719	Rear 5500 Shock	55406	FOX 2.0 Front Gas Shock - 3" Kit (2 req'd)
<i>47DK115</i>				55351	Single Steering Stabilizer
3" Front / 1" Rear	1	012302	Front 3" Spacer Kit	55404	Dual Steering Stabilizer Bracket
Front Coil Spacers	1	113208	Rear Add-A-Leaf	55404	Dual 5500 Steering Stabilizer (2 req'd) <i>or</i>
Rear Add-A-Leaf	4	4049	9/16 x 3-1/8 x 15" Sq U-Bolt	95404	Dual 9500 Steering Stabilizer (2 req'd)
Kit #209H	2	55750	Front 5500 Shock	122305	Upper & Lower Control Arm Kit
<i>55DK755</i>	2	55719	Rear 5500 Shock	PSL400	4x4 Posi-Lok™ (page 119)

5" Kits Continued ▶

See Notes ▶



Vehicle Specs:
5" Long Arm System
37x13.50x17 Dick Cepek FC II
17x9 Classic II Wheels

2000-2002 DODGE RAM 2500 & 3500 4WD TRUCK

PRO-RIDE SYSTEM

DODGE

FORD

JEEP

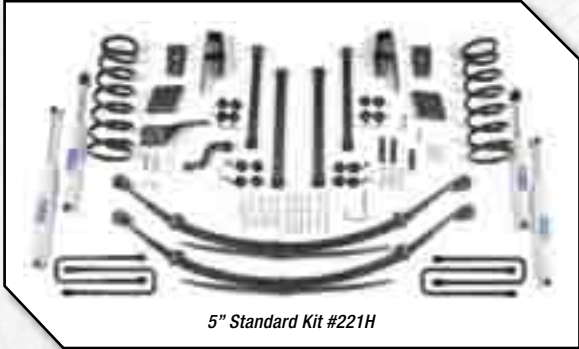

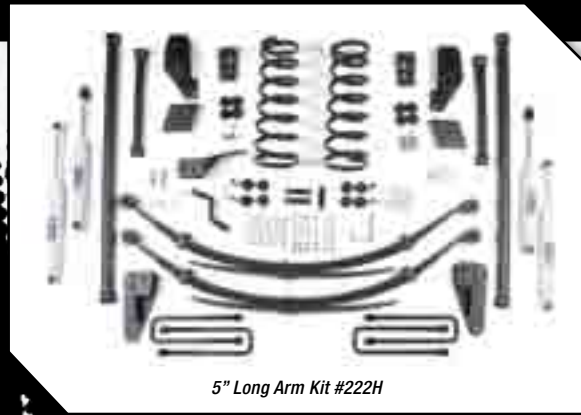

5" Standard Kit #221H



5" Long Arm Kit #222H

2000-2002 DODGE RAM 2500 & 3500 4WD TRUCK - GAS & DIESEL (CONTINUED)

Lift & Method	Qty	Part#	Description	Recommended Accessories	Notes	
5" Front / 4.5" Rear Standard Kit	1	032503	Front Coil Springs	98224750	1 2	
	1	012504	Front Box Kit	98224761		
	1	012456	Front Coils & Brackets	122303		
	1	012457	Rear Blocks & Add-A-Leaves	55650		
	1	012457	2" Block & Add-A-Leaf Kit w/o top mounted overload or 2" Block & Add-A-Leaf Kit with top mounted overload	98224650		
w/o top ovid Kit #217H with top ovid Kit #218H 48DK3151	1	55406	Single Steering Stabilizer	PSL400	4x4 Posi-Lok™ (page 119)	
	2	55750	Front 5500 Shock	55351		Dual Steering Stabilizer Mounting Kit
	2	55761	Rear 5500 Shock	55404		Dual Steering Stabilizer Shock (2 req'd) or 95404 Dual 9500 Steering Stabilizer (2 req'd)
5" Front / 4.5" Rear Long Arm Kit	1	032503	Front Coil Springs	122501	1 2 3	
	1	012511	Long Arm Kit - box 1 of 2	122008		
	1	012512	Long Arm Kit - box 2 of 2	122802		
	1	012456	Rear Blocks & Add-A-Leaves			
	1	012457	2" Block & Add-A-Leaf Kit w/o top mounted overload or 2" Block & Add-A-Leaf Kit with top mounted overload			
w/o top ovid Kit #219H with top ovid Kit #220H 78DK0681	1	55406	Single Steering Stabilizer			
	2	55750	Front 5500 Shock			
	2	55761	Rear 5500 Shock			
5" Front / 4.5" Rear Standard Kit	1	032503	Front Coil Springs			
	1	012504	Front Box Kit			
	2	002458	Rear Leaf Spring			
	1	012508	Rear Leaf Springs			
	1	55406	Rear Box Kit			
Kit #221H 63DK2971	2	55750	Front 5500 Shock			
	2	55761	Rear 5500 Shock			
5" Front / 4.5" Rear Long Arm Kit	1	032503	Front Coil Springs			
	1	012511	Long Arm Kit - box 1 of 2			
	1	012512	Long Arm Kit - box 2 of 2			
	2	002458	Rear Leaf Spring			
	1	012508	Rear Box Kit			
Kit #222H 93DK9312	1	55406	Single Steering Stabilizer			
	2	55750	Front 5500 Shock			
	2	55761	Rear 5500 Shock			

Notes

1. Dual stabilizer may be used in place of single stabilizer. Dual stabilizer only fits 3-1/4" axle tube diameter.
2. May require exhaust modification.
3. #002458 rear springs come with OE style bushings installed.

'94-'01 Dodge 1500 Long Arm Upgrade Kit '94-'02 Dodge 2500 Long Arm Upgrade Kit

- Upgrade your existing 6" kit to a long arm
- Fits all Dodge '94-01 1/2 Ton & '94-'02 3/4 Ton 4WD with 5"-6" of lift
- Kit includes longer lower links—greaseable, frame mount brackets, lower arm bushing/sleeve kit

#122505..... 37DK294

ACCESSORIES



#PSL400
1994-2001 Ram 1500 w/ Dana 44-60
1994-2002 Ram 2500, 3500 w/ Dana 44-60



#122505

1994-1999 DODGE RAM 2500 & 3500 4WD TRUCK

PRO-RIDE SYSTEM

CHEVROLET/
GMC

DODGE

FORD

JEEP

SUZUKI

TOYOTA

POSI-LOK

SHOCKS/
STEERING
STABILIZERS

APPAREL/
PROMOTIONAL

PRODUCT
SPECS

VEHICLE
SPECS

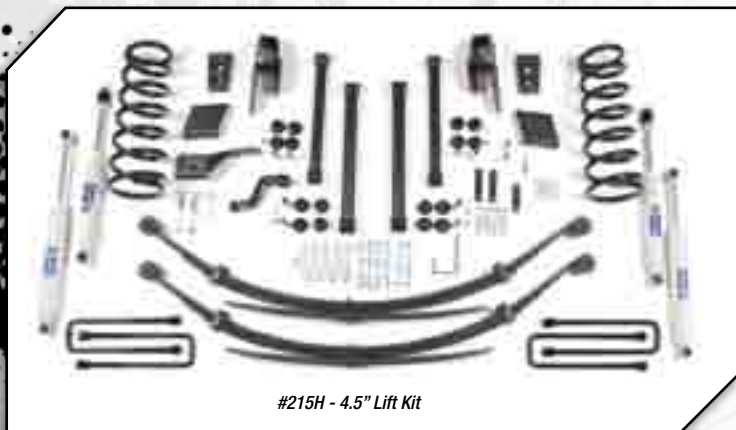

#215H - 4.5" Lift Kit

4.5" Kit Features

- ProRide coils to improve ride quality
- Heavy duty control arms to reposition front axle
- Track bar bracket to recenter front axle
- Forged pitman arm to correct steering
- Sway bar and bump stop relocation
- Rear block & AAL kit or replacement GlideRide springs
- BDS-5500 or Fox 2.0 Shocks

1994-1999 DODGE RAM 2500 & 3500 4WD TRUCK - GAS & DIESEL

Lift & Method	Qty	Part#	Description	Recommended Accessories	Notes
2" Front / 0" Rear Front Coil Spacers <8800 GVW Kit #204H 8800 GVW Kit #205H 09DK153	1	012201	Front Spacer Kit	98224700 FOX 2.0 Front Gas Shock - 2" Kit (2 req'd)	
	2	55710	Front 5500 hock or	98224750 FOX 2.0 Front Gas Shock - 3" Kit (2 req'd)	
	2	55700	Front 5500 Shock (For 8800# GVW)	98224719 FOX 2.0 Rear Gas Shock - 0-1" Kit (2 req'd)	
	2	55719	Rear 5500 Shock	122301 Front Dual Shock Bracket Kit	
3" Front / 1" Rear Front Coil Spacers Rear Block Kit Kit #208H 47DK115	1	012302	Front 3" Spacer Kit	55620 Dual 5500 Shock - 2" Kit (2 req'd)	
	1	012109	1" Block & U-Bolt Kit	55650 Dual 5500 Shock - 3" Kit (2 req'd) or	
	2	55750	Front 5500 Shock	98224650 FOX 2.0 Front Gas Shock - 3" Kit (2 req'd)	
	2	55719	Rear 5500 Shock	55406 Single Steering Stabilizer	
3" Front / 1" Rear Front Coil Spacers Rear Add-A-Leaf Kit #209H 55DK755	1	012302	Front 3" Spacer Kit	55351 Dual Steering Stabilizer Bracket	
	1	113208	Rear Add-A-Leaf	55404 Dual 5500 Steering Stabilizer (2 req'd) or	
	4	4049	9/16 x 3-1/8 x 15" Sq U-Bolt	95404 Dual 9500 Steering Stabilizer (2 req'd)	
	2	55750	Front 5500 Shock	122305 Upper & Lower Control Arm Kit	
	2	55719	Rear 5500 Shock	PSL400 4x4 Posi-Lok™ (page 119)	
4.5" Front / 4.5" Rear Standard Kit Front Coils & Brackets Rear Blocks & Add-A-Leafs w/o top ovd Kit #211H with top ovd Kit #212H 64DK2151	1	032503	Front Coil Springs	98224750 FOX 2.0 Front Gas Shock (2 req'd)	1
	1	012503	Front Box Kit	98224761 FOX 2.0 Rear Gas Shock (2 req'd)	2
	1	012456	2" Block & Add-A-Leaf Kit w/o top mounted overload or	122303 Front Dual Shock Bracket Kit	3
	1	012457	2" Block & Add-A-Leaf Kit with top mounted overload	55650 Dual 5500 Shock (2 req'd) or	
	1	55417	Single Steering Stabilizer	98224650 FOX 2.0 Dual Gas Shock (2 req'd)	
	2	55750	Front 5500 Shock	55351 Dual Steering Stabilizer Mounting Kit	
	2	55761	Rear 5500 Shock	55404 Dual Steering Stabilizer Shock (2 req'd) or	
4.5" Front / 4.5" Rear Long Arm Kit Front Coils & Brackets Rear Blocks & Add-A-Leafs w/o top ovd Kit #213H with top ovd Kit #214H 94DK9581	1	032503	Front Coil Springs	95404 Dual 9500 Steering Stabilizer (2 req'd)	
	1	012511	Long Arm Kit - box 1 of 2	122501 Carrier Bearing Drop	
	1	012513	Long Arm Kit - box 2 of 2	122008 Rear Sway Bar Inlks	
	1	012456	2" Block & Add-A-Leaf Kit w/o top mounted overload or	122802 Indexing Ring Kit	
	1	012457	2" Block & Add-A-Leaf Kit with top mounted overload	PSL400 4x4 Posi-Lok™ (page 119)	
	1	55417	Single Steering Stabilizer		
	2	55750	Front 5500 Shock		
	2	55761	Rear 5500 Shock		
4.5" Front / 4.5" Rear Standard Kit Front Coils & Brackets Rear Leaf Springs Kit #215H 89DK0971	1	032503	Front Coil Springs		1
	1	012503	Front Box Kit		2
	2	002458	Rear Leaf Spring		3
	1	012508	Rear Box Kit		
	1	55417	Single Steering Stabilizer		
	2	55750	Front 5500 Shock		
	2	55761	Rear 5500 Shock		
4.5" Front / 4.5" Rear Long Arm Kit Front Coils & Brackets Rear Leaf Springs Kit #216H 10DK8312	1	032503	Front Coil Springs		
	1	012511	Long Arm Kit - box 1 of 2		
	1	012513	Long Arm Kit - box 2 of 2		
	2	002458	Rear Leaf Spring		
	1	012508	Rear Box Kit		
	1	55417	Single Steering Stabilizer		
	2	55750	Front 5500 Shock		
	2	55761	Rear 5500 Shock		



Notes

1. For models built after February 9, 1994 due to track bar stud size.
2. Dual stabilizer may be used in place of single steering stabilizer. Dual stabilizer only fits 3-1/4" diameter axle tubes.
3. May require exhaust modification.

1969-1993 DODGE RAM 1500 & 2500 4WD TRUCK

GLIDE-RIDE SYSTEM

DODGE

FORD

JEEP

SUZUKI

TOYOTA

- 5" Glide-Ride leaf springs
- Front box kit includes: new urethane bushings, sleeves, zinc plated u-bolts with nuts and washers, and brake line relocation brackets
- Glide-Ride leaf springs include tapered ends with anti-friction pads on both front and rear springs.
- Steering block restores steering linkage angles.



5" Glide-Ride Suspension System With Rear Springs

1974 1/2 - 1993 DODGE RAM 1500 & 2500 4WD TRUCK

Lift & Method	Qty	Part#	Description	Recommended Accessories	Notes	
5" Front / 5" Rear	2	002501	Front Leaf Spring	98224650	FOX 2.0 Front Gas Shock (2 req'd)	1
Front Leaf Springs	1	012502	Front Box Kit	98224760	FOX 2.0 Rear Gas Shock (2 req'd)	2
Rear Blocks & Add-A-Leafs	1	012409	Rear Block Kit	55310	Single Steering Stabilizer Bracket Kit	3
Kit #202H	1	119158	Rear Add-A-Leaf	55403	Single Steering Stabilizer Shock	4
<i>08DK928</i>	1	082501	3" Steering Block	55361	Dual Steering Stabilizer Bracket Kit	5
	2	55650	Front 5500 Shock	55402	Dual 5500 Steering Stabilizer Shock (2 req'd)	6
	2	55760	Rear 5500 Shock	PSL450	4x4 Posi-Lok™ (page 119)	
5" Front / 5" Rear	2	002501	Front Leaf Spring			
Front Leaf Springs	1	012502	Front Box Kit			
Rear Leaf Springs	2	002509	Rear Leaf Spring			
Kit #203H	1	012507	Rear Box Kit			
<i>68DK6621</i>	1	082501	3" Steering Block			
	2	55650	Front 5500 Shock			
	2	55760	Rear 5500 Shock			



1969-1974 DODGE RAM 1500 & 2500 4WD TRUCK

Lift & Method	Qty	Part#	Description	Recommended Accessories	Notes	
5" Front / 5" Rear	2	002501	Front Leaf Spring	98224650	FOX 2.0 Front Gas Shock (2 req'd)	1
Front Leaf Springs	1	012501	Front Box Kit	98224760	FOX 2.0 Rear Gas Shock (2 req'd)	2
Rear Blocks & Add-A-Leafs	1	012409	Rear Block Kit	55310	Single Steering Stabilizer Bracket Kit	4
Kit #200H	1	119158	Rear Add-A-Leaf	55403	Single Steering Stabilizer Shock	5
<i>73DK228</i>	1	082501	3" Steering Block	55361	Dual Steering Stabilizer Bracket Kit	6
	2	55650	Front 5500 Shock	55402	Dual 5500 Steering Stabilizer Shock (2 req'd)	
	2	55760	Rear 5500 Shock	PSL450	4x4 Posi-Lok™ (page 119)	
5" Front / 5" Rear	2	002501	Front Leaf Spring			
Front Leaf Springs	1	012501	Front Box Kit			
Rear Leaf Springs	2	002509	Rear Leaf Spring			
Kit #201H	1	012507	Rear Box Kit			
<i>34DK9521</i>	1	082501	3" Steering Block			
	2	55650	Front 5500 Shock			
	2	55760	Rear 5500 Shock			

ACCESSORIES



#PSL450

Notes

1. On models with Saginaw or Corporate type front driveshaft, CV cluster may require dressing to prevent binding.
2. Anti-Sway bar links will have to be sectioned and lengthened.
3. On models equipped with 4WD dash light, wiring will need to be lengthened.
4. Not for heavy duty 3/4 ton.
5. I.D. of bushing is smaller than mounting pin and will require lubrication and extra effort for installation.
6. #082501 steering block only fits Dana 44 with 3 bolt knuckle.

Vehicle Specs:
5" Lift Kit
35" M/T Claws
15" Steel Wheels



FORD



FORD RANGER & BRONCO II 4WD PRO-RIDE SYSTEM

***WILL ALSO WORK ON 1994-97 MAZDA TRUCK**



4" & 6" Kit Features

- Pro-Ride Coil Springs in 4" and 6" heights over stock
- Radius arm drop, axle pivot, bump stop relocation, and anti-sway bar drop brackets included
- Pitman arm (PS) included in box kit to correct steering linkage angles
- Blocks & Add-A-Leafs included in box kit to increase load carrying capacity

1983-1997 FORD RANGER 4WD W/ POWER STEERING • 1982-91 FORD BRONCO II 4WD W/ POWER STEERING

Lift & Method	Qty	Part#	Description	Recommended Accessories	Notes	
4" Front / 3.5" Rear	1	033402	Coil Spring Kit	Page 128	Steering Stabilizers	1
Front Coil & Brackets	1	013400	Front & Rear Kit (Complete)	129101	Alignment Cam (2 req'd) <i>or</i>	2
Rear Blocks & Add-A-Leafs	2	55800	Front 5500 Shock	129102	Alignment Cam (2 req'd)	3
Ranger Kit #516H	2	55829	Rear 5500 Shock (Ranger) <i>or</i>	123401	Anti-Sway Bar Drop Kit	4
Bronco Kit #517H	2	55650	Rear 5500 Shock (Bronco II)			5
<i>01FK018</i>						
6" Front / 5.5" Rear	1	033602	Coil Spring Kit			
Front Coil & Brackets	1	013600	Front & Rear Kit (Complete)			
Rear Blocks & Add-A-Leafs	2	55820	Front 5500 Shock			
Kit #518H	2	55829	Rear 5500 Shock			
<i>60FK068</i>						

Vehicles equipped with STX 1.5" factory lift will not achieve stated height.

Notes

1. Front end alignment required. Alignment cams may be required. See page 118.
2. Extra cab models may not achieve stated lift.
3. Models equipped with 2 piece driveshaft require lowering of carrier bearing crossmember.
4. Bronco II 1985-90 models with CV joint type drive shaft must convert to exposed joint shaft.
5. Will not fit hybrid model, 2WD, or diesel models.



Vehicle Specs:
6" Lift Kit
33" TrXus MT
15" AR Baja

2014 FORD F-150 4WD HIGH CLEARANCE IFS SYSTEM

CHEVROLET/
GMC

DODGE

FORD

JEEP

SUZUKI

TOYOTA

POSI-LOK

SHOCKS/
STEERING
STABILIZERS

APPAREL/
PROMOTIONAL

PRODUCT
SPECS

VEHICLE
SPECS



#1503H - 6" kit

2.5" Upper Strut Mounts

- Top Spacer and Pre-load
- Ball Joint Protection
- 1" Rear Available



Kit #572H

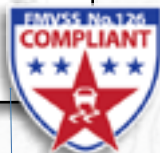

- One Piece High Clearance Crossmembers
- Off Road Protection
- Ductile Iron Steering Knuckles



Vehicle Specs:
6" Lift Kit
35" Dick Cepek A/T
18" WORX Beast

2014 FORD F-150 4WD

Lift & Method	Qty	Part#	Description	Recommended Accessories	Notes				
2.5" Front / 0" Rear Upper Strut Mount Kit #572H 66FK641	1	013250	Front Leveling Kit	013109 1" Rear Block and U-Bolt	1				
				55651 Rear 5500 Shock (2 req'd)	2				
				98224651 FOX 2.0 Rear Shock (2 req'd)					
4" Front / 2-1/2" Rear IFS w/ Strut Spacer Rear Block Kit #1502H 98FK5961	1	023622	Front Box Kit 1 of 4	98224828 FOX 2.0 Rear Gas Shock (2 req'd)	3				
				023623 Front Box Kit 2 of 4	4				
				023625 Front Box Kit 3 of 4	5				
				023626 Front Box Kit 4 of 4	6				
				023425 Front Strut Spacer/ Rear Block Box Kit	7				
				HC HIGH CLEARANCE	2	55828	Rear 5500 Shock		
6" Front / 4" Rear IFS w/ Strut Spacer Rear Block Kit #1503H 15FK6171 Fox Performance System Kit #1503F 70FK8643	1	023625	Front Box Kit 1 of 4	013429 4" Rear Block	3				
				023626 Front Box Kit 2 of 4	4				
				023622 Front Box Kit 3 of 4	5				
				023623 Front Box Kit 4 of 4	6				
				013529 Rear Box Kit	7				
				023605 Front Strut Spacer Kit or	8				
				HC HIGH CLEARANCE	1	88302144	FOX 2.5 Coilover Kit		
								2	55760 Rear 5500 Shock or
	2	98224760 FOX 2.0 Rear Gas Shock							

Notes:

1. Strut Compressor required for installation.
2. 1" Rear block kit is available in the accessories.
3. Requires frame bracket modification and welding.
4. 18" wheels with 5-5.5" total backspacing should be test fit prior to mounting tire to ensure proper clearance to BDS steering knuckle.
5. 18" or larger diameter wheels required. Stock 17" & 18" wheels cannot be reinstalled. Stock 20" wheels can be used with up to a 305/60/20 tire.
6. E-brake bracket required for factory powersteps (123018).
7. For a level to tail low appearance use #023416 with Kit#1502H or use #013429 with Kit#1503H. Block kits replace factory 1-1/4" block.
8. Models with a 2-piece rear driveshaft may require carrier bearing drop shim kit #122405

2014 FORD F-150 2WD HIGH CLEARANCE IFS SYSTEM

CHEVROLET/
GMC

DODGE

FORD

JEEP

SUZUKI

TOYOTA

POSI-LOK

SHOCKS/
STEERING
STABILIZERS

APPAREL/
PROMOTIONAL

PRODUCT
SPECS

VEHICLE
SPECS



Vehicle Specs:
6" Performance System
35" Toyo M/Ts
22x12 Fuel Mavericks

4" & 6" Kit Features

- One Piece High Clearance Crossmember
- Ductile Iron Steering Knuckles
- Upper strut mount spacers or Fox 2.5 coil-overs
- Crossmember braces for subframe rigidity
- Offset pin block kit to recenter rear axle



#1504H - 4" kit

2014 FORD F-150 2WD

Lift & Method	Qty	Part#	Description	Recommended Accessories	Notes
2.5" Front / 0" Rear Upper Strut Mounts Kit #572H 66FK641	1	013250	Front Leveling Kit	013109 1" Rear Block and U-Bolt 55651 Rear 5500 Shock (2 req'd) 98224651 FOX 2.0 Rear Shock (2 req'd)	1
4" Front / 2-1/2" Rear IFS w/ Strut Spacer	1	023625	Front Box Kit 1 of 4	98224828 FOX 2.0 Rear Gas Shock (2 req'd)	2
Rear Block	1	023626	Front Box Kit 2 of 4	023416 2" Rear Block	3
Kit #1504H 98FK5961	1	023624	Front Box Kit 3 of 4	123018 E-brake Bracket	4
	1	023425	Front Strut Spacer/ Rear Block Box Kit		
	2	55828	Rear 5500 Shock		
6" Front / 4" Rear IFS w/ Strut Spacers	1	023625	Front Box Kit 1 of 4	98224760 FOX 2.0 Rear Gas Shock (2 req'd)	2
Rear Block	1	023626	Front Box Kit 2 of 4	013429 4" Rear Block	3
Kit #1505H	1	023624	Front Box Kit 3 of 4	123018 E-brake Bracket	4
Fox Performance System	1	013529	Rear Box Kit	123405 Carrier Bearing Drop Kit	5
Kit #1505F	1	023605 or	Front Strut Spacer Kit or	123609 Rear Drive Shaft Spacer	
70FK8643	1	88302114	FOX 2.5 Coilover Kit		
	2	55760 or	Rear 5500 Shock or		
	2	98224760	FOX 2.0 Rear Gas Shock		

Notes

1. Strut compressor required for installation.
2. 18" or larger diameter wheels required. Stock 17" & 18" wheels cannot be reinstalled. Stock 20" wheels can be used with up to a 305/60-20 tires.
3. E-brake bracket required for factory powersteps (123018)
4. For a level to tail low appearance use #023415 with Kit#1504H or use #013429 with Kit#1505H. Block kits replace factory 1-1/4" block.
5. Models with a 2-piece rear driveshaft may require carrier bearing drop shim kit #122405

2.5" Upper Strut Mounts

- Top Spacer and Pre-load
- Ball Joint Protection
- 1" Rear Available

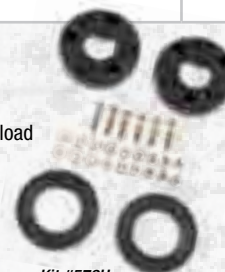

Kit #572H

2009-2013 FORD F-150 4WD HIGH CLEARANCE IFS SYSTEM

CHEVROLET/
GMC

DODGE

FORD

JEEP

SUZUKI

TOYOTA

POSI-LOK

SHOCKS/
STEERING
STABILIZERS

APPAREL/
PROMOTIONAL

PRODUCT
SPECS

VEHICLE
SPECS



#573H - 6" kit

- New Gas Charged Struts Included
- One Piece High Clearance Crossmember
- Off Road Protection
- Ductile Iron Steering Knuckles



FOX PERFORMANCE
COILOVER SYSTEM



Vehicle Specs:
4" Lift Kit
35" A/T Tires
20" BMF Wheels



2009-2013 FORD F-150 4WD

Lift & Method	Qty	Part#	Description	Recommended Accessories	Notes
2.5" Front / 0" Rear Upper Strut Mounts Kit #572H 66FK641	1	013250	Front Leveling Kit	013109 1" Rear Block and U-Bolt 55651 Rear 5500 Shock (2 req'd) 98224651 FOX 2.0 Rear Shock (2 req'd)	1
4" Front / 2-1/2" Rear IFS w/ Strut Spacer Rear Block Kit #598H 98FK5961	1 1 1 1 1	023625 023626 023622 023623 023405	Front Box Kit 1 of 4 Front Box Kit 2 of 4 Front Box Kit 3 of 4 Front Box Kit 4 of 4 Front Strut Spacer/ Rear Block Box Kit	98224828 FOX 2.0 Rear Gas Shock (2 req'd) 023415 2" Rear Block 123018 E-brake Bracket	2 3 4 5 7
6" Front / 4" Rear IFS w/ Struts Rear Block Kit #573H 60FK5091 Fox Performance System Kit #573F 70FK8043	1 1 1 1 1 1 1 2	023625 023626 023622 023623 013529 98163 or 88302063 55760 or 98224760	Front Box Kit 1 of 4 Front Box Kit 2 of 4 Front Box Kit 3 of 4 Front Box Kit 4 of 4 Rear Box Kit Front Strut Kit or FOX 2.5 Coilover Kit Rear 5500 Shock or FOX 2.0 Rear Gas Shock	98224760 FOX 2.0 Rear Gas Shock (2 req'd) 013429 4" Rear Block 123018 E-brake Bracket 123405 Carrier Bearing Drop Kit 123609 Rear Drive Shaft Spacer	1 2 3 4 5 6 7



Notes

1. Strut compressor required for installation.
2. Requires frame bracket modification and welding.
3. 18" or larger diameter wheels required. Stock 17" & 18" wheels cannot be reinstalled. Stock 20" wheels can be used with up to a 305/60-20 tires.
4. E-brake bracket required for factory powersteps (123018)
5. For a level to tail low appearance use #023415 with Kit#598H or use #013429 with Kit#573H. Block kits replace factory 1-1/4" block.
6. Models with a 2-piece rear driveshaft may require carrier bearing drop shim kit #1234025
7. Early 2009 models may require brake assembly modification

Vehicle Specs:
2.5" Lift Kit
33" Toyo AT2
20" XD



2009-2013 FORD F-150 2WD

HIGH CLEARANCE IFS SYSTEM



Vehicle Specs:
6" Lift Kit
35" Toyo M/T
20" BMF F.I.T.E.



6" Kit Features

- Custom valved gas struts included
- One piece heavy duty crossmembers
- CNC machined steering knuckles
- Alignment cam bolts

2.5" Upper Strut Mounts

- Top Spacer and Pre-load
- Ball Joint Protection
- 1" Rear Available

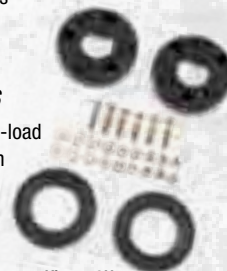

Kit #572H

2009-2013 FORD F-150 2WD

Lift & Method	Qty	Part#	Description	Recommended Accessories	Notes	
2.5" Front / 0" Rear Upper Strut Mounts Kit #572H 66FK641	1	013250	Front Leveling Kit	013109 55651 98224651	1" Rear Block and U-Bolt Rear 5500 Shock (2 req'd) FOX 2.0 Rear Gas Shock (2 req'd)	1
4" Front / 2-1/2" Rear IFS w/ Strut Spacer Rear Block Kit#599H 10FK2951	1 1 1 1	023625 023626 023624 023405	Front Box Kit 1 of 3 Front Box Kit 2 of 3 Front Box Kit 3 of 3 Front Strut Spacer/ Rear Block Kit	98224828	FOX 2.0 Rear Gas Shock (2 req'd)	2 3 4 6
6" Front / 4" Rear IFS w/ Struts Rear Block Kit# 577H 81FK1081 Fox Performance System Kit# 577F 91FK4033	1 1 1 1 1 2 2	023625 023626 023624 013529 98163 or 88302063 55760 or 98224760	Rear 5500 Shock Front Box Kit 1 of 3 Front Box Kit 2 of 3 Front Box Kit 3 of 3 Rear Box Kit Front Strut Kit or FOX 2.5 Coilover Kit Rear 5500 Shock or FOX 2.0 Rear Gas Shock	98224760 013429 122405 123609	FOX 2.0 Rear Gas Shock (2 req'd) 4" Rear Block Carrier Bearing Drop Kit Rear Drive Shaft Spacer	2 3 4 5 6

Notes

1. Strut compressor required for installation.
2. 18" or larger diameter wheels required. Stock 17" & 18" wheels cannot be reinstalled. Stock 20" wheels can be used with up to a 305/60-20 tires.
3. E-brake bracket required for factory powersteps (123018)
4. For a level to tail low appearance use #023415 with Kit#599H or use #013429 with Kit#577H. Block kits replace factory 1-1/4" block.
5. Models with a 2-piece rear driveshaft may require carrier bearing drop shim kit #1225405
6. Early 2009 models may require brake assembly modification.



2004-2008 FORD F-150 4WD

IFS SYSTEM & UPPER STRUT MOUNTS

CHEVROLET/
GMC

DODGE

FORD

JEEP

SUZUKI

TOYOTA

POSI-LOK

SHOCKS/
STEERING
STABILIZERS

APPAREL/
PROMOTIONAL

PRODUCT
SPECS

VEHICLE
SPECS



4" & 6" Kit Features

- High Clearance Crossmembers
- Differential Skid Plate Included
- Stainless Steel Brake Lines
- CNC Machined Steering Knuckles
- Rear Leaf Spring Option
- Upper Strut Spacers



Vehicle Specs:
6" Lift Kit
35" M/T ATZ
18" Eagle Alloy 187

2004-2008 FORD F-150 4WD WITH STRUT SPACER

Lift & Method	Part#	Description	Recommended Accessories	Notes		
2" Front / 0" Rear Upper Strut Mounts Kit #540H 54FK231	1	013200	Front Leveling Kit	55651 98224651	Rear 5500 Shock FOX 2.0 Rear Shocks (2 req'd)	5 7 8
	1	023630	Front Box Kit 1 of 4	55312	Single Stabilizer Mounting Kit	1
4" Front / 2" Rear IFS w/ Strut Spacer Rear Block Kit Kit #576H 60FK8402	1	023631	Front Box Kit 2 of 4	55402	Single 5500 Steering Stabilizer (1 Req'd)	2
	1	023432	Front Box Kit 3 of 4	55367	Dual Stabilizer Mounting Kit	3
	1	023633	Front Box Kit 4 of 4	55402	Single 5500 Steering Stabilizer (2 req'd)	4
	1	013209	Rear Block Kit	98224828	FOX 2.0 Rear Gas Shock (2 req'd)	7
	2	55828	Rear 5500 Shock			
	1	023630	Box Kit 1 of 4	55312	Single Stabilizer Mounting Kit	1
6" Front / 5.5" Rear IFS w/ Strut Spacer Block & Add-A-Leaf Kit #574H 59FK3412	1	023631	Box Kit 2 of 4	55402	Single 5500 Steering Stabilizer (1 Req'd)	2
	1	023632	Box Kit 3 of 4	55367	Dual Stabilizer Mounting Kit	3
	1	023633	Box Kit 4 of 4	55402	Single 5500 Steering Stabilizer (2 req'd)	6
	1	113219	Add-A-Leaf			7
	1	013507	Rear Block Kit	98224760	FOX 2.0 Rear Gas Shock (2 req'd)	
	2	55760	Rear 5500 Shock	123609	Rear Driveshaft Spacer	
	1	023630	Box Kit 1 of 4			
6" Front / 5.5" Rear IFS w/ Strut Spacer Rear Leaf Springs Kit #575H 65FK2362	1	023631	Box Kit 2 of 4			
	1	023632	Box Kit 3 of 4			
	1	023633	Box Kit 4 of 4			
	2	003509	Rear Leaf Spring			
	1	013508	Rear Box Kit			
	2	55760	Rear 5500 Shock			

Note

1. Supercrew models with 4' bed do not require the add-a-leaf 113219.
2. All wheel drive models will require front driveshaft modification.
3. Stock 17's will not fit back on vehicle. Stock 18's & 20's do fit with stock tires.
4. Rear leaf springs 003509 may be used by removing the factory block.
5. This system also fits 2WD models.
6. Although unusual, a 123609 rear driveshaft spacer may be required.
7. Will not fit HD models (7 lug).
8. Strut compressor required for installation.

2004-2008 FORD F-150 4WD

HIGH CLEARANCE IFS SYSTEM WITH REPLACEMENT STRUTS







#569H - 8" kit

6" & 8" Kit Features

- CNC machined steering knuckles maintain factory steering angles
- One piece front and rear crossmember for increased rigidity
- Front differential skid plate and lateral compression struts included for off-road protection
- Front stainless steel Kevlar lined brake lines included
- No track width change

2004-2008 FORD F-150 4WD WITH REPLACEMENT STRUT

Lift & Method	Qty	Part#	Description	Recommended Accessories	Notes
6" Front / 5.5" Rear IFS System w/strut Block & Add-A-Leaf Kit #570H 78FK4662 	1	023610	Front Box Kit 1 of 4	55338	Single Steering Stabilizer Mount Single 5500 Steering Stabilizer (1 req'd) 55402 55339 Dual Stabilizer Mounting Kit 55402 Dual 5500 Steering Stabilizer (2 req'd) 98224760 FOX 2.0 Rear Gas Shock (2 req'd) 123609 Rear Driveshaft Spacer - 8" kit 
	1	023611	Front Box Kit 2 of 4		
	1	023612	Front Box Kit 3 of 4		
	1	023615	Front Box Kit 4 of 4		
	1	113219	Add-A-Leaf Kit		
	1	013507	Rear Block Kit		
	2	55760	Rear 5500 Shock		
6" Front / 5.5" Rear IFS System w/strut Rear Leaf Springs Kit #571H 84FK3513 	1	023610	Front Box Kit 1 of 4		3 4 5 6 7
	1	023611	Front Box Kit 2 of 4		
	1	023612	Front Box Kit 3 of 4		
	1	023615	Front Box Kit 4 of 4		
	2	003509	Rear Leaf Spring		
	1	013508	Rear Box Kit		
	2	55760	Rear 5500 Shock		
8" Front / 5.5" Rear IFS System w/ Strut Block & Add-a-leaf Kit #568H 81FK6672 	1	023610	Front Box Kit 1 of 4		3 4 5 6 7
	1	023611	Front Box Kit 2 of 4		
	1	023612	Front Box Kit 3 of 4		
	1	023615	Front Box Kit 4 of 4		
	1	113219	Rear Add-a-Leaf		
	1	013507	Rear Block Kit		
	2	55760	Rear 5500 Shock		
8" Front / 5.5" Rear IFS System w/ Strut Leaf Spring Kit #569H 97FK4523 	1	023610	Front Box Kit 1 of 4		3 4 5 6 7
	1	023611	Front Box Kit 2 of 4		
	1	023612	Front Box Kit 3 of 4		
	1	023615	Front Box Kit 4 of 4		
	2	003509	Rear Leaf Spring		
	1	013508	Rear Box Kit		
	2	55760	Rear 5500 Shock		

Notes

1. Supercrew models with 4' bed do not require the add-a-leaf 113219.
2. This system also fits 2WD models.
3. All wheel drive models may require driveshaft modification.
4. Stock 17's will not fit back on vehicle. Stock 18's & 20's do fit with stock tires.
5. Although unusual, a rear driveshaft spacer 123609 may be required.
6. Will not fit HD models (7-lug).
7. Strut compressor required for installation.

CHEVROLET/
GMC

DODGE

FORD

JEEP

SUZUKI

TOYOTA

POSI-LOK

SHOCKS/
STEERING
STABILIZERS

APPAREL/
PROMOTIONAL

PRODUCT
SPECS

VEHICLE
SPECS

Vehicle Specs:
8" Lift Kit
37" D/C FC-II
18" Eagle Alloy 187



Vehicle Specs:
6" Lift Kit
35" BFG A/T
16" Eagle Alloy 186



#514H

6" Kit Features

- Complete bolt on system – no welding required
- No drive shaft replacement required
- CNC machined steering knuckles maintain factory steering geometry
- Torsion bar drop brackets with the BDS logo
- Longer front sway bar links included
- Heavy-duty, one-piece front and rear main crossmembers

1997-2003 FORD F-150 TRUCK 4WD

Lift & Method	Qty	Part#	Description	Recommended Accessories	Notes
6" Front / 5.5" Rear IFS System Rear Blocks & Add-A-Leaf Kit #513H 55FK3802	1	023600	Front Box Kit 1 of 4	55412	1 2
	1	023601	Front Box Kit 2 of 4	PSL750	
	1	023602	Front Box Kit 3 of 4	98224804	
	1	023603	Front Box Kit 4 of 4	98224860	
	1	013559	Rear Box Kit		
	2	55804	Front 5500 Shock		
6" Front / 5.5" Rear IFS System Rear Leaf Springs Kit #514H 28FK5352	2	55860	Rear 5500 Shock		
	1	023600	Front Box Kit 1 of 4		
	1	023601	Front Box Kit 2 of 4		
	1	023602	Front Box Kit 3 of 4		
	1	023603	Front Box Kit 4 of 4		
	2	003559	Rear Leaf Spring		
	1	013509	Rear Box Kit		
	2	55804	Front 5500 Shock		
	2	55860	Rear 5500 Shock		
	2	55860	Rear 5500 Shock		



Note

1. Special tool required to load and unload the torsion bars.
2. Stock 17" wheels can be reinstalled with stock tire.

1980-1996 FORD F-100, F-150 TRUCK

PRO-RIDE SYSTEM

DODGE

FORD

JEEP

SUZUKI

TOYOTA

POSI-LOK

SHOCKS/
STEERING
STABILIZERS

APPAREL/
PROMOTIONAL

PRODUCT
SPECS

VEHICLE
SPECS



6" Standard Kit #509H

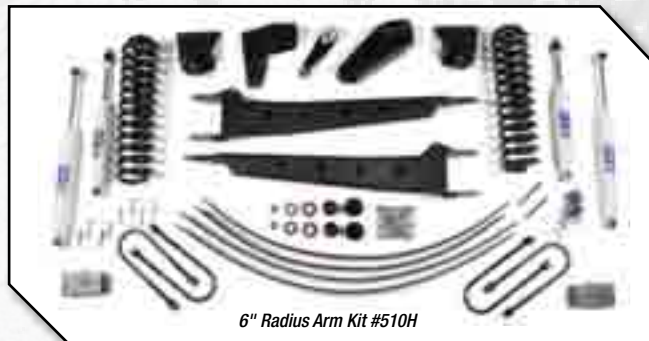

6" Radius Arm Kit #510H

- Pro-Ride coils available in 2", 4", 6" heights over stock for regular and extended cab vehicles
- Extended radius arm kit, includes 36" long extended radius arms to enhance steering angles and insure proper formed tire clearance, plus fully gusseted tubular side plates allow 10" of front wheel travel
- Front box kit used with 4" or 6" coils makes it easy to upgrade from 4" to 6" and includes: pitman arm to correct steering angles, axle pivot brackets that are "dual drilled" for 4" or 6" lifts, and radius arm drop brackets to restore OE caster
- Optional 2", 4" and 6" Glide-Ride rear springs available

1980-1996 FORD F-100, F-150 4WD WITH POWER STEERING

Lift & Method	Qty	Part#	Description	Recommended Accessories	Notes
1-2" Front / 0" Rear Front Coils Kit #359H 12FK824	1	033201	Coil Spring Kit	Page 128	Steering Stabilizers Front 5500 Auxiliary Shock (2 req'd)
	2	129100	Alignment Cam	55800	
	2	55810	Front Standard Shock		
	2	55620	Rear 5500 Shock		
1-2" Front / 2" Rear Front Coils Rear Leaf Springs Kit #383H 97FK639	1	033201	Coil Spring Kit		1 2 4
	2	129100	Alignment Cam		
	2	003208	Rear Leaf Spring		
	4	4051	9/16 x 3-1/4 x 10" Rd U-Bolt		
	2	55810	Front 5500 Shock		
4" Front / 2" Rear Standard Kit Rear Leaf Springs STD Cab Kit #500H EXT Cab Kit #384H 45FK3821	1	033401	Coil Spring Kit (Standard Cab) or	Page 128	1 5 6
	1	033404	Coil Spring Kit (Extended Cab)	55820	
	1	013001	Front Box Kit - Standard	123401	
	2	003208	Rear Leaf Spring	129000	
	4	4051	9/16 x 3-1/4 x 10" Rd U-Bolt	129100	
	2	55800	Front 5500 Shock		
4" Front / 2" Rear Radius Arm Kit Rear Leaf Springs STD Cab Kit #529H EXT Cab Kit #385H 93FK0171	1	033401	Coil Spring Kit (Standard Cab) or		1 5 6
	1	033404	Coil Spring Kit (Extended Cab)		
	1	013003	Front Box Kit - Radius Arm Kit		
	2	003208	Rear Leaf Spring		
	4	4051	9/16 x 3-1/4 x 10" Rd U-Bolt		
	2	55800	Front 5500 Shock		
4" Front / 2" Rear Standard Kit Rear 2" Block Kit STD Cab Kit #501H EXT Cab Kit #386H 75FK348	1	033401	Coil Spring Kit (Standard Cab) or	Page 128	1 5 6
	1	033404	Coil Spring Kit (Extended Cab)	55820	
	1	013001	Front Box Kit - Standard	123401	
	1	063209	Rear 2" Block Kit	063309	
	2	55800	Front 5500 Shock	129000	
	2	55660	Rear 5500 Shock	129100	
4" Front / 2" Rear Radius Arm Kit Rear 2" Block Kit STD Cab Kit #502H EXT Cab Kit #387H 24FK0721	1	033401	Coil Spring Kit (Standard Cab) or		1 5 6
	1	033404	Coil Spring Kit (Extended Cab)		
	1	013003	Front Box Kit - Radius Arm Kit		
	1	063209	Rear 2" Block Kit		
	2	55800	Front 5500 Shock		
	2	55660	Rear 5500 Shock		
4" Front / 2" Rear Standard Kit Rear Add-A-Leafs STD Cab Kit #503H EXT Cab Kit #388H 14FK269	1	033401	Coil Spring Kit (Standard Cab) or	Page 128	1 5 6
	1	033404	Coil Spring Kit (Extended Cab)	55820	
	1	013001	Front Box Kit - Standard	123401	
	1	113209	Dual Add-A-Leafs	129000	
	4	4051	9/16 x 3-1/4 x 10" Rd U-Bolt	129100	
	2	55800	Front 5500 Shock		
4" Front / 2" Rear Radius Arm Kit Rear Add-A-Leafs STD Cab Kit #504H EXT Cab Kit #389H 62FK9831	1	033401	Coil Spring Kit (Standard Cab) or		1 5 6
	1	033404	Coil Spring Kit (Extended Cab)		
	1	013003	Front Box Kit - Radius Arm Kit		
	1	113209	Dual Add-A-Leafs		
	4	4051	9/16 x 3-1/4 x 10" Rd U-Bolt		
	2	55800	Front 5500 Shock		

See Notes ▶

Continued ▶

1980-1996 FORD F-100, F-150 TRUCK

PRO-RIDE SYSTEM



Vehicle Specs:
4" Lift Kit
33" M/T MTZ
15" M/T Classic II

CHEVROLET/
GMC

DODGE

FORD

JEEP

SUZUKI

TOYOTA

POSI-LOK





SHOCKS/
STEERING
STABILIZERS

APPAREL/
PROMOTIONAL

PRODUCT
SPECS

VEHICLE
SPECS

1980-1996 FORD F-100, F-150 4WD STANDARD CAB WITH POWER STEERING (CONTINUED)

Lift & Method	Qty	Part#	Description	Recommended Accessories	Notes
4" Front / 4" Rear Standard Kit Rear Leaf Springs STD Cab Kit #505H EXT Cab Kit #390H 26FK6821	1	033401	Coil Spring Kit (Standard Cab) <i>or</i>	Page 128	Steering Stabilizers 1 4 5
	1	033404	Coil Spring Kit (Extended Cab)	55820	
	1	013001	Front Box Kit - Standard	123401	
	2	003408	Rear Leaf Spring	129000	
	4	4051	9/16 x 3-1/4 x 10" Rd U-Bolt	129100	
	2	55800	Front 5500 Shock		
4" Front / 4" Rear Radius Arm Kit Rear Leaf Springs STD Cab Kit #506H EXT Cab Kit #391H 74FK3171	1	033401	Coil Spring Kit (Standard Cab) <i>or</i>	 <p>#129000 - Bump Stop Extension Kit</p>	
	1	033404	Coil Spring Kit (Extended Cab)		
	1	013003	Front Box Kit - Radius Arm Kit		
	2	003408	Rear Leaf Spring		
	4	4051	9/16 x 3-1/4 x 10" Rd U-Bolt		
	2	55800	Front 5500 Shock		
6" Front / 4" Rear Standard Kit Rear 4" Block Kit STD Cab Kit #507H EXT Cab Kit #392H 11FK368	1	033601	Coil Spring Kit (Standard Cab) <i>or</i>	Page 128	Steering Stabilizers 1 4 5
	1	033604	Coil Spring Kit (Extended Cab)	55819	
	1	013001	Front Box Kit - Standard	123401	
	1	063409	Rear 4" Block Kit	063309	
	2	55820	Front 5500 Shock	129000	
	2	55660	Rear 5500 Shock	129100	
6" Front / 4" Rear Radius Arm Kit Rear 4" Block Kit STD Cab Kit #508H EXT Cab Kit #393H 69FK9821	1	033601	Coil Spring Kit (Standard Cab) <i>or</i>	 <p>#129100 - Alignment Cam</p>	
	1	033604	Coil Spring Kit (Extended Cab)		
	1	013003	Front Box Kit - Radius Arm Kit		
	1	063409	Rear 4" Block Kit		
	2	55820	Front 5500 Shock		
	2	55660	Rear 5500 Shock		
6" Front / 4" Rear Standard Kit Rear 2" Block & Dual Add-A-Leaf Kit STD Cab Kit #509H EXT Cab Kit #394H 62FK399	1	033601	Coil Spring Kit (Standard Cab) <i>or</i>		1 4 5
	1	033604	Coil Spring Kit (Extended Cab)		
	1	013001	Front Box Kit - Standard		
	1	063209	Rear 2" Block Kit		
	1	113209	Dual Add-A-Leaf Kit		
	2	55820	Front 5500 Shock		
6" Front / 4" Rear Radius Arm Kit Rear 2" Block & Dual Add-A-Leaf Kit STD Cab Kit #510H EXT Cab Kit #395H 11FK0241	1	033601	Coil Spring Kit (Standard Cab) <i>or</i>		
	1	033604	Coil Spring Kit (Extended Cab)		
	1	013003	Front Box Kit - Radius Arm Kit		
	1	063209	Rear 2" Block Kit		
	1	113209	Dual Add-A-Leaf Kit		
	2	55820	Front 5500 Shock		
6" Front / 6" Rear Standard Kit Rear Leaf Springs STD Cab Kit #511H EXT Cab Kit #396H 60FK3231	1	033601	Coil Spring Kit (Standard Cab) <i>or</i>		1 4 5
	1	033604	Coil Spring Kit (Extended Cab)		
	1	013001	Front Box Kit - Standard		
	2	003608	Rear Leaf Spring		
	4	4051	9/16 x 3-1/4 x 10" Rd U-Bolt		
	2	55820	Front 5500 Shock		
6" Front / 6" Rear Radius Arm Kit Rear Leaf Springs STD Cab Kit #512H EXT Cab Kit #397H 19FK9471	1	033601	Coil Spring Kit (Standard Cab) <i>or</i>	<p>Extended Radius Arm Upgrade Kit</p> <ul style="list-style-type: none"> Includes extended radius arms and mounting brackets that can be added to existing 4" or 6" BDS Suspension systems <p>#123006.....36FK347</p>	
	1	033604	Coil Spring Kit (Extended Cab)		
	1	013003	Front Box Kit - Radius Arm Kit		
	2	003608	Rear Leaf Spring		
	4	4051	9/16 x 3-1/4 x 10" Rd U-Bolt		
	2	55820	Front 5500 Shock		

Notes

1. Front end alignment required. Alignment cams may be required. See page 118.
2. SuperCab models may not achieve stated lift and may not be alignable.
3. If OE alignment bushing in the upper ball joint are more than 1 degree then 2" coils should not be used.
4. #123401 recommended if equipped with a front anti-sway bar. Ford produced 3 different styles of sway bar systems between 1980 and 1996. In extremely rare cases, modification may be required.
5. Extended lines required for all 4-6" lifts.

1980-1996 FORD F-100, F-150 2WD TRUCK

PRO-RIDE SYSTEM

1980-1996 FORD F-100, F-150 2WD TRUCK WITH POWER STEERING

Lift & Method	Qty	Part#	Description	Recommended Accessories	Notes
1-2" Front / 0" Rear	1	033201	Coil Spring Kit	Page 128 Steering Stabilizers	1 2 4
Front Coils	2	129102	Alignment Cam		
Kit #380H	2	55810	Front 5500 Shock		
99FK624	2	55620	Rear 5500 Shock		
4" Front / 2" Rear	1	033401	Coil Spring Kit (Standard Cab) <i>or</i>	Page 128 Steering Stabilizers	1
Front Coils & Brackets	1	033404	Coil Spring Kit (Extended Cab)		
Rear Add-A-Leafs	1	013001	Front Box Kit	123401 Anti-Sway Bar Drop Kit	3
STD Cab Kit #398H	1	119158	Short Rear Add-A-Leafs	129000 Bump Stop Extension Kit	5
EXT Cab Kit #381H	4	4051	9/16 x 3-1/4 x 10" Rd U-Bolt	Page 133 Alignment Cam (2 req'd)	6
95FK178	2	55800	Front 5500 Shock	119157 Long Rear Add-a-leaf	
	2	55650	Rear 5500 Shock		
6" Front / 4" Rear	1	033601	Coil Spring Kit (Standard Cab) <i>or</i>	Page 128 Steering Stabilizers	1
Front Coils & Brackets	1	033604	Coil Spring Kit (Extended Cab)		
Rear 2" Block Kit and Add-A-Leafs	1	013001	Front Box Kit	123401 Anti-Sway Bar Drop Kit	3
STD Cab Kit #399H	1	119158	Short Rear Add-A-Leafs	129000 Bump Stop Extension Kit	5
EXT Cab Kit #382H	2	55820	Front 5500 Shock	063309 Rear 3" Block Kit	6
44FK209	2	55650	Rear 5500 Shock	Page 133 Alignment Cam (2 req'd)	
				119157 Long Rear Add-a-leaf	

Notes

1. Front end alignment required. Alignment cams may be required. See page 120.
2. SuperCab models may not achieve stated lift and may not be alignable.
3. U-bolts in 2WD rear kits will need to be shortened.
4. If OE alignment bushings in the upper ball joint are more than 1 degree then 2" coils should not be used.
5. #123401 recommended if equipped with a front anti-sway bar. Ford produced 3 different styles of sway bar systems between 1980 and 1996. In extremely rare cases, modification may be required.
6. Extended front brake lines required



#399H - 6" Standard Kit

Radius Arm Upgrade Kit

- Includes extended radius arms and mounting brackets that can be added to existing 4" or 6" BDS Suspension systems

#123006.....36FK347



Vehicle Specs:
2" Lift Kit
33" BFG A/T
15" Centerlines

1973-1979 FORD F-100, F-150 TRUCK

PRO-RIDE SYSTEM

CHEVROLET/
GMC

DODGE

FORD

JEEP

SUZUKI

TOYOTA

POSI-LOK

SHOCKS/
STEERING
STABILIZERS

APPAREL/
PROMOTIONAL

PRODUCT
SPECS

VEHICLE
SPECS



Vehicle Specs:
6" Lift Kit
36" Interco IROKS
15" AR Wheels



6" Pro-Ride Suspension System With Rear Blocks & Add-A-Leafs

4" & 6" Kit Features

- Pro-Ride coils are black powder coated for long life
- Radius arm drop brackets restore OE caster and are gusseted for superior strength
- Front box kit can be used with 4" or 6" system making it easy to upgrade from 4" to 6"
- Track relocation bracket allows full travel and correct axle position
- Optional 4" and 6" Glide-Ride rear springs available

1973-1979 FORD F-100, F-150 4WD

Lift & Method	Qty	Part#	Description	Recommended Accessories	Notes
4" Front / 3" Rear	1	033403	Coil Spring Kit	Page 128 Steering Stabilizers	1
Front Coils & Brackets	1	013002	Radius Arm Drop Kit	55819 Front 5500 Auxiliary Shock (1977-79)	2
Rear 3" Block Kit	1	063309	Rear 3" Block Kit	083402 78-79 Pitman Arm (PS)	3
'73-'76 Kit #370H	1	123001	Track Bar Relocation Kit	129000 Bump Stop Extension Kit	
'77-'79 Kit #371H	2	55820	Front 5500 Shock (77-79) or	063209 Rear 2" Block Kit	
69FK556	2	55875	Front 5500 Shock (1973-76)	063409 Rear 4" Block Kit	
	2	55850	Rear 5500 Shock (1973-79)		
4" Front / 3.5" Rear	1	033403	Coil Spring Kit		
Front Coils & Brackets	1	013002	Radius Arm Drop Kit		
Rear Add-A-Leafs & Rear 2" Block Kit	1	063209	Rear 2" Block Kit		
'77-'79 Kit #372H	1	113208	Add-A-Leaf Kit		
'73-'76 Kit #374H	1	123001	Track Bar Relocation Kit		
'77-'79 Kit #373H	2	55820	Front 5500 Shock (77-79) or		
02FK037	2	55875	Front 5500 Shock (1973-76)		
	2	55850	Rear 5500 Shock (1973-79)		
4" Front / 4" Rear	1	033403	Coil Spring Kit		
Front Coils & Brackets	1	013002	Radius Arm Drop Kit		
Rear Leaf Springs	1	123001	Track Bar Relocation Kit		
'73-'76 Kit #374H	2	003408	Rear Leaf Spring		
'77-'79 Kit #375H	4	4051	9/16 x 3-1/4 x 10" Rd U-Bolts		
04FK6801	2	55820	Front 5500 Shock (77-79) or		
	2	55875	Front 5500 Shock (1973-76)		
	2	55850	Rear 5500 Shock (1973-79)		
6" Front / 5.5" Rear	1	033603	Coil Spring Kit	Page 128 Steering Stabilizers	1
Front Coils & Brackets	1	013002	Radius Arm Drop Kit	55860 Front 5500 Auxiliary Shock (1977-79)	2
Rear 4" Block Kit & Add-A-Leafs	1	063409	Rear 4" Block Kit	083402 78-79 Pitman Arm (PS)	3
'73-'76 Kit #376H	1	113208	Add-A-Leaf Kit		
'77-'79 Kit #377H	1	123001	Track Bar Relocation Kit		
60FK387	2	55850	Front 5500 Shock (77-79) or		
	2	55877	Front 5500 Shock (1973-76)		
	2	55860	Rear 5500 Shock (1973-79)		
6" Front / 5.5" Rear	1	033603	Coil Spring Kit		
Front Coils & Brackets	1	013002	Radius Arm Drop Kit		
Rear Leaf Springs	2	003608	Rear Leaf Spring		
'73-'76 Kit #378H	4	4051	9/16 x 3-1/4 x 10" Rd U-Bolts		
'77-'79 Kit #379H	1	123001	Track Bar Relocation Kit		
61FK6511	2	55850	Front 5500 Shock (77-79) or		
	2	55877	Front 5500 Shock (1973-76)		
	2	55860	Rear 5500 Shock (1973-79)		



#129000 - Bump Stop Extension Kit

Notes

1. Alignment "C" bushings may be required.
2. #003408 and #003608 come with OE style bushings installed.
3. Add two front auxiliary shocks if the vehicle is equipped with factory dual mounts.

1980-1996 FORD BRONCO

PRO-RIDE SYSTEM



**Read more about
Operation Fearless**



#367H - 6" Pro-Ride Radius Arm Suspension System with Dual Add-A-Leafs & Blocks

Pro-Ride coils available in 2", 4", 6" heights over stock
Extended radius arm kit, includes 36" long extended radius arms to enhance steering angles and insure proper formed tire clearance, plus fully gusseted tubular side plates allow 10" of front wheel travel

- Front box kit used with 4" or 6" coils makes it easy to upgrade from 4" to 6" and includes: pitman arm to correct steering angles, axle pivot brackets that are "dual drilled" for 4" or 6" lifts, and radius arm drop brackets to restore OE caster
- Radius arm upgrade kit #123006 includes extended radius arms and mounting brackets that can be added to existing 4" or 6" BDS Suspension Systems (See Page 48)
- Optional 4" and 6" rear Glide-Ride springs available

1980-1996 FORD BRONCO 4WD WITH POWER STEERING

Lift & Method	Qty	Part#	Description	Recommended Accessories	Notes
1"-2" Front / 0" Rear Front Coils Kit #359H 12FK824	1	033201	Coil Spring Kit	Page 128 55800	Steering Stabilizers Front 5500 Auxiliary Shock
	2	129100	Alignment Cam		
	2	55810	Front 5500 Shock		
	2	55620	Rear 5500 Shock		
4" Front / 4" Rear Front Coils & Brackets Rear 4" Block Kit STD Kit #360H STD 30FK368 Radius Arm Kit #361H Radius Arm 88FK9821	1	033401	Coil Spring Kit	Page 128 55820 123401 129000 129100 123411	Steering Stabilizers Front 5500 Auxiliary Shock Anti-Sway Bar Drop Kit Bump Stop Extension Kit Alignment Cam (2 req'd) Rear Sway Bar Drop
	1	013001	Front Box Kit or		
	1	013003	Extended Radius Arm Kit		
	1	063409	Rear 4" Block Kit		
	2	55800	Front 5500 Shock		
	2	55650	Rear 5500 Shock		
4" Front / 4" Rear Front Coils & Brackets Rear Add-A-Leafs Rear 2" Block Kit STD Kit #362H STD 24FK039 Radius Arm Kit #363H Radius Arm 72FK7531	1	033401	Coil Spring Kit	Page 128 55819 123401 129000 129100 123411	Steering Stabilizers Front 5500 Auxiliary Shock Anti-Sway Bar Drop Kit Bump Stop Extension Kit Alignment Cam (2 req'd) Rear Sway Bar Drop
	1	013001	Front Box Kit or		
	1	013003	Extended Radius Arm Kit		
	1	113208	Add-A-Leaf		
	1	063209	Rear 2" Block Kit		
	2	55800	Front 5500 Shock		
4" Front / 4" Rear Front Coils & Brackets Rear Leaf Springs STD Kit #364H STD 45FK3821 Radius Arm Kit #365H Radius Arm 93FK0171	1	033401	Coil Spring Kit	Page 128 55819 123401 129000 129100 123411	Steering Stabilizers Front 5500 Auxiliary Shock Anti-Sway Bar Drop Kit Bump Stop Extension Kit Alignment Cam (2 req'd) Rear Sway Bar Drop
	1	013001	Front Box Kit or		
	1	013003	Extended Radius Arm Kit		
	2	003208	Rear Leaf Spring		
	4	4051	9/16 x 3-1/4 x 10" Rd U-Bolts		
	2	55800	Front 5500 Shock		
6" Front / 6" Rear Front Coils & Brackets Rear 3" Block Kit & Dual Add-A-Leafs STD Kit #366H STD 78FK5001 Radius Arm Kit #367H Radius Arm 27FK2341	1	033601	Coil Spring Kit	Page 128 55819 123401 129000 129100 123411	Steering Stabilizers Front 5500 Auxiliary Shock Anti-Sway Bar Drop Kit Bump Stop Extension Kit Alignment Cam (2 req'd) Rear Sway Bar Drop
	1	013001	Front Box Kit or		
	1	013003	Extended Radius Arm Kit		
	1	063309	Rear 3" Block Kit		
	1	113209	Dual Add-A-Leafs		
	2	55820	Front 5500 Shock		
6" Front / 6" Rear Front Coils & Brackets Rear Leaf Springs STD Kit #368H STD 07FK6821 Radius Arm Kit #369H Radius Arm 55FK3171	1	033601	Coil Spring Kit	Page 128 55819 123401 129000 129100 123411	Steering Stabilizers Front 5500 Auxiliary Shock Anti-Sway Bar Drop Kit Bump Stop Extension Kit Alignment Cam (2 req'd) Rear Sway Bar Drop
	1	013001	Front Box Kit or		
	1	013003	Extended Radius Arm Kit		
	2	003408	Rear Leaf Spring		
	4	4051	9/16 x 3-1/4 x 10" Rd U-Bolts		
	2	55820	Front 5500 Shock		
2	55650	Rear 5500 Shock			

Notes

1. Front end alignment required. Alignment cams may be required. See page 118.
2. If OE alignment bushings in the upper ball joint are more than 1 degree, then 2" coils should not be used.
3. #123401 recommended if equipped with a front anti-sway bar. Ford produced 3 different styles of sway bar systems between 1980 and 1996. In extremely rare cases, modification may be required.
4. #003208, #003408 and #003608 come with OE style bushings installed.
5. Add two front auxiliary shocks if the vehicle is equipped with factory dual mounts.
6. Extended brake lines required.

1978-1979 FORD BRONCO

PRO-RIDE SYSTEM

CHEVROLET/
GMC

DODGE

FORD

JEEP

SUZUKI

TOYOTA

POSI-LOK

SHOCKS/
STEERING
STABILIZERS

APPAREL/
PROMOTIONAL

PRODUCT
SPECS

VEHICLE
SPECS

1978-1979 FORD BRONCO 4WD

Lift & Method	Qty	Part#	Description	Recommended Accessories	Notes	
4" Front / 4" Rear	1	033403	Coil Spring Kit	Page 128	Steering Stabilizers	1
Front Coils & Brackets	1	013002	Radius Arm Drop Kit	55850	Front 5500 Auxiliary Shock (W/ Factory Duals)	
Rear 4" Block Kit	1	063409	Rear 4" Block Kit	083402	78-79 Pitman Arm (PS)	
w/ std shocks Kit #519H	1	123001	Track Bar Relocation Kit	129000	Bump Stop Extension Kit	
w/ stag shocks Kit #520H	2	55820	Front 5500 Shock or	063309	Rear 3" Block Kit	
18FK266	1	55850	Front Driver Side w/ Staggered Mounts			
	1	55820	Front Passenger Side w/ Staggered Mounts			
	2	55650	Rear 5500 Shock			
4" Front / 3.5" Rear	1	033403	Coil Spring Kit			1
Front Coils & Brackets	1	013002	Radius Arm Drop Kit			
Rear Add-A-Leafs &	1	063209	Rear 2" Block Kit			
Rear 2" Block Kit	1	113208	Add-A-Leaf Kit			
w/ std shocks Kit #521H	1	123001	Track Bar Relocation Kit			
w/ stag shocks Kit #522H	2	55820	Front 5500 Shock or			
02FK037	1	55850	Front Driver Side w/ Staggered Mounts			
	1	55820	Front Passenger Side w/ Staggered Mounts			
	2	55650	Rear 5500 Shock			
4" Front / 4" Rear	1	033403	Coil Spring Kit			1
Front Coils & Brackets	1	013002	Radius Arm Drop Kit			2
Rear Leaf Springs	1	123001	Track Bar Relocation Kit			
w/ std shocks Kit #523H	2	003208	Rear Leaf Spring			
w/ stag shocks Kit #524H	4	4051	9/16 x 3-1/4 x 10" Rear U-Bolts			
23FK3801	2	55820	Front 5500 Shock or			
	1	55850	Front Driver Side w/ Staggered Mounts			
	1	55820	Front Passenger Side w/ Staggered Mounts			
	2	55650	Rear 5500 Shock			
6" Front / 5.5" Rear	1	033603	Coil Spring Kit	Page 128	Steering Stabilizers	1
Front Coils & Brackets	1	013002	Radius Arm Drop Kit	55860	Front 5500 Auxiliary Shock (W/ Factory Duals)	
Rear 4" Block Kit &	1	063409	Rear 4" Block Kit	083402	78-79 Pitman Arm (PS)	
Rear Add-A-Leafs	1	113208	Add-A-Leaf Kit	129000	Bump Stop Extension Kit	
w/ std shocks Kit #525H	1	123001	Track Bar Relocation Kit			
w/ stag shocks Kit #526H	2	55850	Front 5500 Shock or			
60FK387	1	55860	Front Driver Side w/ Staggered Mounts			
	1	55850	Front Passenger Side w/ Staggered Mounts			
	2	55650	Rear 5500 Shock			
6" Front / 6" Rear	1	033603	Coil Spring Kit			1
Front Coils & Brackets	1	013002	Radius Arm Drop Kit			2
Rear Leaf Springs	1	123001	Track Bar Relocation Kit			
w/ std shocks Kit #527H	2	003408	Rear Leaf Spring			
w/ stag shocks Kit #528H	4	4051	9/16 x 3-1/4 x 10" Rd U-Bolts			
08FK9111	2	55850	Front 5500 Shock or			
	1	55860	Front Driver Side w/ Staggered Mounts			
	1	55850	Front Passenger Side w/ Staggered Mounts			
	2	55650	Rear 5500 Shock			

Notes

- Alignment "C" bushings may be required.
- #003208, #003408 and #003608 are 3" wide and come with OE style bushings installed.



6" Pro-Ride Suspension System With Rear Blocks & Add-A-Leafs

4" & 6" Kit Features

- Pro-Ride coils are black powder coated for long life
- Radius arm drop brackets restore OE caster and are gusseted for superior strength
- Front box kit can be used with 4" or 6" system making it easy to upgrade from 4" to 6"
- Track bar relocation bracket allows full travel and correct axle position
- Optional 4" and 6" Glide-Ride rear springs available

2005-2014 FORD F-250, F-350 SUPER DUTY 4WD

PRO-RIDE SYSTEM

CHEVROLET/
GMC

DODGE

FORD

JEEP

SUZUKI

TOYOTA

POSI-LOK

SHOCKS/
STEERING
STABILIZERS

APPAREL/
PROMOTIONAL

PRODUCT
SPECS

VEHICLE
SPECS



Kit#326H

2" Kit Features

- 6061 aluminum one piece lower coil mounts
- Lower mounts are bolted solid so there are no loose parts
- Box kit includes ball joint alignment cams to properly align the vehicle
- Includes front and rear BDS5500 shocks



4", 6", 8" 4- Link System Features

- Pro-Ride coil springs are supplied that are capable of full coil bind as well as specifically designed springs for gas vs. diesel motors
- Frame mounting bracket replaces OE radius arm bracket to increase ground clearance vs. a standard drop kit
- Less than 1 degree of caster change through wheel travel giving you better on and offroad control
- Massive 2.5" O.D., greaseable, urethane control arm bushings
- 2" O.D. x 0.250" wall DOM tubing is used to make these extremely rugged control arms
- The heavy duty track bar relocation bracket is designed to match the steering angles of the supplied dropped pitman arm to maintain the factory steering geometry
- This system also includes bump stop extensions, brake line extensions, sway bar drops and a new steering stabilizer
- These systems are available with either rear block kits or new Glide-Ride rear leaf springs

4" & 6" Standard Kit Features

- Pro-Ride coil springs are supplied that are capable of full coil bind as well as specifically designed springs for gas vs. diesel motors
- Heavy duty track bar relocation bracket is included to properly center the axle as well as match the steering angles created by the supplied drop pitman arm
- Radius arm drop brackets are included to restore the O.E. caster angles
- A hard line extension is supplied to properly lengthen the O.E. brake lines
- These systems are available with either rear block kits or new Glide-Ride rear leaf springs

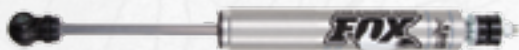

**2.0 PERFORMANCE
SERIES SHOCKS**



Vehicle Specs:
8" 4-Link Lift Kit
40" Interco M-16
22" BMF Wheel

2011-2014 FORD F-250, F-350 SUPER DUTY 4WD - DIESEL

PRO-RIDE SYSTEM

CHEVROLET/
GMC

DODGE

FORD

JEEP

SUZUKI

TOYOTA

POSI-LOK

SHOCKS/
STEERING
STABILIZERS

APPAREL/
PROMOTIONAL

PRODUCT
SPECS

VEHICLE
SPECS



#588H - 4" Standard Kit



4-link kit installed - Shown in gray, available in black only.



Vehicle Specs:
8" Lift Kit
37" Toyo M/T
22x12 American Force

2011-2014 FORD F-250, F-350 SUPER DUTY 4WD - DIESEL

Lift & Method	Qty	Part#	Description	Recommended Accessories	Notes
1" Front/0" Rear Front Coil Mount Kit # 325H 29FK152	1	013101	Front Coil Mounts	98224710	FOX 2.0 Front Gas Shock (2 req'd) FOX 2.0 Rear Gas Shock (2 req'd) 55309 Single Stabilizer Mounting Kit 55415 Single 5500 Steering Stabilizer or 95415 Single 9500 Steering Stabilizer 123202 Adjustable Track Bar
	2	55710	Front 5500 Shock	98224660	
	2	55660	Rear 5500 Shock		
2" Front/0" Rear Front Coil Mount Kit # 326H 41FK903	1	013201	Front Coil Mounts		
	2	55710	Front 5500 Shock		
	2	55660	Rear 5500 Shock		
4" Front /3" Rear Standard Kit Front Coil & Bracket Kit Rear Block Kit #588H 35FK5611	1	033411	Front Coil Springs	123402	Carrier Bearing Drop Kit FOX 2.0 Front Gas Shock (2 req'd) FOX 2.0 Rear Gas Shock (2 req'd) 55368 Single Stabilizer Mounting Kit 55415 Single 5500 Steering Stabilizer or 95415 Single 9500 Steering Stabilizer 55358 Dual Stabilizer Mounting Kit 55405 Dual 5500 Steering Stabilizer or 95405 Dual 9500 Steering Stabilizer 123023 Front Dual Shock Hoop Kit 55759 Dual 5500 Front Shocks (4 req'd) or 98224759 FOX 2.0 Dual Gas Shock (4 req'd) 123009 Rear Sway Bar Links 123020 Bumper Spacer Kit 113209 Single Add-A-Leaf 113208 Dual Add-A-Leaf 123202 Adjustable Track Bar
	1	013413	Front Box Kit	98224700	
	1	013519	Rear Block Kit	98224760	
	2	55700	Front 5500 Shock		
	2	55760	Rear 5500 Shock		
	2	55760	Rear 5500 Shock		
4" Front / 3" Rear 4-Link System Front Coil & Bracket Kit Rear Block Kit #590H 33FK6102	1	033411	Front Coils Springs		1 2 3 4 5
	1	013010	4-Link Box 1 of 2		
	1	013013	4-Link Box 2 of 2		
	1	013519	Rear Block Kit		
	2	55700	Front 5500 Shock		
	2	55760	Rear 5500 Shock		
4" Front /3" Rear Standard Kit Front Coil & Bracket Kit Rear Leaf Spring Kit #592H 26FK2791	1	033411	Front Coil Springs	123009	
	1	013413	Front Box Kit	123020	
	2	003619	Rear Leaf Spring		
	1	013409	Rear Box Kit		
	2	55700	Front 5500 Shock		
	2	55760	Rear 5500 Shock		
4" Front / 3" Rear 4-Link System Front Coil & Bracket Kit Rear Leaf Spring Kit #593H 24FK3282	1	033411	Front Coils Springs		
	1	013010	4-Link Box 1 of 2		
	1	013013	4-Link Box 2 of 2		
	2	003619	Rear Leaf Springs		
	1	013409	Rear Box Kit		
	2	55700	Front 5500 Shock		
	2	55760	Rear 5500 Shock		



#123202 - Adjustable Track Bar

See Notes ▶

Continued ▶

2011-2014 FORD F-250, F-350 SUPER DUTY 4WD - DIESEL					
Lift & Method	Qty	Part#	Description	Recommended Accessories	Notes
6" Front / 5" Rear Standard Kit Front Coil & Bracket Kit Rear Leaf Spring w/ 2" OE Block Kit #594H w/ 3-1/2" OE Block #595H 41FK8612	1	033611	Front Coil Springs	SHOCKS 98224750 FOX 2.0 Front Gas Shock - 6" kit (2 req'd) 98224751 FOX 2.0 Front Gas Shock - 8" kit (2 req'd) 98224760 FOX 2.0 Rear Gas Shock - 6" kit (2 req'd) 98224765 FOX 2.0 Rear Gas Shock - 8" kit (2 req'd) 123023 Front Dual Shock Hoop Kit 55769 Dual 5500 Front Shocks - 6" kit (4 req'd) or 98224769 FOX 2.0 Dual Gas Shock - 6" kit (4 req'd) 55761 Dual 5500 Front Shocks - 8" kit (4 req'd) or 98224761 FOX 2.0 Dual Gas Shock - 8" kit (4 req'd)	2
	1	013610	Front Box Kit		2
	2	003619	Rear Leaf Spring		4
	1	013608	Rear Box Kit - 2" Factory Block or		5
	1	013609	Rear Box Kit - 3-1/2" Factory Block		
6" Front / 5" Rear 4-Link System Front Coil & Bracket Kit Rear Leaf Spring w/ 2" OE Block Kit # 596H w/ 3-1/2" OE Block # 597H 53FK1592	1	033611	Front Coils Springs	STABILIZERS 55368 Single Steering Stabilizer Mounting Kit 55415 Single 5500 Steering Stabilizer or 95415 Single 9500 Steering Stabilizer 55358 Dual Steering Stabilizer Mounting Kit 55405 Dual 5500 Steering Stabilizer or 95405 Dual 9500 Steering Stabilizer	2
	1	013010	4-Link Box 1 of 2		3
	1	013014	4-Link Box 2 of 2		4
	2	003619	Rear Leaf Springs		5
	2	013608	Rear Box Kit - 2" Factory Block or		6
8" Front / 8" Rear 4-Link System Front Coil & 4-Link Rear Leaf Spring Kit #1500H 93FK7703	1	013609	Rear Box Kit - 3-1/2" Factory Block	T-CASE/DRIVELINE MODIFICATION 123402 Carrier Bearing Drop Kit - 6" kit 123406 Carrier Bearing Drop Kit - 8" kit	2
	2	55750	Front 5500 Shock		3
	2	55760	Rear 5500 Shock		4
	1	033811	Front Coil Springs (Diesel)		5
	1	013810	4-Link Kit Box 1 of 2		6
8" Front / 8" Rear 4-Link System Front Coil & 4-Link Rear Leaf Spring Kit #1500H 93FK7703	1	013813	4-Link Kit Box 2 of 2	ACCESSORIES 123009 Rear Sway Bar Links 123020 Front Bumper Spacer Kit 123202 Adjustable Track Bar	2
	1	003829	Rear Leaf Spring		3
	2	55751	Front 5500 Shock		4
	2	55765	Rear 5500 Shock		5
	2	55765	Rear 5500 Shock		6

Notes:

◀ **Continued**

1. Removal of factory block required. Net rear lift height will vary depending on height of factory block, but will result in a level stance.
2. Front exhaust modification may be required to clear front drive shaft (gas only).
3. If equipped with 2-piece driveshaft, a Carrier Bearing Drop Kit may be required.
4. Although extremely rare, front driveline vibration may occur.
5. If equipped with rear sway bar, #123009 required.
6. Front bumper spacer kit #123020 may be required to run 38"x15.50" tires.

2011-2014 FORD F-250, F-350 SUPER DUTY 4WD - GAS



Vehicle Specs:
8" Lift Kit w/ Dual FOX Shocks
38" Nitto M/T
24" American Force

2011-2014 FORD F-250, F-350 SUPER DUTY 4WD - GAS

Lift & Method	Qty	Part#	Description	Recommended Accessories	Notes
1" Front/0" Rear Front Coil Mount Kit # 325H 29FK152	1	013101	Front Coil Mounts	98224710 FOX 2.0 Front Gas Shock (2 req'd) 98224660 FOX 2.0 Rear Gas Shock (2 req'd) 55309 Single Stabilizer Mounting Kit 55415 Single 5500 Steering Stabilizer or 95415 Single 9500 Steering Stabilizer 123202 Adjustable Track Bar	
	2	55710	Front 5500 Shock		
	2	55660	Rear 5500 Shock		
2" Front/0" Rear Front Coil Mount Kit # 326H 41FK903	1	013201	Front Coil Mounts		
	2	55710	Front 5500 Shock		
	2	55660	Rear 5500 Shock		

See Notes ▶

Continued ▶



9500 Series Steering Stabilizer Mounting Systems

Features Include:

- Hydraulic stabilizer cylinders with a brushed stainless appearance and a top clear coat
- Heavy-duty gusseted mounting brackets
- All hardware and instructions included

Installation of Complete System Will...

- Enhance vehicle control with reduced steering shimmy and bump steer
- Improve tire wear and front-end component life
- Lessen side-to-side motion caused by wide tires and road conditions



2011-2014 FORD F-250, F-350 SUPER DUTY 4WD - GAS

Lift & Method	Qty	Part#	Description	Recommended Accessories	Notes
4" Front / 3" Rear Standard Kit Front Coil & Bracket Kit Rear Block Kit Kit #578H 56FK8611	1	033412	Front Coil Springs	123402 Carrier Bearing Drop Kit	1 2 3 4 5
	1	013413	Front Box Kit	113209 Single Add-A-Leaf	
	1	013519	Rear Block Kit	113208 Dual Add-A-Leaf	
	2	55700	Front 5500 Shock	98224700 FOX 2.0 Front Gas Shock (2 req'd)	
	2	55760	Rear 5500 Shock	98224760 FOX 2.0 Rear Gas Shock (2 req'd)	
4" Front / 3" Rear 4-Link System Front Coil & Bracket Kit Rear Block Kit Kit # 580H 54FK9102	1	033412	Front Coils Springs	55368 Single Stabilizer Mounting Kit	
	1	013010	4-Link Box 1 of 2	55415 Single 5500 Steering Stabilizer or 95415 Single 9500 Steering Stabilizer	
	1	013013	4-Link Box 2 of 2	55358 Dual Stabilizer Mounting Kit	
	1	013519	Rear Block Kit	55405 Dual 5500 Steering Stabilizer (2 req'd) or 95405 Dual 9500 Steering Stabilizer (2 req'd)	
	2	55700	Front 5500 Shock	123023 Front Dual Shock Hoop Kit	
4" Front / 3" Rear Standard Kit Front Coil & Bracket Kit Rear Leaf Spring Rear Leaf Spring Kit #582H 47FK5791	1	033412	Front Coil Springs	55759 Dual 5500 Front Shocks (4 req'd)	
	1	013413	Front Box Kit	98224759 FOX 2.0 Dual Gas Shock (4 req'd)	
	2	003619	Rear Leaf Spring	123020 Bumper Spacer Kit	
	1	013409	Rear Box Kit	123202 Adjustable Track Bar	
	2	55700	Front 5500 Shock		
4" Front / 3" Rear 4-Link System Front Coil & Bracket Kit Rear Leaf Spring Kit #583H 45FK6282	1	033412	Front Coils Springs		
	1	013010	4-Link Box 1 of 2		
	1	013013	4-Link Box 2 of 2		
	2	003619	Rear Leaf Springs		
	2	55700	Front 5500 Shock		
6" Front / 5" Rear Standard Kit Front Coil & Bracket Kit Rear Leaf Spring w/ 2" OE Block Kit #584H w/ 3-1/2" OE Block #585H 62FK1712	1	033612	Front Coil Springs		2 3 4 5
	1	013610	Front Box Kit	SHOCKS	
	2	003619	Rear Leaf Spring	98224750 FOX 2.0 Front Gas Shock - 6" kit (2 req'd)	
	1	013608	Rear Box Kit - 2" Factory Block or 013609 Rear Box Kit - 3-1/2" Factory Block	98224751 FOX 2.0 Front Gas Shock - 8" kit (2 req'd)	
	2	55750	Front 5500 Shock	98224760 FOX 2.0 Rear Gas Shock - 6" kit (2 req'd)	
6" Front / 5" Rear 4-Link System Front Coil & Bracket Kit Rear Leaf Spring w/ 2" OE Block Kit #586H w/ 3-1/2" OE Block #587H 74FK4592	1	033612	Front Coils Springs	98224765 FOX 2.0 Rear Gas Shock - 8" kit (2 req'd)	
	1	013010	4-Link Box 1 of 2	123023 Front Dual Shock Hoop Kit	
	1	013014	4-Link Box 2 of 2	55769 Dual 5500 Front Shocks - 6" kit (4 req'd) or 98224769 FOX 2.0 Dual Gas Shock - 6" kit (4 req'd)	
	2	003619	Rear Leaf Springs	55761 Dual 5500 Front Shocks - 8" kit (4 req'd) or 98224761 FOX 2.0 Dual Gas Shock - 8" kit (4 req'd)	
	1	013608	Rear Box Kit - 2" Factory Block or 013609 Rear Box Kit - 3-1/2" Factory Block	STABILIZERS	
8" Front / 8" Rear 4-Link System Front Coil & 4-Link Rear Leaf Spring Kit #1501H 93FK7703	1	033812	Front Coil Springs (Gas)	55368 Single Steering Stabilizer Mounting Kit	1 2 3 4 5 6
	1	013810	4-Link Kit Box 1 of 2	55415 Single 5500 Steering Stabilizer or 95415 Single 9500 Steering Stabilizer	
	1	013813	4-Link Kit Box 2 of 2	55358 Dual Steering Stabilizer Mounting Kit	
	1	003829	Rear Leaf Spring	55405 Dual 5500 Steering Stabilizer or 95405 Dual 9500 Steering Stabilizer	
	2	55751	Front 5500 Shock	T-CASE/DRIVELINE MODIFICATION	
ACCESSORIES	2	55765	Rear 5500 Shock	123402 Carrier Bearing Drop Kit - 6" kit	
	2	55765	Rear 5500 Shock	123406 Carrier Bearing Drop Kit - 8" kit	
	2	55765	Rear 5500 Shock	ACCESSORIES	
				123009 Rear Sway Bar Links - 8" kit	
				123020 Front Bumper Spacer Kit	
				123202 Adjustable Track Bar	



Notes:

1. Removal of factory block required. Net rear lift height will vary depending on height of factory block, but will result in a level stance.
2. Front exhaust modification may be required to clear front drive shaft.
3. If equipped with 2-piece driveshaft, a Carrier Bearing Drop Kit is required.
4. Although extremely rare, front driveline vibration may occur.
5. If equipped with rear sway bar use 123009.
6. Front bumper spacer kit #123020 may be required to run 38"x15.50" tires.

◀ Continued

2008-2010 FORD F-250, F-350 SUPER DUTY 4WD - DIESEL

2008-2010 FORD F-250, F-350 SUPER DUTY DIESEL ONLY 4WD

Lift & Method	Qty	Part#	Description	Recommended Accessories	Notes
1" Front / 0" Rear	1	013101	Front Coil Mounts	98224710	
Front Coil Mount	2	55710	Front 5500 Shock	98224660	
Kit #325H	2	55660	Rear 5500 Shock	55309	
29FK152				55415	
2" Front / 0" Rear	1	013201	Front Coil Mounts	95415	
Front Coil Mount	2	55710	Front 5500 Shock	123202	
Kit #326H	2	55660	Rear 5500 Shock		
41FK903					
4" Front / 3" Rear	1	033411	Front Coil Springs (Diesel)	123402	1
Standard Kit	1	013412	Front Box Kit	98224700	
Front Coil & Bracket Kit	1	013519	Rear Block Kit w/o top overload or	98224760	
Rear Block Kit	1	013518	Rear Block Kit w/ top overload	55358	
w/o top ovid Kit #546H	1	55415	Single 5500 Steering Stabilizer	55405	
w/ top ovid Kit #547H	2	55700	Front 5500 Shock	95405	
44FK3321	2	55760	Rear 5500 Shock	123023	
4" Front / 3" Rear	1	033411	Front Coil Springs (Diesel)	55759	
4-Link System	1	013010	4-Link Kit Box 1 of 2	98224759	
Front Coil & Bracket Kit	1	013012	4-Link Kit Box 2 of 2		
Rear Block Kit	1	013519	Rear Block Kit w/o top overload or	123009	
w/o top ovid Kit #548H	1	013518	Rear Block Kit w/ top overload	123020	
w/ top ovid Kit #549H	1	55415	Single 5500 Steering Stabilizer	123202	
42FK4802	2	55700	Front 5500 Shock		
	2	55760	Rear 5500 Shock		
4" Front / 4" Rear	1	033411	Front Coil Springs (Diesel)		
Standard Kit	1	013412	Front Box Kit		
Front Coil & Bracket Kit	2	003619	Rear Leaf Spring		
Rear Leaf Spring	4	4032	5/8 x 3-5/8 x 10" Round U-bolt		
Kit #554H	1	55415	Single 5500 Steering Stabilizer		
28FK5102	2	55700	Front 5500 Shock		
	2	55760	Rear 5500 Shock		
4" Front / 4" Rear	1	033411	Front Coil Springs (Diesel)		
4-Link System	1	013010	4-Link Kit Box 1 of 2		
Front Coil & 4-Link	1	013012	4-Link Kit Box 2 of 3		
Rear Leaf Springs	2	003619	Rear Leaf Spring		
Kit #555H	4	4032	5/8 x 3-5/8 x 10" Round U-bolt		
26FK6682	1	55415	Single 5500 Steering Stabilizer		
	2	55700	Front 5500 Shock		
	2	55760	Rear 5500 Shock		



4-Link Upgrade Kit

- Upgrade your standard kit to a 4-link system for superior handling and on/off road performance
- Works on 2-6" lift kits

#123011/123012.....89FK4301



FOX 2.0 PERFORMANCE SERIES SHOCKS



2008-2010 FORD F-250, F-350 SUPER DUTY 4WD - DIESEL

CHEVROLET/
GMC

DODGE

FORD

JEEP

SUZUKI

TOYOTA



4-Link Upgrade Kit

- Upgrade your standard kit to a 4-link system for superior handling and on/off road performance
- Works on 2-6" lift kits

#123011/123012.....89FK4301

2008-2010 FORD F-250, F-350 SUPER DUTY DIESEL ONLY 4WD

Lift & Method	Qty	Part#	Description	Recommended Accessories	Notes			
6" Front / 3" Rear Standard Kit Rear Block Kit w/o top ovlid Kit #558H w/ top ovlid Kit #559H 69FK8241	1	033611	Front Coil Springs (Diesel)	SHOCKS 98224750 FOX 2.0 Front Gas Shock - 6" kit (2 req'd) 98224751 FOX 2.0 Front Gas Shock - 8" kit (2 req'd) 98224760 FOX 2.0 Rear Gas Shock - 6" kit (2 req'd) 98224765 FOX 2.0 Rear Gas Shock - 8" kit (2 req'd) 123023 Front Dual Shock Hoop Kit 55769 Dual 5500 Front Shocks - 6" kit (4 req'd) or 98224769 FOX 2.0 Dual Gas Shock - 6" kit (4 req'd) 55761 Dual 5500 Front Shocks - 8" kit (4 req'd) or 98224761 FOX 2.0 Dual Gas Shock - 8" kit (4 req'd) STABILIZERS 55358 Dual Steering Stabilizer Mounting Kit 55405 Dual 5500 Steering Stabilizer or 95405 Dual 9500 Steering Stabilizer T-CASE/DRIVELINE MODIFICATION 123402 Carrier Bearing Drop Kit - 6" kit 123406 Carrier Bearing Drop Kit - 8" kit ACCESSORIES 123009 Rear Sway Bar Links 123020 Front Bumper Spacer Kit 123202 Adjustable Track Bar	1	013612	Front Box Kit	1
	1	013519	Rear Block Kit w/o top overload or		2			
	1	013518	Rear Block Kit w/ top overload		4			
	1	55415	Single 5500 Steering Stabilizer		5			
	2	55750	Front 5500 Shock					
	2	55760	Rear 5500 Shock					
6" Front / 3" Rear 4-Link System Front Coil & 4-Link Rear Block Kit w/o top ovlid Kit #560H w/ top ovlid Kit #561H 71FK2122	1	033611	Front Coil Springs (Diesel)					
	1	013010	4-Link Kit Box 1 of 2					
	1	013613	4-Link Kit Box 2 of 2					
	1	013519	Rear Block Kit w/o top overload or					
	1	013518	Rear Block Kit w/ top overload					
	1	55415	Single 5500 Steering Stabilizer					
6" Front / 6" Rear Standard Kit Front Coil & Bracket Kit Rear Leaf Spring Kit #552H 43FK1122	1	033611	Front Coil Springs (Diesel)					
	1	013612	Front Box Kit		4			
	2	003619	Rear Leaf Spring		5			
	4	4033	5/8 x 3-5/8 x 12" Round U-bolt					
	1	55415	Single 5500 Steering Stabilizer					
	2	55750	Front 5500 Shock					
6" Front / 6" Rear 4-Link System Front Coil & 4-Link Rear Leaf Spring Kit #553H 55FK4992	2	55760	Rear 5500 Shock					
	1	033611	Front Coil Springs (Diesel)					
	1	013010	4-Link Kit Box 1 of 2					
	1	013613	4-Link Kit Box 2 of 2					
	2	003619	Rear Leaf Spring					
	4	4033	5/8 x 3-5/8 x 12" Round U-bolt					
8" Front / 8" Rear 4-Link System Front Coil & 4-Link Rear Leaf Spring Kit #567H 86FK6403	1	55415	Single 5500 Steering Stabilizer					
	2	55750	Front 5500 Shock					
	2	55760	Rear 5500 Shock					
	1	033811	Front Coil Springs (Diesel)					
	1	013810	4-Link Kit Box 1 of 2		3			
	1	013812	4-Link Kit Box 2 of 2		4			



#123023 - Front Dual Shock Hoop

Notes

1. Removal of factory block required.
2. This listing will give a tail low stance of approximately 3".
3. Bumper spacer kit #123020 required to run 38" tires.
4. Although extremely rare, front driveline vibration may occur.
5. If equipped with 2-piece driveshaft, a Carrier Bearing Drop Kit is required.

2008-2010 FORD F-250, F-350 SUPER DUTY 4WD - GAS



Vehicle Specs:
4" Lift Kit
35" Kumho A/T
20" Eagle Alloy 064

2008-2010 FORD F-250, F-350 SUPER DUTY GAS ONLY 4WD

Lift & Method	Qty	Part#	Description	Recommended Accessories	Notes
1" Front / 0" Rear	1	013101	Front Coil Mounts	98224710	
Front Coil Mount	2	55710	Front 5500 Shock	98224660	
Kit #325H 29FK152	2	55660	Rear 5500 Shock	55309 55415 95415	
2" Front / 0" Rear	1	013201	Front Coil Mounts	123202	
Front Coil Mount	2	55710	Front 5500 Shock		
Kit #326H 41FK903	2	55660	Rear 5500 Shock		
4" Front / 3" Rear	1	033412	Front Coil Springs (Gas)	123402	1 3
Standard Kit	1	013412	Front Box Kit	98224700	
Front Coil & Bracket Kit	1	013519	Rear Block Kit w/o top overload or	98224760	
Rear Block Kit	1	013518	Rear Block Kit w/ top overload	55358	
w/o top ovlid Kit #542H	1	55415	Single 5500 Steering Stabilizer	55405	
w/ top ovlid Kit #543H	2	55700	Front 5500 Shock	95405	
65FK6321	2	55760	Rear 5500 Shock	123023	
4" Front / 3" Rear	1	033412	Front Coil Springs (Gas)	55759	
4-Link System	1	013010	4-Link Kit Box 1 of 2	98224759	
Front Coil & Bracket Kit	1	013012	4-Link Kit Box 2 of 2	123009	
Rear Block Kit	1	013519	Rear Block Kit w/o top overload or	123020	
w/o top ovlid Kit #544H	1	013518	Rear Block Kit w/ top overload	123202	
w/ top ovlid Kit #545H	1	55415	Single 5500 Steering Stabilizer		
63FK7802	2	55700	Front 5500 Shock		
	2	55760	Rear 5500 Shock		
4" Front / 4" Rear	1	033412	Front Coil Springs (Gas)		
Standard Kit	1	013412	Front Box Kit		
Front Coil & Bracket Kit	2	003619	Rear Leaf Spring		
Rear Leaf Spring	4	4032	5/8 x 3-5/8 x 10" Round U-bolt		
Kit #556H	1	55415	Single 5500 Steering Stabilizer		
49FK8102	2	55700	Front 5500 Shock		
	2	55760	Rear 5500 Shock		
4" Front / 4" Rear	1	033412	Front Coil Springs (Gas)		
4-Link System	1	013010	4-Link Kit Box 1 of 2		
Front Coil & 4-Link	1	013012	4-Link Kit Box 2 of 3		
Rear Leaf Springs	2	003619	Rear Leaf Spring		
Kit #557H	4	4032	5/8 x 3-5/8 x 10" Round U-bolt		
47FK6982	1	55415	Single 5500 Steering Stabilizer		
	2	55700	Front 5500 Shock		
	2	55760	Rear 5500 Shock		

4-Link Upgrade Kit

- Upgrade your standard kit to a 4-link system for superior handling and on/off road performance
- Works on 2-6" lift kits

#123011/123012 89FK4301

See Notes ►

Continued ►



2.0 PERFORMANCE SERIES SHOCKS

2008-2010 FORD F-250, F-350 SUPER DUTY 4WD - GAS

CHEVROLET/
GMC

DODGE

FORD

JEEP

SUZUKI

TOYOTA

POSI-LOK



SHOCKS/
STEERING
STABILIZERS

APPAREL/
PROMOTIONAL

PRODUCT
SPECS

VEHICLE
SPECS

2008-2010 FORD F-250, F-350 SUPER DUTY 4WD - GAS

Lift & Method	Qty	Part#	Description	Recommended Accessories	Notes
6" Front / 3" Rear Standard Kit Rear Block Kit w/o top ovid Kit #562H w/ top ovid Kit #563H 80FK2341	1	033612	Front Coil Springs (Gas)	SHOCKS 98224750 FOX 2.0 Front Gas Shock - 6" kit (2 req'd) 98224751 FOX 2.0 Front Gas Shock - 8" kit (2 req'd) 98224760 FOX 2.0 Rear Gas Shock - 6" kit (2 req'd) 98224765 FOX 2.0 Rear Gas Shock - 8" kit (2 req'd) 123023 Front Dual Shock Hoop Kit 55769 Dual 5500 Front Shocks - 6" kit (4 req'd) or 98224769 FOX 2.0 Dual Gas Shock - 6" kit (4 req'd) 55761 Dual 5500 Front Shocks - 8" kit (4 req'd) or 98224761 FOX 2.0 Dual Gas Shock - 8" kit (4 req'd)	1
	1	013612	Front Box Kit		2
	1	013519	Rear Block Kit w/o top overload or		3
	1	013518	Rear Block Kit w/ top overload		5
	1	55415	Single 5500 Steering Stabilizer		6
	2	55750	Front 5500 Shock		
6" Front / 3" Rear 4-Link System Front Coil & 4-Link Rear Block Kit w/o top ovid Kit #564H w/ top ovid Kit #565H 92FK5122	1	033612	Front Coil Springs (Gas)	STABILIZERS 55358 Dual Steering Stabilizer Mounting Kit 55405 Dual 5500 Steering Stabilizer or 95405 Dual 9500 Steering Stabilizer T-CASE/DRIVELINE MODIFICATION 123402 Carrier Bearing Drop Kit - 6" kit 123406 Carrier Bearing Drop Kit - 8" kit ACCESSORIES 123009 Rear Sway Bar Links 123020 Bumper Spacer Kit 123202 Adjustable Track Bar	3
	1	013010	4-Link Kit Box 1 of 2		5
	1	013613	4-Link Kit Box 2 of 2		6
	1	013519	Rear Block Kit w/o top overload or		
	1	013518	Rear Block Kit w/ top overload		
	1	55415	Single 5500 Steering Stabilizer		
6" Front / 6" Rear Standard Kit Front Coil & Bracket Kit Rear Leaf Spring Kit #550H 64FK4122	1	033612	Front Coil Springs (Gas)	 #113209 Dual Add-A-Leaf	3
	1	013612	Front Box Kit		4
	2	003619	Rear Leaf Spring		5
	4	4033	5/8 x 3-5/8 x 12" Round U-bolt		6
	1	55415	Single 5500 Steering Stabilizer		
	2	55750	Front 5500 Shock		
6" Front / 6" Rear 4-Link System Front Coil & 4-Link Rear Leaf Spring Kit #551H 76FK7992	1	033612	Front Coil Springs (Gas)		3
	1	013010	4-Link Kit Box 1 of 2		4
	1	013613	4-Link Kit Box 2 of 2		5
	2	003619	Rear Leaf Spring		6
	4	4033	5/8 x 3-5/8 x 12" Round U-bolt		
	1	55415	Single 5500 Steering Stabilizer		
8" Front / 8" Rear 4-Link System Front Coil & 4-Link Rear Leaf Spring Kit #566H 86FK6403	1	033812	Front Coil Springs (Gas)		3
	1	013810	4-Link Kit Box 1 of 2		4
	1	013812	4-Link Kit Box 2 of 2		5
	2	003829	Rear Leaf Spring		6
	1	55415	Single 5500 Steering Stabilizer		
	2	55751	Front 5500 Shock		

Notes

1. Removal of factory block required.
2. This listing will give a tail low stance of approximately 3".
3. Front exhaust modification may be required to clear front driveshaft.
4. Bumper spacer kit #123020 required to run 38" tires.
5. Although extremely rare, front driveline vibration may occur.
6. If equipped with 2-piece driveshaft, a Carrier Bearing Drop Kit may be required.

Vehicle Specs:
8" Lift Kit
38" Nitto M/T
20" XD Rockstar

2005-2007 FORD F-250, F-350 SUPER DUTY 4WD DIESEL PRO-RIDE SYSTEM



2005-2007 FORD F-250, F-350 SUPER DUTY DIESEL ONLY 4WD

Lift & Method	Qty	Part#	Description	Recommended Accessories	Notes
1" Front / 0" Rear Standard Kit Kit #325H 29FK152	1	013101	Front Coil Mounts	98224710	
	2	55710	Front 5500 Shock	98224660	
	2	55660	Rear 5500 Shock	55309	
2" Front / 0" Rear Standard Kit Kit #326H 41FK903	1	013201	Front Coil Mounts	55415	FOX 2.0 Front Gas Shock (2 req'd) FOX 2.0 Rear Gas Shock (2 req'd) Single Stabilizer Mounting Kit Single 5500 Steering Stabilizer <i>or</i> Single 9500 Steering Stabilizer
	2	55710	Front 5500 Shock	95415	
	2	55660	Rear 5500 Shock	123202	
4" Front / 3" Rear Standard Kit Front Coil & Bracket Kit Rear Block Kit w/o top ovl Kit #343H w/ top ovl Kit #344H 22FK8911	1	033411	Front Coil Springs (Diesel)	123402	Carrier Bearing Drop Kit FOX 2.0 Front Gas Shock (2 req'd) FOX 2.0 Rear Gas Shock (2 req'd) Dual Stabilizer Mounting Kit Dual 5500 Steering Stabilizer <i>or</i> Dual 9500 Steering Stabilizer Front Dual Shock Hoop Kit Dual 5500 Front Shocks (4 req'd) FOX 2.0 Dual Gas Shock (4 req'd) Adjustable Track Bar
	1	013411	Front Box Kit	98224700	
	1	013329	Rear Block Kit w/o top overload <i>or</i>	98224760	
	1	013328	Rear Block Kit w/ top overload	55358	
	1	55415	Single 5500 Steering Stabilizer	55405	
	2	55700	Front 5500 Shock	95405	
4" Front / 3" Rear 4-Link System Front Coil & Bracket Kit Rear Block Kit w/o top ovl Kit #345H w/ top ovl Kit #346H 20FK9402	1	033411	Front Coil Springs (Diesel)	123013	Adjustable Track Bar
	1	013010	4-Link Kit Box 1 of 2	55759	
	1	013011	4-Link Kit Box 2 of 2	98224759	
	1	013329	Rear Block Kit w/o top overload <i>or</i>	123202	
	1	013328	Rear Block Kit w/ top overload		
	1	55415	Single 5500 Steering Stabilizer		
4" Front / 4" Rear Standard Kit Front Coil & Bracket Kit Rear Leaf Springs Kit #347H 48FK4961	1	033411	Front Coil Springs (Diesel)		1 5 6
	1	013411	Front Box Kit		
	2	003609	Rear Leaf Spring		
	4	4032	5/8 x 3-5/8 x 10" Round U-Bolt		
	1	55415	Single 5500 Steering Stabilizer		
	2	55700	Front 5500 Shock		
4" Front / 4" Rear 4-Link System Front Coil & Bracket Kit Rear Leaf Springs Kit #348H 46FK5452	1	033411	Front Coil Springs (Diesel)		2 5 6
	1	013010	4-Link Kit Box 1 of 2		
	1	013011	4-Link Kit Box 2 of 2		
	2	003609	Rear Leaf Spring		
	4	4032	5/8 x 3-5/8 x 10" Round U-Bolt		
	1	55415	Single 5500 Steering Stabilizer		
4-Link Upgrade Kit #123011/123012.....89FK4301	2	55700	Front 5500 Shock		
	2	55760	Rear 5500 Shock		
	2	55760	Rear 5500 Shock		

See Notes ►

Continued ►

2005-2007 FORD F-250, F-350 SUPER DUTY 4WD DIESEL PRO-RIDE SYSTEM

CHEVROLET/
GMC

DODGE

FORD

JEEP

SUZUKI

TOYOTA

POSI-LOK

SHOCKS/
STEERING
STABILIZERS

APPAREL/
PROMOTIONAL

PRODUCT
SPECS

VEHICLE
SPECS

2005-2007 FORD F-250, F-350 SUPER DUTY DIESEL ONLY 4WD (CONTINUED)

Lift & Method	Qty	Part#	Description	Recommended Accessories	Notes			
6" Front / 4.5" Rear Standard Kit Front Coil & Bracket Kit Rear Block & Add-A-Leaf w/o top ovlid Kit #353H w/ top ovlid Kit #354H 64FK0541	1	033611	Front Coil Springs (Diesel)	SHOCKS 98224750 FOX 2.0 Front Gas Shock - 6" kit (2 req'd) 98224751 FOX 2.0 Front Gas Shock - 8" kit (2 req'd) 98224760 FOX 2.0 Rear Gas Shock - 6" kit (2 req'd) 98224765 FOX 2.0 Rear Gas Shock - 8" kit (2 req'd) 123013 Front Dual Shock Hoop Kit 55769 Dual 5500 Front Shocks - 6" kit (4 req'd) or 98224769 FOX 2.0 Dual Gas Shock - 6" kit (4 req'd) 55761 Dual 5500 Front Shocks - 8" kit (4 req'd) or 98224761 FOX 2.0 Dual Gas Shock - 8" kit (4 req'd) STABILIZERS 55358 Dual Steering Stabilizer Mounting Kit 55405 Dual 5500 Steering Stabilizer or 95405 Dual 9500 Steering Stabilizer T-CASE/DRIVELINE MODIFICATION 123402 Carrier Bearing Drop Kit - 6" kit 123406 Carrier Bearing Drop Kit - 8" kit or 123402 Carrier Bearing Drop Kit - 8" kit (Shims) ACCESSORIES 123202 Adjustable Track Bar	1	013611	Front Box Kit	1
	1	013329	Rear Block Kit w/o top overload or		4			
	1	013328	Rear Block Kit w/ top overload		5			
	1	113218	Add-A-Leaf		6			
	1	55415	Single 5500 Steering Stabilizer					
	2	55750	Front 5500 Shock					
	2	55760	Rear 5500 Shock					
	6" Front / 4.5" Rear 4-Link System Front Coil & Bracket Kit Rear Block & Add-A-Leaf w/o top ovlid Kit #355H w/ top ovlid Kit #356H 10FK5512	1	033611		Front Coil Springs (Diesel)			
1		013010	4-Link Kit Box 1 of 2					
1		013011	4-Link Kit Box 2 of 2					
1		013329	Rear Block Kit w/o top overload or					
1		013328	Rear Block Kit w/ top overload					
1		113218	Add-A-Leaf					
1		55415	Single 5500 Steering Stabilizer					
2		55750	Front 5500 Shock					
6" Front / 6" Rear Standard Kit Front Coil & Bracket Kit Rear Leaf Springs Kit #357H 88FK8581	1	033611	Front Coil Springs (Diesel)					
	1	013611	Front Box Kit					
	2	003609	Rear Leaf Spring					
	4	4033	5/8 x 3-5/8 x 12" Round U-Bolt					
	1	55415	Single 5500 Steering Stabilizer					
	2	55750	Front 5500 Shock					
	2	55760	Rear 5500 Shock					
	6" Front / 6" Rear 4-Link System Front Coil & Bracket Kit Rear Leaf Springs Kit #358H 34FK3652	1	033611	Front Coil Springs (Diesel)				
1		013010	4-Link Kit Box 1 of 2					
1		013011	4-Link Kit Box 2 of 2					
2		003609	Rear Leaf Spring					
4		4033	5/8 x 3-5/8 x 12" Round U-Bolt					
1		55415	Single 5500 Steering Stabilizer					
2		55750	Front 5500 Shock					
2		55760	Rear 5500 Shock					
8" Front / 8" Rear 4-Link System Front Coil & Bracket Kit Rear Leaf Springs Kit #530H 00FK9862	1	033811	Front Coil Springs (Diesel)		5			
	1	013810	4-Link Kit Box 1 of 2		6			
	1	013811	4-Link Kit Box 2 of 2					
	2	003809	Rear Leaf Spring					
	1	55415	Single 5500 Steering Stabilizer					
	2	55751	Front 5500 Shock					
	2	55765	Rear 5500 Shock					



Notes

1. If equipped with top mounted overload or optional 3-7/8" rear block, use rear box kit #013318.
2. Removal of O.E. block in the rear is required.
3. Do not install the 4" rear block kit if subject vehicle is equipped with factory 3-7/8" stock block. Use rear spring option only.
4. For tail high stance, use 013419, 013418 in place of 3" block kit. Note: This can only be done on vehicles with a stock 2" block.
5. Front dual shock hoop requires different cylinders than what comes in the base kit.
6. If equipped with 2 piece driveshaft, a Carrier Bearing Drop Kit may be required.



#343H - 4" Standard Kit



4-Link Upgrade Kit

- Upgrade your standard kit to a 4-link system for superior handling and on/off road performance
- Works on 2-6" lift kits

#123011/123012 89FK4301

2005-2007 FORD F-250, F-350 SUPER DUTY 4WD GAS PRO-RIDE SYSTEM

DODGE

FORD

JEEP

SUZUKI

TOYOTA

POSI-LOK

SHOCKS/
STEERING
STABILIZERS

APPAREL/
PROMOTIONAL

PRODUCT
SPECS

VEHICLE
SPECS



Standard Kit Features

- Heavy-duty track bar relocation bracket to properly center the axle
- Radius arm drop brackets designed to restore O.E. caster
- Pitman arm included to correct steering angles
- Sway bar and bump stop drops included for proper function
- Rear blocks or Glide-Ride rear leaf springs available, add-a-leaf available on 6" kit only
- Steering stabilizer bracket (cylinders sold separately)

4-Link System Features

- Heavy-duty, greaseable 4-link system offers less than 1° of caster change through full wheel travel
- Replacement frame brackets mount to existing frame holes—no drilling or welding required
- Utilizes oversized, greaseable, urethane control arm bushings
- Sway bar and bump stop drops included
- Pitman arm included for steering correction
- Heavy-duty track bar relocation bracket to properly center the axle
- Steering stabilizer bracket cylinder sold separately

8" 4-Link System Features

- The 8" system includes similar components to the 4" & 6" 4-Link system with longer control arms and Kevlar lined stainless steel brake lines.

2005-2007 FORD F-250, F-350 SUPER DUTY 4WD - GAS

Lift & Method	Qty	Part#	Description	Recommended Accessories	Notes
1" Front / 0" Rear Front Coil Mount Kit #325H 29FK152	1	013101	Front Coil Mounts	98224710	
	2	55710	Front 5500 Shock	98224660	
	2	55660	Rear 5500 Shock	55309 55415 95415	
2" Front / 0" Rear Front Coil Mount Kit #326H 41FK903	1	013201	Front Coil Mounts	123202	Adjustable Track Bar
	2	55710	Front 5500 Shock		
	2	55660	Rear 5500 Shock		
4" Front / 3" Rear Standard Kit Front Coil & Bracket Kit Rear Block Kit w/o top ovlid Kit #327H w/ top ovlid Kit #328H 43FK1021	1	033412	Front Coil Springs (Gas)	123402	Carrier Bearing Drop Kit FOX 2.0 Front Gas Shock (2 req'd) FOX 2.0 Rear Gas Shock (2 req'd) Dual Stabilizer Mounting Kit Dual 5500 Steering Stabilizer or Dual 9500 Steering Stabilizer Front Dual Shock Hoop Kit Dual 5500 Front Shocks (4 req'd) FOX 2.0 Dual Gas Shock (4 req'd) Adjustable Track Bar
	1	013411	Front Box Kit	98224700	
	1	013329	Rear Block Kit w/o top overload or	98224760	
	1	013328	Rear Block Kit w/ top overload	55358	
	1	55415	Single 5500 Steering Stabilizer	55405	
	2	55700	Front 5500 Shock	95405	
4" Front / 3" Rear 4-Link System Front Coil & Bracket Kit Rear Block Kit w/o top ovlid Kit #329H w/ top ovlid Kit #330H 41FK2502	1	033412	Front Coil Springs (Gas)	123013	
	1	013010	4-Link Kit Box 1 of 2	55759	
	1	013011	4-Link Kit Box 2 of 2	98224759	
	1	013329	Rear Block Kit w/o top overload or	123202	
	1	013328	Rear Block Kit w/ top overload		
	1	55415	Single 5500 Steering Stabilizer		
4" Front / 4" Rear Standard Kit Front Coil & Bracket Kit Rear Leaf Springs Kit #331H 69FK7961	1	033412	Front Coil Springs (Gas)		2 5 6
	1	013411	Front Box Kit		
	2	003609	Rear Leaf Spring		
	4	4032	5/8 x 3-5/8 x 10" Round U-Bolt		
	1	55415	Single 5500 Steering Stabilizer		
	2	55700	Front 5500 Shock		
4" Front / 4" Rear 4-Link System Front Coil & Bracket Kit Rear Leaf Springs Kit #332H 67FK8452	1	033412	Front Coil Springs (Gas)		
	1	013010	4-Link Kit Box 1 of 2		
	1	013011	4-Link Kit Box 2 of 2		
	2	003609	Rear Leaf Spring		
	4	4032	5/8 x 3-5/8 x 10" Round U-Bolt		
	1	55415	Single 5500 Steering Stabilizer		
4-Link Upgrade Kit • Upgrade your standard kit to a 4-link system for superior handling and on/off road performance • Works on 2-6" lift kits #123011/123012.....89FK4301	2	55700	Front 5500 Shock		
	2	55760	Rear 5500 Shock		



See Notes ►

Continued ►

2005-2007 FORD F-250, F-350 SUPER DUTY 4WD GAS PRO-RIDE SYSTEM

CHEVROLET/
GMC

DODGE

FORD

JEEP

SUZUKI

TOYOTA

POSI-LOK

SHOCKS/
STEERING
STABILIZERS

APPAREL/
PROMOTIONAL

PRODUCT
SPECS

VEHICLE
SPECS



Shown in gray, available in black only.

4-Link System Features

- Frame mounting bracket replaces OE bracket to increase ground clearance vs. a standard drop kit
- Less than 1 degree caster change through wheel travel giving you better on and offroad control
- Massive 2.5" O.D., greaseable, urethane control arm bushings
- 2" O.D. x 0.250" wall DOM tubing is used to make these extremely rugged control arms



2005-2007 FORD F-250, F-350 SUPER DUTY GAS ONLY 4WD (CONTINUED)

Lift & Method	Qty	Part#	Description	Recommended Accessories	Notes
6" Front / 4.5" Rear Standard Kit Front Coil & Bracket Kit Rear Block & Add-A-Leaf w/o top ovid Kit #337H w/ top ovid Kit #338H 85FK3541	1	033612	Front Coil Springs (Gas)	SHOCKS 98224750 FOX 2.0 Front Gas Shock - 6" kit (2 req'd) 98224751 FOX 2.0 Front Gas Shock - 8" kit (2 req'd) 98224760 FOX 2.0 Rear Gas Shock - 6" kit (2 req'd) 98224765 FOX 2.0 Rear Gas Shock - 8" kit (2 req'd) 123013 Front Dual Shock Hoop Kit 55769 Dual 5500 Front Shocks - 6" kit (4 req'd) or 98224769 FOX 2.0 Dual Gas Shock - 6" kit (4 req'd) 557619 Dual 5500 Front Shocks - 8" kit (4 req'd) or 98224761 FOX 2.0 Dual Gas Shock - 8" kit (4 req'd) 123008 Dual Rear Shock Mounting Kit - 6" kit 55760 Dual 5500 Shock - 6" kit (2 req'd) or 98224760 FOX 2.0 Rear Gas Shock - 6" kit (2 req'd) STABILIZERS 55358 Dual Steering Stabilizer Mounting Kit - 6" kit 55405 Dual 5500 Steering Stabilizer - 6" kit or 95405 Dual 9500 Steering Stabilizer - 6" kit 55368 Dual Steering Stabilizer Mounting Kit - 8" kit 55415 Dual 5500 Steering Stabilizer - 8" kit or 95415 Dual 9500 Steering Stabilizer - 8" kit T-CASE/DRIVELINE MODIFICATION 123402 Carrier Bearing Drop Kit - 6" kit 123406 Carrier Bearing Drop Kit - 8" kit or 123402 Carrier Bearing Drop Kit - 8" kit (Shims) ACCESSORIES 103001 Front SS Brake Line - 6" kit 103009 Rear SS Brake Line - 6" kit 123202 Adjustable Track Bar	1
	1	013611	Front Box Kit		4
	1	013329	Rear Block Kit w/o top overload or		5
	1	013328	Rear Block Kit w/ top overload		6
	1	113218	Add-A-Leaf		
	1	55415	Single 5500 Steering Stabilizer		
	2	55750	Front 5500 Shock		
6" Front / 4.5" Rear 4-Link System Front Coil & Bracket Kit Rear Block & Add-A-Leaf w/o top ovid Kit #339H w/ top ovid Kit #340H 31FK8512	1	033612	Front Coil Springs (Gas)		
	1	013010	4-Link Kit Box - 1 of 2		
	1	013011	4-Link Kit Box - 2 of 2		
	1	013329	Rear Block Kit- w/o top overload or		
	1	013328	Rear Block Kit w/ top overload		
	1	113218	Add-A-Leaf		
	1	55415	Single 5500 Steering Stabilizer		
6" Front / 6" Rear Standard Kit Front Coil & Bracket Kit Rear Leaf Springs Kit #341H 00FK2681	1	033612	Front Coil Springs (Gas)		
	1	013611	Front Box Kit		
	2	003609	Rear Leaf Spring		
	4	4033	5/8 x 3-5/8 x 12" Round U-Bolt		
	1	55415	Single 5500 Steering Stabilizer		
	2	55750	Front 5500 Shock		
	2	55760	Rear 5500 Shock		
6" Front / 6" Rear 4-Link System Front Coil & Bracket Kit Rear Leaf Springs Kit #342H 55FK6652	1	033612	Front Coil Springs (Gas)		
	1	013010	4-Link Kit Box - 1 of 2		
	1	013011	4-Link Kit Box - 2 of 2		
	2	003609	Rear Leaf Spring		
	4	4033	5/8 x 3-5/8 x 12" Round U-Bolt		
	1	55415	Single 5500 Steering Stabilizer		
	2	55750	Front 5500 Shock		
8" Front / 8" Rear 4-Link System Front Coil & Bracket Kit Rear Leaf Springs Kit #531H 00FK9862	1	033812	Front Coil Springs (Gas)		
	1	013810	4-Link Kit Box - 1 of 2		
	1	013811	4-Link Kit Box - 2 of 2		
	2	003809	Rear Leaf Spring		
	4	4033	5/8 x 3-5/8 x 12" Round U-Bolt		
	1	55415	Single 5500 Steering Stabilizer		
	2	55751	Front 5500 Shock		
2	55765	Rear 5500 Shock			

Notes

1. If equipped with top mounted overload or optional 3-7/8" rear block, use rear box kit #013318.
2. Removal of O.E. block in the rear is required.
3. Do not install the 4" rear block kit if subject vehicle is equipped with factory 3-7/8" stock block. Use rear spring option only.
4. For tail high stance, use 013419, 013418 in place of 3" block kit. Note: This should only be done on vehicles with a stock 2" block.
5. Front dual shock hoop requires different cylinders than what comes in the base kit.
6. If equipped with 2 piece driveshaft, a Carrier Bearing Drop Kit is required.



1999-2004 FORD F-250, F-350 SUPER DUTY

GLIDE-RIDE SYSTEM

DODGE

FORD

JEEP

SUZUKI

TOYOTA

POSI-LOK

SHOCKS/
STEERING
STABILIZERS

APPAREL/
PROMOTIONAL

PRODUCT
SPECS

VEHICLE
SPECS

1999-2000 FORD F-250, F-350 SUPER DUTY 4WD

Lift & Method	Qty	Part#	Description	Recommended Accessories	Notes
2.5" Front / 0" Rear	1	013251	Front Shackle Hanger Kit	98224660	FOX 2.0 Front Gas Shock (2 req'd)
Front Shackle & Hanger Kit	1	123002	1999 Front Sway Bar Links Kit or 2000 Front Sway Bar Links Kit	98224760	FOX 2.0 Rear Gas Shock (2 req'd)
1999 Kit #318H	2	55650	Front 5500 Shock	Page 128	Steering Stabilizers
2000 Kit #319H 80FK366	2	55660	Rear 5500 Shock	553001	Front Dual Shock Bracket Kit
				55660	Dual 5500 Shock (2 req'd) or
				98224660	FOX 2.0 Dual Gas Shock (2 req'd)
				123007	Rear Dual Shock Bracket Kit
				55760	Dual 5500 Shock (2 req'd) or
				98224760	FOX 2.0 Dual Gas Shock (2 req'd)
				123402	Carrier Bearing Drop Kit
				123005	Rear Anti-Sway Bar Link Kit

3/1/1999-2004 FORD F-250, F-350 SUPER DUTY 4WD WITH CURVED FRONT U-BOLTS

Lift & Method	Qty	Part#	Description	Recommended Accessories	Notes
2.5" Front / 0" Rear	2	003202	Front Leaf Spring	55405	Single 5500 Steering Stabilizer
Front Leaf Springs	1	013253	Front Box Kit	98224650	FOX 2.0 Front Gas Shock (2 req'd)
Kit #320H	2	55650	Front 5500 Shock	98224660	FOX 2.0 Rear Gas Shock (2 req'd)
06FK359	2	55660	Rear 5500 Shock		
4" Front / 3" Rear	2	003402	Front Leaf Spring	98224650	FOX 2.0 Front Gas Shock (2 req'd)
Front Leaf Springs	1	013405	Front Box Kit	98224760	FOX 2.0 Rear Gas Shock (2 req'd)
3" Rear Blocks	1	013329	Rear Kit w/ 3-5/8" Axle Tube w/o Top Mounted Over Load or Rear Kit w/ 3-5/8" Axle Tube with Top Mounted Over Load	Page 128	Steering Stabilizers
w/o top ovid Kit #321H	1	013328	Rear Kit w/ 3-5/8" Axle Tube with Top Mounted Over Load	553001	Front Dual Shock Bracket Kit
w/ top ovid Kit #322H	2	55650	Front 5500 Shock	55650	Dual 5500 Shock (2 req'd) or
93FK7421	2	55760	Rear 5500 Shock	98224650	FOX 2.0 Dual Gas Shock (2 req'd)
				123007	Rear Dual Shock Bracket Kit
				55760	Dual 5500 Shock (2 req'd) or
				98224760	FOX 2.0 Dual Gas Shock (2 req'd)
				123402	Carrier Bearing Drop Kit
6" Front / 4.5" Rear	2	003602	Front Leaf Spring	98224660	FOX 2.0 Front Gas Shock (2 req'd)
Front Leaf Springs	1	013006	Front Box Kit	98224760	FOX 2.0 Rear Gas Shock (2 req'd)
Rear Block & Add-A-Leaf	1	013329	Rear Kit w/ 3-5/8" Axle Tube w/o Top Mounted Over Load or Rear Kit w/ 3-5/8" Axle Tube with Top Mounted Over Load	Page 128	Steering Stabilizers
w/o top ovid Kit #1300H	1	013328	Rear Add-A-Leaf	553001	Front Dual Shock Bracket Kit
w/ top ovid Kit #1301H	1	113218	Rear Add-A-Leaf	55660	Dual 5500 Shock (2 req'd) or
38FK7841	2	55660	Front 5500 Shock	98224660	FOX 2.0 Dual Gas Shock (2 req'd)
	2	55760	Rear 5500 Shock	123007	Rear Dual Shock Bracket Kit
				55760	Dual 5500 Shock (2 req'd) or
				98224760	FOX 2.0 Dual Gas Shock (2 req'd)
6" Front / 6" Rear	2	003602	Front Leaf Spring	98224760	FOX 2.0 Dual Gas Shock (2 req'd)
Front Leaf Springs	2	003609	Rear Leaf Spring		
Rear Leaf Springs	1	013006	Front Box Kit	123402	Carrier Bearing Drop Kit
Kit #323H	1	013009	Rear Box Kit	123005	Rear Anti-Sway Bar Link Kit
23FK0981	2	55660	Front 5500 Shock		
	2	55760	Rear 5500 Shock		
8" Front / 8" Rear	2	003802	Front Leaf Spring	98224660	FOX 2.0 Front Gas Shock (2 req'd)
Front Leaf Springs	2	003809	Rear Leaf Spring	98224765	FOX 2.0 Rear Gas Shock (2 req'd)
Rear Leaf Springs	1	013006	Front Box Kit	Page 128	Steering Stabilizers
Kit #324H	1	013009	Rear Box Kit	553001	Front Dual Shock Bracket Kit
06FK9291	2	55660	Front 5500 Shock	55660	Dual 5500 Shock (2 req'd) or
	2	55765	Rear 5500 Shock	98224660	FOX 2.0 Dual Gas Shock (2 req'd)
				123007	Rear Dual Shock Bracket Kit
				55760	Dual 5500 Shock (2 req'd) or
				98224760	FOX 2.0 Dual Gas Shock (2 req'd)
				123406	Carrier Bearing Drop Kit
				123005	Rear Anti-Sway Bar Link Kit



Vehicle Specs:
8" Lift Kit
37" Kumho M/T
20 Halo Wheels

1999-2003 FORD F-250, F-350 SUPER DUTY GLIDE-RIDE SYSTEM

CHEVROLET/
GMC

DODGE

FORD

JEEP

SUZUKI

TOYOTA

POSI-LOK

SHOCKS/
STEERING
STABILIZERS

APPAREL/
PROMOTIONAL

PRODUCT
SPECS

VEHICLE
SPECS



#323H - 6" Full Leaf Kit

Rear Dual Shock Bracket Kit

#123007..... 67FK413



Note: Will not fit dually equipped vehicles or Excursion

3/1/1999-2003 FORD F-250, F-350 SUPER DUTY 4WD WITH SQUARE FRONT U-BOLTS							
Lift & Method	Qty	Part#	Description	Recommended Accessories		Notes	
2.5" Front / 0" Rear Front Leaf Springs Kit #313H 06FK359	2	003202	Front Leaf Spring	55405	Single 5500 Steering Stabilizer		2
	1	013252	Front Box Kit	98224650	FOX 2.0 Front Gas Shock (2 req'd)		4
	2	55650	Front 5500 Shock	98224660	FOX 2.0 Rear Gas Shock (2 req'd)		6
	2	55660	Rear 5500 Shock				
4" Front / 3" Rear Front Leaf Springs 3" Rear Block Kit w/o top ovlid Kit #314H w/ top ovlid Kit #315H 93FK7421	2	003402	Front Leaf Spring	98224650	FOX 2.0 Front Gas Shock (2 req'd)		1
	1	013404	Front Box Kit	98224760	FOX 2.0 Rear Gas Shock (2 req'd)		4
	1	013329	Rear Kit w/ 3-5/8" Axle Tube w/o Top Mounted Over Load or Rear Kit w/ 3-5/8" Axle Tube with Top Mounted Over Load	Page 128	Steering Stabilizers		5
	1	013328	Rear Kit w/ 3-5/8" Axle Tube with Top Mounted Over Load	553001	Front Dual Shock Bracket Kit		6
	2	55660	Front 5500 Shock	55660	Dual 5500 Shock (2 req'd) or FOX 2.0 Dual Gas Shock (2 req'd)		
	2	55760	Rear 5500 Shock	98224660	Rear Dual Shock Bracket Kit		
6" Front / 4.5" Rear Front Leaf Springs Rear Block & Add-A-Leaf w/o top ovlid Kit #1302H w/ top ovlid Kit #1303H 38FK7841	2	003602	Front Leaf Spring	98224660	FOX 2.0 Front Gas Shock (2 req'd)		1
	1	013005	Front Box Kit	98224760	FOX 2.0 Rear Gas Shock (2 req'd)		2
	1	013329	Rear Kit w/ 3-5/8" Axle Tube w/o Top Mounted Over Load or Rear Kit w/ 3-5/8" Axle Tube with Top Mounted Over Load	Page 128	Steering Stabilizers		3
	1	013328	Rear Add-A-Leaf	553001	Front Dual Shock Bracket Kit		4
	2	113218	Front 5500 Shock	55660	Dual 5500 Shock (2 req'd) or FOX 2.0 Dual Gas Shock (2 req'd)		5
	2	55760	Rear 5500 Shock	98224660	Rear Dual Shock Bracket Kit		6
6" Front / 6" Rear Front Leaf Springs Rear Leaf Springs Kit #316H 23FK0981	2	003602	Front Leaf Spring	123007	Rear Dual Shock Bracket Kit		1
	2	003609	Rear Leaf Spring	55760	Dual 5500 Shock (2 req'd) or FOX 2.0 Dual Gas Shock (2 req'd)		2
	1	013005	Front Box Kit	98224760	Carrier Bearing Drop Kit		3
	1	013009	Rear Box Kit	123402	Rear Anti-Sway Bar Link Kit		4
	2	55660	Front 5500 Shock	123005			5
	2	55760	Rear 5500 Shock				6
8" Front / 8" Rear Front Leaf Springs Rear Leaf Springs Kit #317H 06FK9291	2	003802	Front Leaf Spring	98224660	FOX 2.0 Front Gas Shock (2 req'd)		1
	2	003809	Rear Leaf Spring	98224765	FOX 2.0 Rear Gas Shock (2 req'd)		2
	1	013005	Front Box Kit	Page 128	Steering Stabilizers		3
	1	013009	Rear Box Kit	553001	Front Dual Shock Bracket Kit		4
	2	55660	Front 5500 Shock	55660	Dual 5500 Shock (2 req'd) or FOX 2.0 Dual Gas Shock (2 req'd)		5
	2	55765	Rear 5500 Shock	98224660	Rear Dual Shock Bracket Kit		6
				123007	Dual 5500 Shock (2 req'd) or FOX 2.0 Dual Gas Shock (2 req'd)		
				55765	Carrier Bearing Drop Kit		
			98224765	Rear Anti-Sway Bar Link Kit			
			123406				
			123005				

Notes

1. If equipped with a two-piece rear driveshaft order BDS #123402 or #123406.
2. The stock Super Duty came with a rear 2", 3", or 4" rear block. You may need to change the block and/or u-bolts in order to level the truck.
3. The front driveshaft will need to be lengthened and/or clearance ground depending on how the vehicle is equipped.
4. #003202, #003402, #003602, #003609, #003802, and #003809 come with OE rubber bushings installed.
5. Rear kits are for single wheel F-350 with Dana 70 only. Dual wheel F-350 with Dana 80 requires 3-7/8" wide u-bolts.
6. Confirm build date, front u-bolt type and rear leaf pack overload position before ordering.

UP TO 2/28/99 FORD F-250, F-350 SUPER DUTY GLIDE-RIDE SYSTEM

UP TO 2/28/1999 FORD F-250, F-350 SUPER DUTY 4WD

Lift & Method	Qty	Part#	Description	Recommended Accessories	Notes	
4" Front / 2.5" Rear Front Leaf Springs Rear Blocks w/o top ovlid Kit #309H w/ top ovlid Kit #310H 93FK7421	2	003402	Front Leaf Spring	98224650	FOX 2.0 Front Gas Shock (2 req'd) FOX 2.0 Rear Gas Shock (2 req'd) Page 128 Steering Stabilizers Front Dual Shock Bracket Kit Dual 5500 Shock (2 req'd) or FOX 2.0 Dual Gas Shock (2 req'd) 123007 Rear Dual Shock Bracket Kit Dual 5500 Shock (2 req'd) or FOX 2.0 Dual Gas Shock (2 req'd) 123402 Carrier Bearing Drop Kit	1 4 5 6
	1	013402	Front Box Kit	98224760		
	1	013329	Rear Kit w/ 3-5/8" Axle Tube w/o Top Mounted Over Load or	Page 128		
	1	013328	Rear Kit w/ 3-5/8" Axle Tube with Top Mounted Over Load	553001		
	2	55650	Front 5500 Shock	55650		
	2	55760	Rear 5500 Shock	98224650		
6" Front / 6" Rear Front Leaf Springs Rear Leaf Springs Kit #311H 90FK6781	2	003602	Front Leaf Spring	98224660	FOX 2.0 Front Gas Shock (2 req'd) FOX 2.0 Rear Gas Shock (2 req'd) Page 128 Steering Stabilizers Front Dual Shock Bracket Kit Dual 5500 Shock (2 req'd) or FOX 2.0 Dual Gas Shock (2 req'd) 123007 Rear Dual Shock Bracket Kit Dual 5500 Shock (2 req'd) or FOX 2.0 Dual Gas Shock (2 req'd) 123402 Carrier Bearing Drop Kit 123005 Rear Anti-Sway Bar Link Kit	1 2 3 4 5 6
	2	003609	Rear Leaf Spring	98224760		
	1	013004	Front Box Kit	Page 128		
	1	013009	Rear Box Kit	553001		
	2	55660	Front 5500 Shock	55660		
	2	55760	Rear 5500 Shock	98224660		
				123007		
				55760		
8" Front / 8" Rear Front Leaf Springs Rear Leaf Springs Kit #312H 73FK5191	2	003802	Front Leaf Spring	98224660	FOX 2.0 Front Gas Shock (2 req'd) FOX 2.0 Rear Gas Shock (2 req'd) Page 128 Steering Stabilizers Front Dual Shock Bracket Kit Dual 5500 Shock (2 req'd) or FOX 2.0 Dual Gas Shock (2 req'd) 123007 Rear Dual Shock Bracket Kit Dual 5500 Shock (2 req'd) or FOX 2.0 Dual Gas Shock (2 req'd) 123406 Carrier Bearing Drop Kit 123005 Rear Anti-Sway Bar Link Kit	1 2 3 4 5 6
	2	003809	Rear Leaf Spring	98224765		
	1	013004	Front Box Kit	Page 128		
	1	013009	Rear Box Kit	553001		
	2	55660	Front 5500 Shock	55660		
	2	55765	Rear 5500 Shock	98224660		
				123007		
				55765		

Notes

1. If equipped with a two-piece rear driveshaft order BDS #123402 or #123406.
2. The stock Super Duty came with a rear 2", 3", or 4" rear block. You may need to change the block and/or u-bolts in order to level the truck.
3. The front driveshaft will need to be lengthened and/or clearance ground depending on how the vehicle is equipped.
4. #003402, #003602, #003609, #003802, and #003809 come with OE rubber bushings installed.
5. Rear kits are for single wheel F-350 with Dana 70 only. Dual wheel F-350 with Dana 80 requires 3-7/8" wide u-bolts.
6. Confirm build date, front u-bolt type and rear leaf pack overload position before ordering.



4" F-250 Glide-Ride Suspension System



4" F-350 Glide-Ride Suspension System

1980-1996 FORD F-250 TTB FRONT AXLE 4WD

Lift & Method	Qty	Part#	Description	Recommended Accessories	Notes	
4" Front / 3" Rear Front Leaf Springs Rear 3" Block Kit '87-'96 Kit #306H '80-'86 Kit #307H 50FK3031	2	003401	Front Leaf Spring	Page 128	Steering Stabilizers Anti-Sway Bar Drop Kit Rear Leaf Spring 98224650 FOX Front Gas Shock (2 req'd) 98224660 FOX Rear Gas Shock (2 req'd)	1 2 4
	1	013401	Front Box Kit	123401		
	1	013309	Rear Box Kit	003408		
	2	55650	87-96 Front Shock or	98224650		
	2	55820	80-86 Front Shock	98224660		
	2	55660	Rear 5500 Shock			

1980-1996 FORD F-350 WITH MONOBEAM FRONT AXLE 4WD

Lift & Method	Qty	Part#	Description	Recommended Accessories	Notes	
4" Front / 3" Rear Front Leaf Springs Rear 3" Block Kit Kit #308H 18FK9501	2	003401	Front Leaf Spring	Page 128	Steering Stabilizers Anti-Sway Bar Drop Kit Rear Leaf Spring 98224650 FOX Front Gas Shock (2 req'd) 98224660 FOX Rear Gas Shock (2 req'd)	1 2 3
	1	013403	Front Box Kit	123401		
	1	013308	Rear Box Kit	003408		
	1	083401	Pitman Arm (PS)	98224650		
	2	55650	Front 5500 Shock	98224660		
	2	55660	Rear 5500 Shock			

Notes

1. Not recommended for diesel applications.
2. #003401 comes with OE rubber bushings installed.
3. Optional pitman arm listed for vehicles with Dana 44 only.
4. Pitman arm included in the #013401 Front Box Kit.

2000-2005 FORD EXCURSION GLIDE-RIDE SYSTEM

CHEVROLET/
GMC

DODGE

FORD

JEEP

SUZUKI

TOYOTA

POSI-LOK

SHOCKS/
STEERING
STABILIZERS

APPAREL/
PROMOTIONAL

PRODUCT
SPECS

VEHICLE
SPECS



Vehicle Specs:
8" Lift Kit
37" Nitto M/T
20" RBP 91R

2000-2005 FORD EXCURSION 4WD

Lift & Method	Qty	Part#	Description	Recommended Accessories	Notes	
4" Front / 3" Rear	2	003202	Front Leaf Spring	98224650	FOX 2.0 Front Gas Shock (2 req'd)	1
Front Leaf Springs	1	013253	Front Box Kit	98224762	FOX 2.0 Rear Gas Shock (2 req'd)	2
Rear Block Kit	1	013329	Rear 5" Block Kit	55405	Single 5500 Steering Stabilizer	6
Kit #300H	2	55650	Front 5500 Shock	553001	Front Dual Shock Bracket Kit	7
86FK5901	2	55762	Rear 5500 Shock	55650	Dual 5500 Shock (2 req'd) or	8
4" Front / 4" Rear	2	003202	Front Leaf Spring	98224650	FOX 2.0 Dual Gas Shock (2 req'd)	
Front Leaf Springs	1	013253	Front Box Kit	123004	Rear Sway Bar Links 13.5" long	
Rear Leaf Springs	2	003609	Rear Leaf Spring			
Kit #301H	1	013009	Rear Box Kit			
73FK6851	2	55650	Front 5500 Shock			
	2	55762	Rear 5500 Shock			
6" Front / 5" Rear	2	003402	Front Leaf Spring	98224650	FOX 2.0 Front Gas Shock (2 req'd)	1
Front Leaf Spring	1	013405	Front Box Kit	98224762	FOX 2.0 Rear Gas Shock (2 req'd)	2
5" Rear Block Kit & Rear Add-A-Leaf	1	069509	Rear 5" Block Kit	Page 128	Steering Stabilizers	6
Kit #302H	1	113206	Rear Add-A-Leafs	553001	Front Dual Shock Bracket Kit	7
68FK8721	4	4034	5/8 x 3-5/8 x 15" U-Bolt	55650	Dual 5500 Shock (2 req'd) or	
	2	55650	Front 5500 Shock	98224650	FOX Dual Gas Cylinder (2 req'd)	
	2	55762	Rear 5500 Shock	123005	Rear Sway Bar Links	
6" Front / 6" Rear	2	003402	Front Leaf Spring			2
Front Leaf Springs	2	003609	Rear Leaf Spring			5
Rear Leaf Springs	1	013405	Front Box Kit			6
Kit #303H	1	013009	Rear Box Kit			7
80FK8371	2	55650	Front 5500 Shock			
	2	55762	Rear 5500 Shock			
8" Front / 8" Rear	2	003602	Front Leaf Spring	98224660	FOX 2.0 Front Gas Shock	2
Front Leaf Springs	2	003809	Rear Leaf Spring	98224766	FOX 2.0 Rear Gas Shock	3
Rear Leaf Springs	1	013006	Front Box Kit	Page 128	Steering Stabilizers	5
Kit #304H	1	013009	Rear Box Kit	553001	Front Dual Shock Bracket Kit	6
23FK0981	2	55660	Front 5500 Shock	55660	Dual 5500 Shock (2 req'd) or	7
	2	55762	Rear 5500 Shock	98224660	FOX 2.0 Dual Gas Shock	
10" Front / 10" Rear	2	003802	Front Leaf Spring	123005	Rear Sway Bar Links	1
Front Leaf Springs	2	003809	Rear Leaf Spring			2
Rear Leaf Springs	1	013006	Front Box Kit			3
Kit #305H	1	013007	Rear Box Kit			4
14FK4791	2	55660	Front 5500 Shock			5
	2	55766	Rear 5500 Shock			6
						7

Notes

1. Remove factory block.
2. Models with rear CV driveshaft may experience drive line vibration.
3. Front and rear driveshaft modification will be required.
4. #013007 includes a 4" block to replace the stock 2" block.
5. Due to OE variances, you may need to change the rear block to level the truck.
6. #003202, #003402, #003602, #003609, #003802 & #003809 come with rubber bushings installed.
7. A truck leaf spring will give 2" of additional lift when installed on an Excursion.
8. Gas models may require add-a-leaf kit (113206) to better level the vehicle.

JEEP





2" Spacer Kit

- Polyurethane coil spring spacers retain OE ride quality
- Front and rear bump stops
- Rear brake line relocation kit
- Choice of BDS 5500 or FOX 2.0 Shocks



2" System Includes

- Front and rear Pro-Ride coils
- Front and rear bump stops
- Front lower octocam lock kit included
- Rear brake line relocation



3" System Includes

- Front and rear Pro-Ride coils
- Front sway bar ultimate disconnects, for links
- Rear track bar relocation
- Front and rear bump stop extensions
- Brake line extensions
- Choice of BDS 5500 or FOX 2.0 Shocks
- Front lower octocam lock kit included



Exhaust Spacers
for 2012-2014 JK

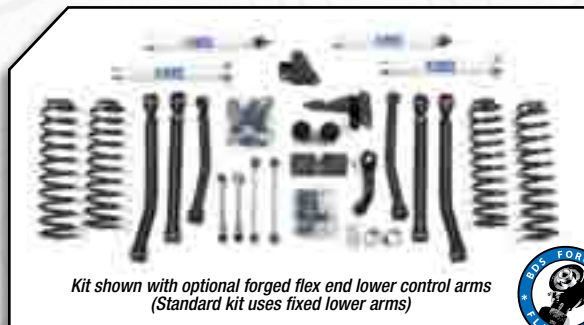

Kit shown with optional forged flex end lower control arms
(Standard kit uses fixed lower arms)



4" - 4.5" System Includes

- Front and rear Pro-Ride coils capable of full coil bind
- Front ultimate sway bar disconnects and rear solid links
- Front track bar relocation designed to work with the new dropped pitman arm
- Front lower control arms included to restore caster
- Rear upper adjustable and lower fixed arms to properly center the axle in the wheel well and allow for pinion adjustment
- Front and rear bump stop extensions
- Rear track bar relocation to properly center the axle
- Choice of BDS 5500 or FOX 2.0 Shocks



4" - 6.5" Long Arm System Include

- Long Arm 4-Link geometry offers superior on and off road control
- 1/4" steel 4-Link mounting brackets utilizing BDS multi-mount system
- Pro-Ride coils capable of being fully compressed and always coming back to original height
- Fully adjustable upper and lower heavy wall tubular control arms with Clevite rubber bushings and forged flex ends
- Front ultimate sway bar disconnects, rear sway bar brackets for easy one handed operation, rear sway bar brackets
- Front and rear track bar bracket or available Adjustable Track Bars
- Front and rear stainless, braided, Kevlar lined brake lines
- Choice of BDS 5500 or FOX 2.0 Shocks

2012-2014 JEEP WRANGLER JK 4 DOOR

PRO-RIDE SYSTEM

Vehicle Specs:
4.5" Long Arm Kit
35" D/C FC-II
17" Ballistic Jester



2012-2014 JEEP WRANGLER JK 4-DOOR - 4WD

Lift & Method	Qty	Part#	Description	Recommended Accessories	Notes
2" Front/2" Rear Front Coil Spacers Rear Coil Spacers Kit #463H 43JK423	1	024203	Spring Spacer Kit	SHOCKS 98224921 FOX 2.0 Front Gas Shock - 3" kit (2 req'd) 98224931 FOX 2.0 Rear Gas Shock - 3" kit (2 req'd)	4 5
	2	55710	Front 5500 Shock		
	2	55951	Rear 5500 Shock		
2" Front/2" Rear Front Coil Springs Rear Coil Springs Kit #1430H 15JK075	1	034202	Front Coil Springs	STABILIZERS 55421 Single 5500 Steering Stabilizer <i>or</i> 95421 Single 9500 Steering Stabilizer	5
	1	034209	Rear Coil Springs		
	1	124320	Front Sway Bar Links		
	1	124314	JK Exhaust Kit		
	2	55700	Front 5500 Shock		
3" Front/3" Rear Front Coil Springs Rear Coil Springs Std Kit #1403H 41JK957 Rubicon Kit #1404H 05JK466	1	034311	Front Coil Springs	TRACK BARS 124403 Front Adjustable Track Bar 124308 Rear Track Bar Bracket <i>or</i> 124408 Rear Adjustable Track Bar	1 7
	1	034319	Rear Coil Springs		
	1	014312	Complete Box Kit		
	1	124310	Front Sway Bar Disconnects <i>or</i> Front Sway Bar Links (Rubicon)		
	1	124314	JK Exhaust Kit		
	2	55700	Front 5500 Shock		
	2	55951	Rear 5500 Shock		
4.5" Front/4" Rear Front Coil Springs Rear Coil Springs Std Kit #1405H 52JK3841 Rubicon Kit #1406H 16JK8831	1	034411	Front Coil Springs	ACCESSORIES Page 135 Control Arms 124310 Ultimate Swaybar Disconnects - 2" kit 2034 JKS Quicker Disconnect 124330 Octo Cam Alignment Kit	1 2 7
	1	034419	Rear Coil Springs		
	1	014446	Complete Box Kit		
	1	124310	Front Sway Bar Disconnects <i>or</i> Front Sway Bar Links (Rubicon)		
	1	124320	Front Sway Bar Links (Rubicon)		
	1	124314	JK Exhaust Kit		
	1	124331	Front Lower Fixed Control Arms		
	1	124339	Rear Lower Fixed Control Arms		
	2	55700	Front 5500 Shock		
	2	55959	Rear 5500 Shock		
4.5" Front/4" Rear Front Long Arm 4-Link Rear Long Arm 4-Link Std Kit #1407H 00JK7872 Rubicon Kit #1408H 58JK4072	1	014691	Front Arm Box Kit	SHOCKS 98224921 FOX 2.0 Front Gas Shock - 4.5" SA kit (2 req'd) 98224922 FOX 2.0 Front Gas Shock - 4.5" LA kit (2 req'd) 98224959 FOX 2.0 Rear Gas Shock - 4.5" kit (2 req'd) 98224952 FOX 2.0 Front Gas Shock - 6.5" kit (2 req'd) 98224958 FOX 2.0 Rear Gas Shock - 6.5" kit (2 req'd)	1 3 7
	1	014689	Rear Arm Box Kit		
	1	014493	Main Box Kit		
	1	034411	Front Coil Springs		
	1	034419	Rear Coil Springs		
	1	124603	Front Sway Bar Disconnects <i>or</i> Front Sway Bar Links (Rubicon)		
	1	124321	Front Sway Bar Links (Rubicon)		
	2	55922	Front 5500 Shock		
	2	55959	Rear 5500 Shock		
	6.5" Front/6" Rear Front Long Arm 4-Link Rear Long Arm 4-Link Std Kit #1409H 10JK8482 Rubicon Kit #1410H 68JK5672	1	014691		
1		014689	Rear Arm Box Kit		
1		014690	Main Box Kit		
1		124603	Front Sway Bar Disconnects <i>or</i> Front Sway Bar Links (Rubicon)		
1		124321	Front Sway Bar Links (Rubicon)		
1		034611	Front Coil Springs		
1		034619	Rear Coil Springs		
2		55952	Front 5500 Shock		
2		55958	Rear 5500 Shock		
6.5" Front/6" Rear Front Long Arm 4-Link Rear Long Arm 4-Link Std Kit #1409H 10JK8482 Rubicon Kit #1410H 68JK5672		1	014691	Front Arm Box Kit	TRACK BARS 124403 Front Adjustable Track Bar 124408 Rear Track Bar Bracket
	1	014689	Rear Arm Box Kit		
	1	014690	Main Box Kit		
6.5" Front/6" Rear Front Long Arm 4-Link Rear Long Arm 4-Link Std Kit #1409H 10JK8482 Rubicon Kit #1410H 68JK5672	1	124603	Front Sway Bar Disconnects <i>or</i> Front Sway Bar Links (Rubicon)	ACCESSORIES Page 135 4.5" Adjustable Control Arms 2034 JKS Quicker Disconnect	1 6 7
	1	124321	Front Sway Bar Links (Rubicon)		
	1	034611	Front Coil Springs		
6.5" Front/6" Rear Front Long Arm 4-Link Rear Long Arm 4-Link Std Kit #1409H 10JK8482 Rubicon Kit #1410H 68JK5672	1	034619	Rear Coil Springs		
	2	55952	Front 5500 Shock		
	2	55958	Rear 5500 Shock		

Notes:

- Will not fit 2wd models.
- The fixed front and rear lower control arms can be upgraded to the flex or adjustable arms listed in the accessories.
- The front driveshaft is maxed out at full droop and on certain models the driveshaft boot can contact the transmission pan. Replacement of the front driveshaft is recommended.
- Removing the OE spring isolators will result in a 1" lift if desired.
- 124408 rear track bar or 124308 rear track bar relocation is recommended if using factory wheels.
- The front and rear driveshafts are maxed out at full droop. The front driveshaft boot can contact the transmission pan at extreme articulation on some models. Replacement of the front and rear driveshafts is recommended.
- Exhaust modification may be required.

2012-2014 JEEP WRANGLER JK 2 DOOR PRO-RIDE SYSTEM

CHEVROLET/
GMC

DODGE

FORD

JEEP

SUZUKI

TOYOTA

POSI-LOK

SHOCKS/
STEERING
STABILIZERS

APPAREL/
PROMOTIONAL

PRODUCT
SPECS

VEHICLE
SPECS



Vehicle Specs:
4" Lift Kit
35" M/T MTZ
17" D/C DC2

2012-2014 JEEP WRANGLER JK 2-DOOR - 4WD

Lift & Method	Qty	Part#	Description	Recommended Accessories	Notes
2" Front/2" Rear	1	024203	Spring Spacer Kit	SHOCKS	4
Front Coil Spacers	2	55710	Front 5500 Shock	98224921 FOX 2.0 Front Gas Shock - 3" kit (2 req'd)	5
Rear Coil Spacers	2	55951	Rear Shock	98224931 FOX 2.0 Rear Gas Shock - 3" kit (2 req'd)	
Kit #463H 43JK423				STABILIZERS	
2" Front/2" Rear	1	024203	Spring Spacer Kit	55421 Single 5500 Steering Stabilizer or	4
Front Coil Spacers	1	124320	Front Sway Bar Links	95421 Single 9500 Steering Stabilizer	5
Rear Coil Spacers	1	124314	JK Exhaust Kit		
Kit #1429H	2	55700	Front 5500 Shock	TRACK BARS	
14JK814	2	55951	Rear 5500 Shock	124403 Front Adjustable Track Bar	
3" Front/3" Rear	1	034312	Front Coil Springs	124308 Rear Track Bar Bracket or	1
Front Coil Springs	1	034209	Rear Coil Springs	124408 Rear Adjustable Track Bar	7
Rear Coil Springs	1	014312	Complete Box Kit		
Std Kit #1415H	1	124310	Front Sway Bar Disconnects or	ACCESSORIES	
41JK857	1	124320	Front Sway Bar Links (Rubicon)	Page 135 Control Arms	
Rubicon Kit #1416H	1	124314	JK Exhaust Kit	124310 Ultimate Swaybar Disconnects - 2" kit	
05JK366	2	55700	Front 5500 Shock	2034 JKS Quicker Disconnect	
	2	55951	Rear 5500 Shock	124330 Octo Cam Alignment Kit	
4" Front/4" Rear	1	034311	Front Coil Springs	SHOCKS	1
Front Coil Springs	1	034319	Rear Coil Springs	98224921 FOX 2.0 Front Gas Shock - 4.5" SA kit (2 req'd)	2
Rear Coil Springs	1	014446	Complete Box Kit	98224922 FOX 2.0 Front Gas Shock - 4.5" LA kit (2 req'd)	7
Std Kit #1417H	1	124310	Front Sway Bar Disconnects or	98224959 FOX 2.0 Rear Gas Shock - 4.5" kit (2 req'd)	
52JK3841	1	124320	Front Sway Bar Links (Rubicon)	98224952 FOX 2.0 Front Gas Shock - 6.5" kit (2 req'd)	
Rubicon Kit #1418H	1	124314	JK Exhaust Kit	98224958 FOX 2.0 Rear Gas Shock - 6.5" kit (2 req'd)	
16JK8831	1	124331	Front Lower Fixed Control Arms	STABILIZERS	
	1	124339	Rear Lower Fixed Control Arms	55401 Single 5500 Steering Stabilizer or	1
	2	55700	Front 5500 Shock	95421 Single 9500 Steering Stabilizer	3
	2	55959	Rear 5500 Shock	55366 Dual Steering Stabilizer Mount Kit	7
4" Front/4" Rear	1	014691	Front Arm Box Kit	55405 Dual 5500 Steering Stabilizer (2 req'd) or	
Front Long Arm 4-Link	1	014689	Rear Arm Box Kit	95405 Dual 5500 Steering Stabilizer (2 req'd)	
Rear Long Arm 4-Link	1	014493	Main Box Kit	TRACK BARS	
Std Kit #1419H	1	034311	Front Coil Springs	124403 Front Adjustable Track Bar	
00JK7872	1	034319	Rear Coil Springs	124408 Rear Track Bar Bracket	
Rubicon Kit #1420H	1	124603	Front Sway Bar Disconnects or	ACCESSORIES	1
58JK4072	1	124321	Front Sway Bar Links	Page 135 4" Adjustable Control Arms	6
	2	55922	Front 5500 Shock	2034 JKS Quicker Disconnect	7
	2	55959	Rear 5500 Shock		
5.5" Front/5" Rear	1	014691	Front Arm Box Kit		
Front Long Arm 4-Link	1	014689	Rear Arm Box Kit		
Rear Long Arm 4-Link	1	014690	Main Box Kit		
Std Kit #1421H	1	124603	Front Sway Bar Disconnects or		
12JK7082	1	124321	Front Sway Bar Links		
Rubicon Kit #1422H	1	034411	Front Coil Springs		
60JK5272	1	034419	Rear Coil Springs		
	2	55922	Front 5500 Shock		
	2	55958	Rear 5500 Shock		

Notes:

- Will not fit 2wd models.
- The fixed front and rear lower control arms can be upgraded to the flex or adjustable arms listed in the accessories.
- The front driveshaft is maxed out at full droop and on certain models the driveshaft boot can contact the transmission pan. Replacement of the front driveshaft is recommended.
- Removing the OE spring isolators will result in a 1" lift if desired.
- 124408 rear track bar or 124308 rear track bar relocation is recommended if using factory wheels.
- The front and rear driveshafts are maxed out at full droop. The front driveshaft boot can contact the transmission pan at extreme articulation on some models. Replacement of the front and rear driveshafts is recommended.
- Exhaust modification may be required.

2007-2011 JEEP WRANGLER JK 4 DOOR

PRO-RIDE SYSTEM

2007-2011 JEEP WRANGLER JK 4-DOOR - 4WD

Lift & Method	Qty	Part#	Description	Recommended Accessories	Notes
2" Front/2" Rear	1	024203	Spring Spacer Kit	SHOCKS 98224921 FOX 2.0 Front Gas Shock - 3" kit (2 req'd) 98224931 FOX 2.0 Rear Gas Shock - 3" kit (2 req'd)	4 5
	2	55710	Front 5500 Shock		
	2	55951	Rear 5500 Shock		
Kit #463H 43JK423					
2" Front/2" Rear	1	034202	Front Coil Springs	STABILIZERS 55421 Single 5500 Steering Stabilizer <i>or</i> 95421 Single 9500 Steering Stabilizer	5
	1	034209	Rear Coil Springs		
	1	124320	Front Sway Bar Links		
	2	55700	Front 5500 Shock		
Kit #1402H 68JK815					
3" Front/3" Rear	1	034311	Front Coil Springs	TRACK BARS 124403 Front Adjustable Track Bar 124308 Rear Track Bar Bracket <i>or</i> 124408 Rear Adjustable Track Bar	1
	1	034319	Rear Coil Springs		
1	014312	Complete Box Kit			
Std Kit #1411H 94JK707					
Rubicon Kit #1412H 58JK216	1	124310	Front Sway Bar Disconnects <i>or</i> 124320 Front Sway Bar Links (Rubicon)	ACCESSORIES Page 135 Control Arms 124310 Ultimate Swaybar Disconnects - 2" kit 2034 JKS Quicker Disconnect 124330 Octo Cam Alignment Kit	
	2	55700	Front 5500 Shock		
2	55951	Rear 5500 Shock			
4.5" Front/4" Rear	1	034411	Front Coil Springs	SHOCKS 98224921 FOX 2.0 Front Gas Shock - 4.5" SA kit (2 req'd) 98224922 FOX 2.0 Front Gas Shock - 4.5" LA kit (2 req'd) 98224959 FOX 2.0 Rear Gas Shock - 4.5" kit (2 req'd) 98224952 FOX 2.0 Front Gas Shock - 6.5" kit (2 req'd) 98224958 FOX 2.0 Rear Gas Shock - 6.5" kit (2 req'd)	1 2 7
	1	034419	Rear Coil Springs		
	1	014446	Complete Box Kit		
	1	124310	Front Sway Bar Disconnects <i>or</i> 124320 Front Sway Bar Links (Rubicon)		
	1	124331	Front Lower Fixed Control Arms		
	1	124339	Rear Lower Fixed Control Arms		
	2	55700	Front 5500 Shock		
2	55959	Rear 5500 Shock			
Std Kit #1413H 06JK1341					
Rubicon Kit #1414H 69JK6331					
4.5" Front/4" Rear	1	014691	Front Arm Box Kit	STABILIZERS 55401 Single 5500 Steering Stabilizer <i>or</i> 95421 Single 9500 Steering Stabilizer 55366 Dual Steering Stabilizer Mount Kit 55405 Dual 5500 Steering Stabilizer (2 req'd) <i>or</i> 95405 Dual 5500 Steering Stabilizer (2 req'd)	1 3 7
	1	014689	Rear Arm Box Kit		
	1	014493	Main Box Kit		
	1	034411	Front Coil Springs		
	1	034419	Rear Coil Springs		
	1	124603	Front Sway Bar Disconnects <i>or</i> 124321 Front Sway Bar Links		
	2	55922	Front 5500 Shock		
2	55959	Rear 5500 Shock			
Std Kit #1407H 00JK7872					
Rubicon Kit #1408H 58JK4072					
6.5" Front/6" Rear	1	014691	Front Arm Box Kit	TRACK BARS 124403 Front Adjustable Track Bar 124408 Rear Track Bar Bracket	1 6 7
	1	014689	Rear Arm Box Kit		
	1	014690	Main Box Kit		
	1	124603	Front Sway Bar Disconnects <i>or</i> 124321 Front Sway Bar Links		
	1	034611	Front Coil Springs		
	1	034619	Rear Coil Springs		
	2	55952	Front 5500 Shock		
2	55958	Rear 5500 Shock			
Std Kit #1409H 10JK8482					
Rubicon Kit #1410H 68JK5672					

Notes:

- Will not fit 2wd models.
- The fixed front and rear lower control arms can be upgraded to the flex or adjustable arms listed in the accessories.
- The front driveshaft is maxed out at full droop and on certain models the driveshaft boot can contact the transmission pan. Replacement of the front driveshaft is recommended.
- Removing the OE spring isolators will result in a 1" lift if desired.
- 124408 rear track bar or 124308 rear track bar relocation is recommended if using factory wheels.
- The front and rear driveshafts are maxed out at full droop. The front driveshaft boot can contact the transmission pan at extreme articulation on some models. Replacement of the front and rear driveshafts is recommended.
- Exhaust modification may be required.



#469H - 6.5" Long Arm Lift Kit



2007-2011 JEEP WRANGLER JK 2 DOOR

PRO-RIDE SYSTEM

CHEVROLET/
GMC

DODGE

FORD

JEEP

SUZUKI

TOYOTA

POSI-LOK

SHOCKS/
STEERING
STABILIZERS

APPAREL/
PROMOTIONAL

PRODUCT
SPECS

VEHICLE
SPECS



#1425H - 4" Lift Kit Shown with Optional Adjustable Lower Control Arms

2007-2011 JEEP WRANGLER JK 2-DOOR - 4WD

Lift & Method	Qty	Part#	Description	Recommended Accessories	Notes
2" Front/2" Rear Front Coil Spacers Rear Coil Spacers Kit #463H 43JK423	1 2 2	024203 55710 55951	Spring Spacer Kit Front 5500 Shock Rear 5500 Shock	SHOCKS 98224921 FOX 2.0 Front Gas Shock - 3" kit (2 req'd) 98224931 FOX 2.0 Rear Gas Shock - 3" kit (2 req'd)	4 5
2" Front/2" Rear Front Coil Spacers Rear Coil Spacers Kit #1401H 67JK663	1 1 2 2	024203 124320 55700 55951	Spring Spacer Kit Front Sway Bar Links Front 5500 Shock Rear 5500 Shock	STABILIZERS 55421 Single 5500 Steering Stabilizer <i>or</i> 95421 Single 9500 Steering Stabilizer	4 5
3" Front/3" Rear Front Coil Springs Rear Coil Springs Rear Coil Springs Std Kit #1423H 94JK607 Rubicon Kit #1424H 58JK116	1 1 1 1 1 2 2	034312 034209 014312 124310 124320 55700 55951	Front Coil Springs Rear Coil Springs Complete Box Kit Front Sway Bar Disconnects <i>or</i> Front Sway Bar Links (Rubicon) Front 5500 Shock Rear 5500 Shock	TRACK BARS 124403 Front Adjustable Track Bar 124308 Rear Track Bar Bracket <i>or</i> 124408 Rear Adjustable Track Bar	1
4" Front/4" Rear Front Coil Springs Rear Coil Springs Rear Coil Springs Std Kit #1425H 06JK1341 Rubicon Kit #1426H 69JK6331	1 1 1 1 1 1 2 2	034311 034319 014446 124310 124320 124331 124339 55700 55959	Front Coil Springs Rear Coil Springs Complete Box Kit Front Sway Bar Disconnects <i>or</i> Front Sway Bar Links (Rubicon) Front Lower Fixed Control Arms Rear Lower Fixed Control Arms Front 5500 Shock Rear 5500 Shock	SHOCKS 98224921 FOX 2.0 Front Gas Shock - 4.5" SA kit (2 req'd) 98224922 FOX 2.0 Front Gas Shock - 4.5" LA kit (2 req'd) 98224959 FOX 2.0 Rear Gas Shock - 4.5" kit (2 req'd) 98224952 FOX 2.0 Front Gas Shock - 6.5" kit (2 req'd) 98224958 FOX 2.0 Rear Gas Shock - 6.5" kit (2 req'd)	1 2 7
4" Front/4" Rear Front Long Arm 4-Link Rear Long Arm 4-Link Std Kit #1419H 00JK7872 Rubicon Kit #1420H 58JK4072	1 1 1 1 1 1 2 2	014691 014689 014493 034311 034319 124603 124321 55922 55959	Front Arm Box Kit Rear Arm Box Kit Main Box Kit Front Coil Springs Rear Coil Springs Front Sway Bar Disconnects <i>or</i> Front Sway Bar Links (Rubicon) Front 5500 Shock Rear 5500 Shock	STABILIZERS 55401 Single 5500 Steering Stabilizer <i>or</i> 95421 Single 9500 Steering Stabilizer 55366 Dual Steering Stabilizer Mount Kit 55405 Dual 5500 Steering Stabilizer (2 req'd) <i>or</i> 95405 Dual 5500 Steering Stabilizer (2 req'd)	1 3 7
5.5" Front/5" Rear Front Long Arm 4-Link Rear Long Arm 4-Link Std Kit #1421H 12JK7082 Rubicon Kit #1422H 60JK5272	1 1 1 1 1 1 2 2	014691 014689 014690 124603 124321 034411 034419 55922 55958	Front Arm Box Kit Rear Arm Box Kit Main Box Kit Front Sway Bar Disconnects <i>or</i> Front Sway Bar Links (Rubicon) Front Coil Springs Rear Coil Springs Front 5500 Shock Rear 5500 Shock	TRACK BARS 124403 Front Adjustable Track Bar 124408 Rear Track Bar Bracket	1 6 7
				ACCESSORIES Page 135 4" Adjustable Control Arms 2034 JKS Quicker Disconnect	

Notes:

- Will not fit 2wd models.
- The fixed front and rear lower control arms can be upgraded to the flex or adjustable arms listed in the accessories.
- The front driveshaft is maxed out at full droop and on certain models the driveshaft boot can contact the transmission pan. Replacement of the front driveshaft is recommended.
- Removing the OE spring isolators will result in a 1" lift if desired.
- 124408 rear track bar or 124308 rear track bar relocation is recommended if using factory wheels.
- The front and rear driveshafts are maxed out at full droop. The front driveshaft boot can contact the transmission pan at extreme articulation on some models. Replacement of the front and rear driveshafts is recommended.
- Exhaust modification may be required.

CONTROL ARMS

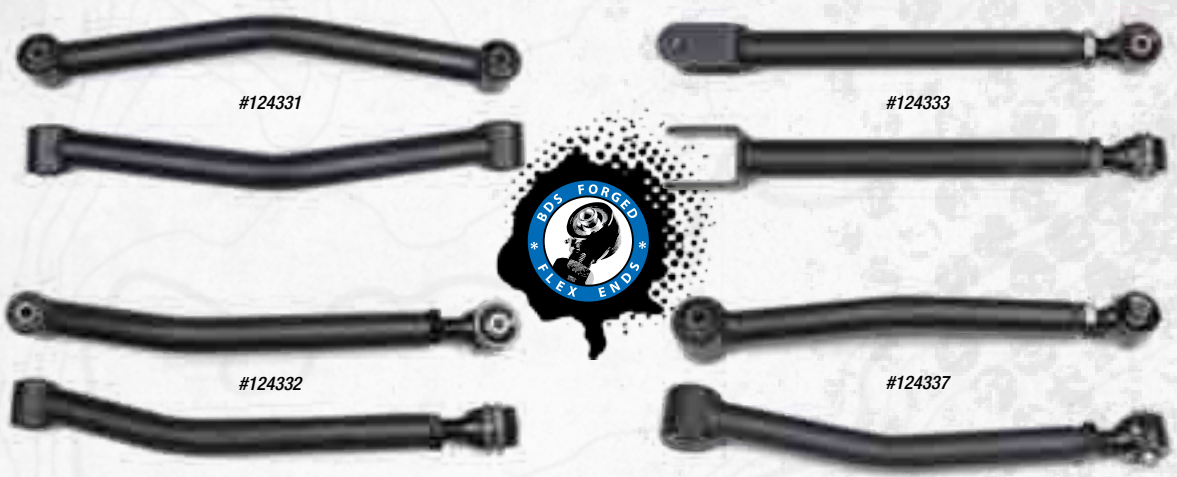

Front Lower Control Arms

- Fixed Length - Rubber Bushings
#124331.....07JK191
- Fixed Length - Poly Bushings
#124361.....07JK191
- Adjustable w/ Forged Flex Ends
Rubber Bushings
#124332.....32JK903
- Adjustable w/ Forged Flex Ends
Poly Bushings
#124362.....32JK903

Rear Lower Control Arms

- Fixed Length - Rubber Bushings
#124339.....07JK191
- Fixed Length - Poly Bushings
#124369.....07JK191
- Adjustable w/ Forged Flex Ends
Rubber Bushings
#124338.....32JK903
- Adjustable w/ Forged Flex Ends
Poly Bushings
#124368.....32JK903

Rear Upper Control Arms

- Adjustable w/ Forged Flex Ends
Rubber Bushings
#124337.....03JK872
- Adjustable w/ Forged Flex Ends
Poly Bushings
#124367.....03JK872

Front Upper Control Arms

- Adjustable w/ Forged Flex Ends
#124333.....50JK732



#174001

Front Bump Stop Extensions

- Extended Length Bump Stops
Black urethane bump stops - pair
#174001.....34JK82



Leveling Spacer

- Includes two front 2" urethane
spacers. *Remove factory isolator
to get 1" lift
#174102.....33JK85
- Includes two rear 2" urethane
spacers.
#174109.....79JK28

Exhaust Extension Kit

- Provides extra front driveshaft
clearance for lifted 2012-2014
JK models.
#124314.....56JK15



Brake Lines

- Stainless Steel Brake Lines
w/ Kevlar lining
For 4.5"-6.5" of Lift.
- Front (pr)
#104002.....72JK931
- Rear (pr)
#104006.....18JK831

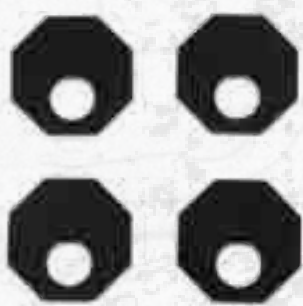

Octo Cam Kit

- #124330.....62JK01



JK Long Arm Upgrade Kit - 2007-2014

This complete upgrade kit will work with most lifted suspension systems ranging from 4.5" to 8.5". The upgrade kit uses 1/4" thick laser-cut frame brackets as well as the long upper and lower arms with forged flex ends and Clevite rubber bushings.

Kit #984H.....38JK0671

Qty	Part#	Description
1	124635	Long Arm Mounting System
1	014691	Front Long Arms
1	014689	Rear Long Arms



#124403

TRACK BAR COMPONENTS



Front Track Bar Relocation Bracket Kit

For 4"-6" of Lift

#124452.....31JK75

Rear Track Bar Relocation Bracket Kit

For 2-3" of Lift

#124308.....86JK26

Rear Track Bar Relocation Bracket Kit

For 4"-6" of Lift

#124457.....73JK34

Front Adjustable Track Bar - Urethane Mount

Heavy duty adjustable track bar to allow for properly centering the axle. For 0-6.5" of Lift *

#124403.....78JK631

Rear Adjustable Track Bar - Urethane Mount

Heavy duty adjustable track bar to allow for properly centering the axle. For 2-6.5" of Lift

#124408.....18JK251

*Note: Must be used with a relocation mount if a dropped pitman arm is used



JK Rear Bar Pin Eliminator

Converts to eyelet bushing style shocks and eases install and removal

#124025.....51JK05



#124310

JK Sway Bar Links

Ultimate Sway Bar Disconnect

For 2"-4.5" of Lift

#124310.....60JK731

Ultimate Sway Bar Disconnect

For 5.5"-6.5" of Lift

#124603.....06JK521



#124408

1997-2006 JEEP WRANGLER TJ

PRO-RIDE SYSTEM

DODGE

#024100 - .75" Spring Spacers



FORD

JEEP

SUZUKI

TOYOTA

POSI-LOK

SHOCKS/
STEERING
STABILIZERS

APPAREL/
PROMOTIONAL

PRODUCT
SPECS

VEHICLE
SPECS

1997-2006 JEEP WRANGLER TJ					
Lift & Method	Qty	Part#	Description	Recommended Accessories	Notes
.75" Front/.75" Rear	1	024100	Spring Spacer Kit	98224979	
	2	55960	Front 5500 Shock	98224972	
	2	55969	Rear 5500 Shock	55407	
Kit #415H				95407	
60JK842				55356	
1.75" Front/1.75" Rear	1	024200	Spring Spacer Kit	55408	
	2	55979	Front 5500 Shock	95408	
	2	55975	Rear 5500 Shock	124311	
Kit #416H				124451	
24JK823				2000	
2" Front/2" Rear	1	034204	Front Coil Springs	124043	
	1	034206	Rear Coil Springs	Page 135	
	2	55979	Front 5500 Shock		
Kit #417H	2	55975	Rear 5500 Shock		
04JK004					
3" Front/3" Rear	1	014320	Complete Box Kit (97-02) or	55407	1
	1	014321	Complete Box Kit (03-06)	95407	
	1	124652	Front Sway Bar Disconnect Kit	55356	
Standard Box Kit	1	124652	Front Sway Bar Disconnect Kit	55408	2
Front Coil Springs	1	034302	Front Coil Springs	95408	
Rear Coil Springs	1	034308	Rear Coil Springs	98224965	
'97-'02 Kit #418H	1	034308	Rear Coil Springs	98224980	
'03-'06 Kit #419H	2	55965	Front 5500 Shock	2001	
41JK017	2	55980	Rear 5500 Shock	124045	
3" Front/3" Rear	1	014314	Complete Box Kit (97-02) or	Page 135	1
	1	014315	Complete Box Kit (03-06)		
	1	124652	Front Sway Bar Disconnect Kit		
Ultimate Kit	1	034302	Front Coil Springs		
Front/Rear Coil Springs	1	034308	Rear Coil Springs		
Adjustable UCA and LCA	1	034308	Rear Coil Springs		
'97-'02 Kit #420H	1	034308	Rear Coil Springs		
'03-'06 Kit #421H	2	55965	Front 5500 Shock		
89JK7391	2	55980	Rear 5500 Shock		



Continued ▶

See Notes ▶



#418H - 3" Kit

3" Kit Features

- Complete box kit includes: 3" Pro-Ride coil springs, front sway bar, Ultimate disconnects, rear sway bar links, rear track bar relocation, bump stop drops, shocks

3" Ultimate Kit Features

- 8 Adjustable upper and lower, heavy duty control arms
- Front and rear D.O.T. approved, Kevlar lined, stainless steel brake lines
- Bump stop extensions and your choice of BDS-5500 or FOX 2.0 Shocks
- Front adjustable track bar and rear track bar relocation bracket
- Front disconnect sway bar links and rear extended links



Vehicle Specs:
3" Lift Kit
33" BFG A/T
15" Street Locks

1997-2006 JEEP WRANGLER TJ

Lift & Method	Qty	Part#	Description	Recommended Accessories	Notes
4.5" Front/4.5" Rear Standard Short Arm Kit Front/Rear Coils Fixed Arms Kit #422H 40JK7161	1	014440	Complete Box Kit	55407 Single 5500 Steering Stabilizer <i>or</i>	3 5
	1	124451	Front Sway Bar Disconnect Kit	95407 Single 9500 Steering Stabilizer	
	1	034451	Front Coil Springs	55356 Dual Stabilizer Kit	
	1	034459	Rear Coil Springs	55408 Dual 5500 Steering Stabilizer (2 req'd) <i>or</i>	
	2	55967	Front 5500 Shock	95408 Dual 9500 Steering Stabilizer (2 req'd)	
4.5" Front/4.5" Rear Ultimate Short Arm Kit Front/Rear Coils Adjustable Arms Kit #423H 85JK7412	1	014460	Complete Box Kit	98224967 FOX 2.0 Front Gas Shock (2 req'd)	3 5
	1	124451	Front Sway Bar Disconnect Kit	98224976 FOX 2.0 Rear Gas Shock (2 req'd)	
	1	034451	Front Coil Springs	2001 JKS Quicker Front Disconnects	
	1	034459	Rear Coil Springs	124045 Belly Skid Plate	
	2	55976	Rear 5500 Shock		
4.5" Front/4.5" Rear 4-Link Long Arm System Front/Rear Coils Adjustable arms Kit #477H 04JK8852	1	014660	Long Arm Box Kit (1of3)	ACCESSORIES  #124045 - High Clearance Belly Pan	3 4 5 6
	1	014441	Long Arm Box Kit (2of3)		
	1	014447	Long Arm Box Kit (3of3)		
	1	124451	Front Sway Bar Disconnect Kit		
	1	034451	Front Coil Springs		
	1	034459	Rear Coil Springs		
	2	55967	Front 5500 Shock		
6.5" Front/6" Rear 4-Link Long Arm System Front/Rear Coils Adjustable Arms Kit #467H 43JK1572	1	014660	Long Arm Box Kit (1of3)	55407 Single 5500 Steering Stabilizer <i>or</i>	3 4 5 6
	1	014651	Long Arm Box Kit (2of3)	95407 Single 9500 Steering Stabilizer	
	1	014656	Long Arm Box Kit (3of3)	55356 Dual Stabilizer Kit	
	1	124652	Front Sway Bar Disconnect Kit	55408 Dual 5500 Steering Stabilizer (2 req'd) <i>or</i>	
	1	034651	Front Coil Springs	95408 Dual 9500 Steering Stabilizer (2 req'd)	
	1	034659	Rear Coil Springs	98224962 FOX 2.0 Front Gas Shock (2 req'd)	
	2	55962	Front 5500 Shock	98224974 FOX 2.0 Rear Gas Shock (2 req'd)	
6.5" Long Arm Kit Features				2001 JKS Quicker Front Disconnects	
				124045 Belly Skid Plate	

Notes

- Models with manual transmissions may need shifter opening in the floorboard enlarged.
- Stabilizer and front lower control arms are highly recommended.
- A slip yoke eliminator kit and CV style rear drive shaft is required.
- May require exhaust modification.
- Some welding required.
- Long Arm systems also fit short wheel base Rubicon models (not Unlimited models)

4.5" Ultimate Kit Features

- (8) Fully adjustable Gen II control arms with rubber bushings and forged flexed ends
- Front and rear D.O.T. approved, Kevlar lined, stainless steel brake lines
- Bump stop extensions
- Front adjustable track bar
- Rear track bar relocation kit
- Front ultimate sway bar disconnects and rear solid links
- Pitman Arm

6.5" Long Arm Kit Features

- True 4-link long arm design to give you castor control through wheel travel
- All control arms come with pre-installed flex joints for extreme wheel travel
- New adjustable front track bar included and a relocation system to match angles with the supplied dropped pitman arm
- Front ultimate sway bar disconnects and extended rear sway bar links
- Front and rear braided stainless steel, kevlar-lined brake lines

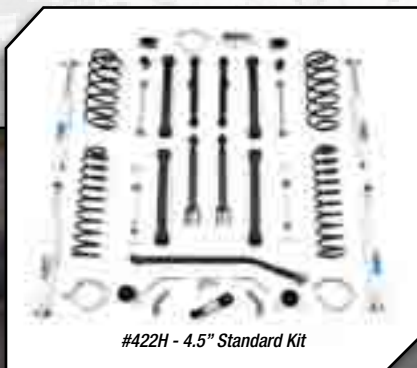
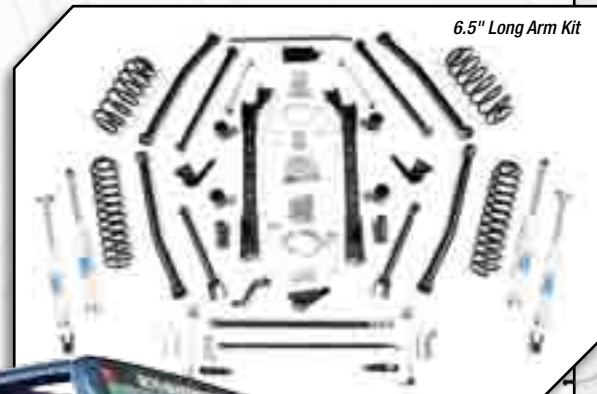

Vehicle Specs:
6.5" Long Arm Kit
35" M/Ts
15" Streetlocks

2003-2006 JEEP WRANGLER TJ UNLIMITED & RUBICON

PRO-RIDE SYSTEM

CHEVROLET/
GMC

DODGE

FORD

JEEP

SUZUKI

TOYOTA

POSI-LOK

SHOCKS/
STEERING
STABILIZERS

APPAREL/
PROMOTIONAL

PRODUCT
SPECS

VEHICLE
SPECS



4.5" Ultimate Kit

4.5" Ultimate Kit Features

- ProRide coils and bump stop extensions
- (8) adjustable upper/lower, front/rear control arms with forged flex ends
- Forged pitman arm to correct steering angle
- Front and rear adjustable track bars to recenter axles
- Front ultimate sway bar disconnects and rear links
- Front and rear braided stainless steel, kevlar-lined brake lines

2003-2006 JEEP WRANGLER TJ UNLIMITED & RUBICON

Lift & Method	Qty	Part#	Description	Recommended Accessories	Notes
.75" Front/.75" Rear Front/Rear Coil Spacers Kit #415H 60JK842	1	024100	Spring Spacer Kit	55407	
	2	55960	Front 5500 Shock	95407	
	2	55969	Rear 5500 Shock	55356	
1.75" Front/1.75" Rear Front/Rear Coil Spacers Kit #416H 24JK823	1	024200	Spring Spacer Kit	55407	
	2	55979	Front 5500 Shock	95407	
	2	55972	Rear 5500 Shock	55356	
				55408	
				95408	
2" Front/2" Rear Front/Rear Coil Springs Kit #417H 04JK004	1	034204	Front Coil Springs	98224979	
	1	034206	Rear Coil Springs	98224972	
	2	55979	Front 5500 Shock	124311	
	2	55972	Rear 5500 Shock	124451	
				2000	
3" Front/3" Rear Standard Kit Front/Rear Coils Kit #424H 75JK866	1	014313	Complete Box Kit	55407	1
	1	124652	Front Sway Bar Disconnect Kit	95407	
	1	034302	Front Coil Springs	55356	
	1	034308	Rear Coil Springs	55408	
	2	55965	Front 5500 Shock	95408	
	2	55980	Rear 5500 Shock	124423	
4.5" Front/4.5" Rear Standard Kit Front/Rear Coils Adj. UCA, Fixed LCA Kit #422H 40JK7161	1	014440	Complete Box Kit	55407	2
	1	124451	Front Sway Bar Disconnect Kit	95407	
	1	034451	Front Coil Springs	55356	
	1	034459	Rear Coil Springs	55408	
	2	55967	Front 5500 Shock	95408	
	2	55976	Rear 5500 Shock	98224967	
				98224976	
				2001	
				124315	
4.5" Front/4.5" Rear Ultimate Kit Front/Rear Coils Adj. UCA, Adj. LCA Kit #423H 85JK7412	1	014460	Complete Box Kit	55407	2
	1	124451	Front Sway Bar Disconnect Kit	95407	
	1	034451	Front Coil Springs	55356	
	1	034459	Rear Coil Springs	55408	
	2	55967	Front 5500 Shock	95408	
	2	55976	Rear 5500 Shock	98224967	

For Long Arm Short Wheel Base Rubicon Kits - see page 95

Notes

1. Stabilizer and front lower control arms are highly recommended.
2. A slip yoke eliminator kit and CV style rear drive shaft may be required.

CONTROL ARMS

After more than a year of development and testing, BDS Suspension is proud to announce the next generation of Jeep control arms is now available for popular Jeep JK, TJ, XJ, MJ, WJ and ZJ applications.

The new BDS control arms come fully assembled and sold in pairs. They also come standard in new BDS long arm and short arm lift kits, see specific kit applications for more information.



#124446



#124349



#124427

Upper Control Arms

Front Fixed Length with Rubber Bushings

#124441.....96JK421

Front Fixed Length with Polyurethane Bushings

#124442.....00JK531

Front Adjustable with Forged Flex Ends

#124341.....97JK622

Rear Fixed Length with Rubber Bushings

#124445.....13JK541

Rear Fixed Length with Polyurethane Bushings

#124446.....39JK561

Rear Adjustable with Forged Flex Ends and Rubber Bushings

#124349.....27JK752

Rear Adjustable with Forged Flex Ends and Polyurethane Bushings

#124447.....27JK752



#124341

THE BUSHING DEBATE... RUBBER vs. POLY

BDS now offers control arms with the option of interchangeable vulcanized rubber bushings or dual fluted greaseable urethane bushings. The new rubber bushing are durometer specific, OEM quality vulcanized Clevite rubber bushings for improved longevity and reduced noise. The new control arms are offered in fixed and adjustable lengths, with your choice of pre-installed rubber bushings or greaseable polyurethane. Arms are built from 1-3/4" OD x .250 wall tubular steel and formed for optimal performance. Rubber/Poly bushing kits are interchangeable and can be purchased separately.

Lower Control Arms - Front or Rear

Fixed Length with Rubber Bushings

#124327.....95JK451

Fixed Length with Polyurethane Bushings

#124427.....95JK451

Adjustable with Forged Flex Ends and Rubber Bushings

#124340.....32JK903

Adjustable with Forged Flex Ends and Polyurethane Bushings

#124360.....32JK903

TJ Long Arm Upgrade Kit

- Works with 4.5" - 8.5" of lift
- Includes upper and lower long arms w/ flex ends
- Includes all control mounting system for long arm installation

Kit# 983H.....67JK4551

Qty	Part#	Description
1	014660	Lower Control Arms
1	124605	Upper Arms & Mounting System



CHEVROLET/
GMC

DODGE

FORD

JEEP

SUZUKI

TOYOTA

POSI-LOK

SHOCKS/
STEERING
STABILIZERS

APPAREL/
PROMOTIONAL

PRODUCT
SPECS

VEHICLE
SPECS

JEEP WRANGLER TJ

ACCESSORIES



#174101

Leveling Spacers

used to compensate for heavy accessories.

Front or Rear .75" spacers (pr.)

#174101.....21JK73

Front or Rear 1.75" spacers (pr.)

#174201.....73JK34

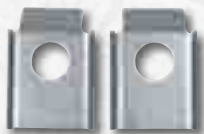

#124014

Protection

TJ Lower Arm Skid Plates

Weld-on lower control arm skid plates made of 3/16" steel to strengthen and protect the front lower arm pockets

#124014.....82JK23

TJ Steering Box Skid Plate

Tight clearance design to maintain ground clearance while adding full protection. For Saginaw box only.

#124051.....78JK35



#174001

Bump Stop Extensions

Extended Length Bump Stops
Black urethane bump stops - pair

#174001.....34JK82



Front

Brake Lines

TJ Stainless Steel Brake Lines
DOT approved, Kevlar lined, 26" heavy-duty brake line. For 3"-6.5" of Lift.

Front

#104001.....89JK011

Rear

#104009.....07JK94



#124051



1997-2006 High Clearance Belly Pan

BDS's "belly up" style skid plate is built for off-road abuse. Constructed from 3/16" steel with corner gussets, this belly pan skid increases ground clearance and is designed to add underbody protection. The kit works on stock height Jeeps as well as in conjunction with most short arm lift kits and BDS long arm kits. Unlike other belly up skids on the market, the BDS Belly Skid Plate includes a low profile transmission mount which allows for additional ground clearance without requiring a motor mount lift. Fits 6 cylinder TJs, except '03-06 automatics. Rubicon models require minor modification. Will not work in conjunction with t-case drop kits or on 4 cylinder models.

#124045.....78JK334



#124323

Sway Bar Links

TJ Front Ultimate Sway Bar Disconnect

On road stability and off-road performance. Easy one handed operation.

For 0"-2" of Lift

#124451.....08JK051

For 3"-4.5" of Lift

#124652.....08JK051

For 6.5" of Lift

#124651.....08JK051

TJ Solid Rear Sway Bar Link For 2"-3" of Lift

#124309.....79JK64

TJ Solid Front Sway Bar Link For 2"-3" of Lift

#124313.....17JK34

Drive Line Adjustment

TJ Transfer Case Lowering Kit

97-02 - 1.5"

#124323.....53JK07

03-06 - 1.5"

#124324.....53JK07

03-06 - .75"

#124315.....59JK74

TJ Front Alignment Cam Bolt

Easily adjust caster with front cam bolts

#124311.....78JK63

Rear Pinion Cam Bolts

Allows for precision adjustment of the rear pinion angle

#124319.....15JK53



#124303

Track Bar Components

TJ Rear Track Bar Relocation Kit

For 3" of Lift

#124303.....42JK55

For 4.5" of Lift

#124459.....51JK35

TJ Front Adjustable Track Bar

Heavy-duty adjustable track bar to allow for properly centering the axle. For 2"-4" of Lift

#124423.....48JK271

TJ Front Adjustable Track Bar

Must use with dropped pitman arm. For 4.5"-6.5" of Lift

#124602.....56JK371

TJ Adjustable Track Bar

Must be used with dropped pitman arm. This is the same system as used in the BDS 6.5" longarm.

#124601.....09JK802

TJ Rear Adjustable Track Bar

Heavy-duty adjustable track bar to allow for properly centering the axle. Tech Note: 3" and up use w/124303.

#124429.....73JK771



#124009

Shock Relocation Kit

TJ Rear Lower Shock Relocation Kit

#124009.....44JK07

Shock Conversion

TJ Shock Stem Eliminator

Allows use of eye-to-eye shock in stem-eye location

#124015.....13JK82

Bar Pin Eliminator - Rear

#124022.....47JK63



#124015

2", 3.5" & 4.5" Kit Features

- Glide-Ride leaf springs come complete with anti-friction pads, bolt-style leaf alignment clamps, full military wrap and roll pointed leaves
- Complete 3.5" kit includes: front anti-sway bar links, front and rear track bar relocation brackets, bump stop contact brackets, u-bolts, urethane bushings, transfer case drop kit, rear pinion shims and front and rear brake line relocation brackets and drop pitman arm (PS)
- The 4.5" Ultimate Kit includes: front ultimate anti-sway bar dual disconnects, front and rear track bar relocation brackets, u-bolts, complete set of spring and shackle bushings, transfer case drop kit, rear pinion shims, pitman arm, front and rear 1" shackles, all new spring eye and shackle bolts, front and rear Kevlar lined, and stainless steel brake lines.



3.5" Kit



4.5" Kit

1987-1995 JEEP WRANGLER YJ

Lift & Method	Qty	Part#	Description	Recommended Accessories	Notes
2" Front/2" Rear Front Leaf Springs Rear Leaf Springs Kit #408H 00JK937	4	004200	Leaf Spring	55407	Single 5500 Steering Stabilizer <i>or</i> Single 9500 Steering Stabilizer 3 Dual Steering Stabilizer Kit Dual 5500 Steering Stabilizer (2 req'd) 124001 4100 124102 074004 PSL900 Front Sway Bar Link Kit JKS Quicker Disconnects Front or Rear Shackles 1" Lift (pair) Frame Shackle Bushing Kit (All) 4x4 Posi-Lok™ (page 119)
	1	014200	Complete Box Kit	95407	
	2	55945	Front 5500 Shock	55353	
	2	55900	Rear 5500 Shock	55402	
				124001	
				4100	
3.5" Front/3.5" Rear Soft Top Applications Front Leaf Springs Rear Leaf Springs Kit #409H 98JK289	2	004351	Front Leaf Spring	55407	Single 5500 Steering Stabilizer <i>or</i> Single 9500 Steering Stabilizer 1 2 3 4 5 Dual Stabilizer Kit Dual 5500 Steering Stabilizer (2 req'd) 124102 074004 Front or Rear Shackles 1" Lift (pair) Frame Shackle Bushing Kit (All) 124352 4100 PSL920 Front Sway Bar Disconnects <i>or</i> JKS Quicker Disconnects 4x4 Posi-Lok™ (page 119)
	2	004359	Rear Leaf Spring	95407	
	1	014351	Complete Box Kit	55353	
	1	124001	Front Sway Bar Links	55402	
	1	084404	Pitman Arm (PS)	124102	
	2	55955	Front 5500 Shock	074004	
3.5" Front/3.5" Rear Hard Top Applications Front Leaf Springs Rear Leaf Springs Kit #410H 92JK589	4	004351	Leaf Spring	124352	Front Sway Bar Disconnects <i>or</i> JKS Quicker Disconnects 4x4 Posi-Lok™ (page 119)
	1	014351	Complete Box Kit	4100	
	1	124001	Front Swaybar Links	PSL920	
	1	084404	Pitman Arm (PS)		
	2	55955	Front 5500 Shock		
	2	55950	Rear 5500 Shock		
4.5" Front/4.5" Rear Soft Top Applications Front Leaf Springs Rear Leaf Springs Kit #411H 36JK0831	2	004351	Front Leaf Spring	55407	Single 5500 Steering Stabilizer <i>or</i> Single 9500 Steering Stabilizer 1 2 4 5 7 8 Dual Steering Stabilizer Kit Dual 5500 Steering Stabilizer (2 req'd) 4100 JKS Quicker Disconnects 074004 Frame Shackle Bushing Kit (All) PSL920 4x4 Posi-Lok™ (page 119)
	2	004359	Rear Leaf Spring	95407	
	1	014461	Complete Box Kit	55353	
	1	124503	Front Sway Bar Disconnect Kit	55402	
	2	55955	Front 5500 Shock	4100	
	2	55950	Rear 5500 Shock	074004	
4.5" Front/4.5" Rear Hard Top Applications Front Leaf Springs Rear Leaf Springs Kit #412H 30JK3831	4	004351	Front Leaf Spring	124352	Front Sway Bar Disconnects <i>or</i> JKS Quicker Disconnects 4x4 Posi-Lok™ (page 119)
	1	014461	Complete Box Kit	4100	
	1	124503	Front Sway Bar Disconnect Kit	PSL920	
	2	55955	Front 5500 Shock		
	2	55950	Rear 5500 Shock		
	2	55950	Rear 5500 Shock		

See Notes ▶

Continued ▶



Vehicle Specs:
3.5" Lift Kit
33" BFG M/T
15" AR Baja

JEEP WRANGLER YJ

GLIDE-RIDE SYSTEM



6" Ultimate Kit

Vehicle Specs:
4.5" Lift Kit
35" M/T MTZ
15" M/T Sidebiter



Photo credit: Jamie Dee Wilson

1987-1995 JEEP WRANGLER YJ

Lift & Method	Qty	Part#	Description	Recommended Accessories	Notes	
5" Front/5" Rear	4	004500	Front Leaf Spring	55407	Single 5500 Steering Stabilizer or	2
Front Leaf Springs	1	014501	Complete Box Kit	95407	Single 9500 Steering Stabilizer	3
Rear Leaf Springs	1	124013	Front Sway Bar Links	55353	Dual Steering Stabilizer Kit	6
Kit #1431H	2	55660	Front 5500 Shock	55402	Dual 5500 Steering Stabilizer (2 req'd)	8
27JK3221	2	55920	Rear 5500 Shock	4100	JKS Quicker Disconnects	
				124102	Front or Rear Shackles 1" Lift (pr)	
				98224660	FOX 2.0 Front Gas Shock (2 req'd)	
				98224920	FOX 2.0 Rear Gas Shock (2 req'd)	
				PSL920	4x4 Posi-Lok™ (page 119)	
6" Front/6" Rear	4	004500	Front Leaf Spring	55407	Single 5500 Steering Stabilizer or	2
Front Leaf Springs	1	014501	Complete Box Kit	95407	Single 9500 Steering Stabilizer	6
Rear Leaf Springs	1	124503	Front Sway Bar Disconnect Kit	55353	Dual Steering Stabilizer Kit	8
Kit #1432H	2	124102	Front 1" Extended Shackles	55402	Dual 5500 Steering Stabilizer (2 req'd)	
29JK7051	2	55660	Front 5500 Shock	4100	JKS Quicker Disconnects	
	2	55920	Rear 5500 Shock	98224660	FOX 2.0 Front Gas Shock (2 req'd)	
				98224920	FOX 2.0 Rear Gas Shock (2 req'd)	
				PSL920	4x4 Posi-Lok™ (page 119)	

Notes

1. May require driveshaft lengthening for 13" (u-joint to u-joint) driveshaft.
2. May require larger diameter driveshaft if equipped with a 41-1/2" front driveshaft.
3. Extended shackles recommended to clear military wrap.
4. Models with accessories like hardtop, rear tire carrier, roof rack etc., should use #004351 springs on front and rear.
5. When combining lifted shackles with a 3.5" suspension system, a tail shaft eliminator kit and a "CV" style rear driveshaft may be required to eliminate driveline vibration.
6. A tail shaft eliminator and CV style rear drive shaft is required and it may be necessary to lengthen the front driveshaft.
7. #124015 front stem eliminator required to use FOX shocks.
8. Includes pitman arm for power steering equipped models only.

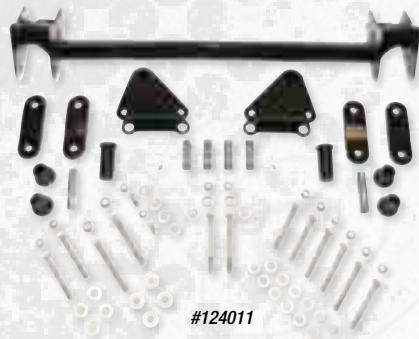

#124011

YJ Shackle Reversal Kit

Better handling, less bump steer, no welding required, produces less than 1" of lift

#124011.....47JK523



#124102

Shackles

Bolt together style shackles made from 3/8" steel 1" lift front or rear YJ Shackles (pair)

#124102.....55JK08



#104001

Brake Lines

YJ Stainless Steel Brake Lines

DOT approved, Kevlar lined. For 4.5"-6.5" of Lift.

Front

#104001.....89JK011

Rear

#104007.....07JK94

Track Bar Components

YJ Front & Rear Track Bar Relocation Bracket Kit

Contains front and rear track bar relocation brackets and hardware for 3.5"-4.5" of lift

#124004.....91JK36

Front Track Bar Relocation Bracket Kit

Includes front track bar relocation bracket and hardware for 5"-6" of lift

#124501.....97JK43

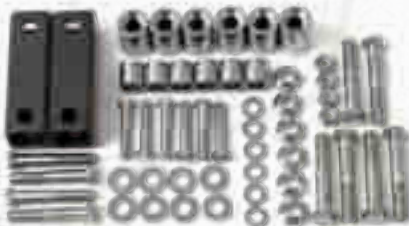

Drive Line Adjustment

YJ Transfer Case Drop

For 3.5"-4.5" of Lift

#124003.....90JK34



#124050

Protection

YJ Steering Box Skid Plate

Made from 3/16" steel with durable black powder coat; snug design to offer as much ground clearance as possible while protecting your steering box

#124050.....90JK34



#124015

Shock Conversion

YJ Shock Stem Eliminator

Allows use of eye-to-eye shock in front stem-eye shock location

#124015.....13JK82

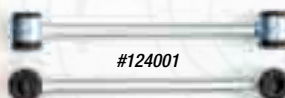

#124001

Sway Bar Links

YJ Front Ultimate Sway Bar Disconnect

On road stability and off-road performance. Easy one handed operation.

For 3.5" of Lift

#124352.....51JK161

For 4.5"-6" of Lift

#124503.....51JK161

YJ Solid Front Sway Bar Link

For 2"-3.5" of Lift

#124001.....10JK63

For 5"-6" of Lift

#124013.....50JK83



See Page 119

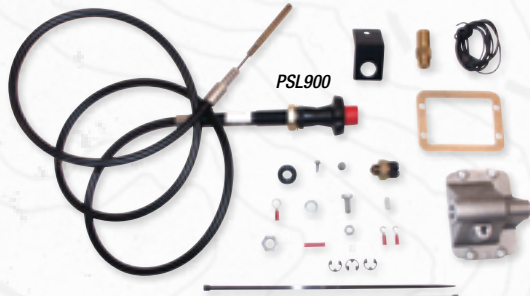

PSL900

#PSL100

#PSL900 (stock applications)
#PSL920 (lifted applications over 3")
#PSL100 Heavy-duty fork with pads

JEEP CJ5, CJ7, SCRAMBLER

GLIDE-RIDE SYSTEM

DODGE

FORD

JEEP

SUZUKI

TOYOTA

POSI-LOK

SHOCKS/
STEERING
STABILIZERS

APPAREL/
PROMOTIONAL

PRODUCT
SPECS

VEHICLE
SPECS

4" Kit Features

- 4" Glide-Ride leaf springs —complete with anti-friction pads, bolt style leaf alignment clamps, full military wrap, and roll pointed leaves
- 4" front box kit includes: u-bolts, hi-nuts, washers, urethane bushings, sleeves and rear pinion shims



4" Glide-Ride Leaf Springs

Vehicle Specs:
2.5" Lift Kit
33" D/C FC-II
15" Steel Wheels



1976-1986 JEEP CJ5, CJ7 & SCRAMBLER

Lift & Method	Qty	Part#	Description	Recommended Accessories	Notes
2.5" Front / 2.5" Rear	2	004251	Front Leaf Spring	98224900 FOX 2.0 Front Gas Shock (2 req'd)	2
Front Leaf Springs	2	004259	Rear Leaf Spring	98224950 FOX 2.0 Rear Gas Shock (2 req'd)	4
Rear Leaf Springs	1	014250	Box Kit	Page 128 Steering Stabilizers	
'82-'86 Kit #405H	2	55900	Front 5500 Shock <i>or</i>	124002 Anti-Sway Bar Extension Kit	
'76-'81 Kit #483H	2	55910	76-81 Front Shock	4100 JKS Quicker Disconnects	
24JK837	2	55950	Rear 5500 Shock	074002 Shackle Bushing Kit (1 Req'd)	
				124000 Transfer Case Drop Kit	
4" Front / 4" Rear	2	004401	Front Leaf Spring	98224920 FOX 2.0 Front Gas Shock - '82-'86 (2 req'd)	1
Front Leaf Springs	2	004409	Rear Leaf Spring	98224920 FOX 2.0 Rear Gas Shock - '82-'86 (2 req'd)	2
Rear Leaf Springs	1	014400	Box Kit	98224900 FOX 2.0 Front Gas Shock - '76-'81 (2 req'd)	3
'82-'86 Kit #406H	1	084401	Pitman Arm (PS)	98224920 FOX 2.0 Rear Gas Shock - '76-'81 (2 req'd)	4
'76-'81 Kit #407H	1	124000	Transfer Case Drop Kit	Page 128 Steering Stabilizers	
48JK848	2	55920	82-86 Front Shock <i>or</i>	124002 Anti-Sway Bar Extension Kit	
	2	55900	76-81 Front Shock	4100 JKS Quicker Disconnects	
	2	55920	Rear 5500 Shock	074002 Shackle Bushing Kit (1 Req'd)	
				114208 H. D. Rear Lift Kit	
				(Add to #004409 spring)	

Notes

1. Extended brake lines recommended.
2. Vehicles equipped with optional Dana 44 Axle will require 4005 U-bolts (Qty. 4).
3. Heavy models with accessories like hard top, tire carrier, roof rack, etc., should order #114208 H.D. Leaf Kit before installation of #004409 rear springs. This kit is highly recommended for all CJ8 Scramblers.
4. #074002 shackle bushing kit is highly recommended.



**2.0 PERFORMANCE
SERIES SHOCKS AVAILABLE**





#124002

Sway Bar Links

For 2.5" to 4" of Lift

#124002.....10JK63



Bushing Kits

8 Polyurethane bushings for
frame-mounted shackles

#074002.....67JK91

Shackles

Bolt together style shackles made
from 3/8" steel

1/2" Front Shackles (pair)

#124101.....22JK76

1/2" Rear Shackles (pair)

#124109.....34JK46

1-3/8" Front Shackles (pair)

#124103.....55JK08

1-3/8" Rear Shackles (pair)

#124119.....55JK08



Vehicle shown with 4" Lift
and YJ Spring Conversion Kit

YJ Spring Conversion Kit

• Install any YJ springs under your '76-'86 CJ

Kit #124021 Includes:

- New heavy-duty greaseable hangers
- New upper shackle mount bushings
- Heavy-duty spring mounting plates with u-bolts
- Note: Leaf spring eye bushings, pitman arm, etc., are not included in this kit. This is strictly the mounting system required to convert to YJ springs
- Note: New shackles are required for installation
1/2" shackles (#124109 qty.2) - 1-3/8" shackles (#124119 qty.2)

#124021.....55JK593



#124021 - Spring Conversion Kit

JEEP CJ5, CJ6, M38A1

GLIDE-RIDE SYSTEM



- Glide-Ride leaf springs—complete with anti-friction pads, bolt style leaf alignment clamps, full military wrap, and roll pointed leaves
- Front/rear box kit includes—u-bolts, hi-nuts, and washers

1972-1975 JEEP CJ5 & CJ6

Lift & Method	Qty	Part#	Description	Recommended Accessories	Notes
2.5" Front / 2.5" Rear	2	004252	Front Leaf Spring	98224900	1
Front Leaf Springs	2	004258	Rear Leaf Spring	98224900	
Rear Leaf Springs	1	014253	Box Kit	Page 128	
Kit #400H	2	55900	Front 5500 Shock	FOX 2.0 Front Gas Shock (2 req'd)	
12JK327	2	55900	Rear 5500 Shock	FOX 2.0 Rear Gas Shock (2 req'd) Steering Stabilizers	

1969-1971 JEEP CJ5, CJ6

Lift & Method	Qty	Part#	Description	Recommended Accessories	Notes
2.5" Front / 2.5" Rear	2	004252	Front Leaf Spring	98224900	1
Front Leaf Springs	2	004258	Rear Leaf Spring	98224900	
Rear Leaf Springs	1	014252	Box Kit	Page 128	
Kit #401H	2	55900	Front 5500 Shock	FOX 2.0 Front Gas Shock (2 req'd)	
12JK327	2	55900	Rear 5500 Shock	FOX 2.0 Rear Gas Shock (2 req'd) Steering Stabilizers	

1953-1968 JEEP CJ5, CJ6, M38A1

Lift & Method	Qty	Part#	Description	Recommended Accessories	Notes
2.5" Front / 2.5" Rear	2	004252	Front Leaf Spring	98224900	1
Front Leaf Springs	2	004258	Rear Leaf Spring	98224900	
Rear Leaf Springs	1	014251	Box Kit	Page 128	
Kit #402H	2	55900	Front 5500 Shock	FOX 2.0 Front Gas Shock (2 req'd)	
12JK327	2	55900	Rear 5500 Shock	FOX 2.0 Rear Gas Shock (2 req'd) Steering Stabilizers	

Notes

1. #004252 and #004258 springs come with OE style bushings installed.

JEEP CHEROKEE & WAGONEER

GLIDE-RIDE SYSTEM



- Glide-Ride leaf springs with anti-friction pads, bolt-style leaf alignment clamps and tapered leaves, to give a smooth ride through full wheel travel
- Box kit includes new front and rear u-bolts and brake line relocation brackets

1974-1990 J10, J20 GRAND WAGONEER, CHEROKEE SJ FULL SIZE 4WD

Lift & Method	Qty	Part#	Description	Recommended Accessories	Notes
4" Front / 3" Rear	2	004402	Front Leaf Spring	Page 128	1, 2 4, 5 6
Front Leaf Springs	1	014401	Front & Rear Box Kit	083402	
3" Rear Blocks	2	55875	Front 5500 Shock	119158	
Kit #403H	2	55920	Rear 5500 Shock	121009	
47JK096				Spring Eye Bolt Kit (1 required per axle)	
4" Front / 4" Rear	2	004402	Front Leaf Spring	Page 128	1, 2 3, 4 5, 6
Front Leaf Springs	2	004408	Rear Leaf Spring	083402	
Rear Leaf Springs	1	014402	Front & Rear Box Kit	121009	
Kit #404H	2	55875	Front 5500 Shock	Steering Stabilizers	
06JK1711	2	55920	Rear 5500 Shock	Pitman Arm (PS) Spring Eye Bolt Kit (1 required per axle)	

Notes

1. #083402 Pitman arm will increase turning radius (cannot turn as sharp).
2. Not recommended for Wagoneers or Cherokees with front and / or rear track rods.
3. 1974-1975 models must have 131" wheelbase and 7200# GVWR or more for #004408 rear springs to fit.
4. Some 1974 J20's with stock 401 come with a rear 15/16" spring eye stud.
5. #004402 and #004408 come with OE rubber bushings installed.
6. Rear shock mount may need to be relocated.

JEEP CHEROKEE XJ 2WD & 4WD PRO-RIDE SYSTEM

CHEVROLET/
GMC

DODGE

FORD

JEEP

SUZUKI

TOYOTA

POSI-LOK

SHOCKS/
STEERING
STABILIZERS

APPAREL/
PROMOTIONAL

PRODUCT
SPECS

VEHICLE
SPECS

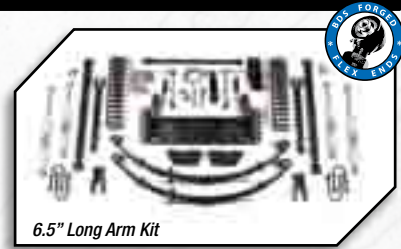
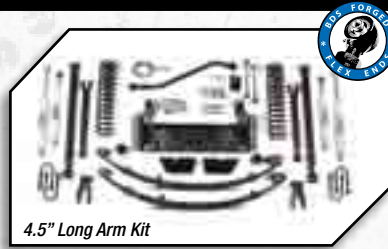
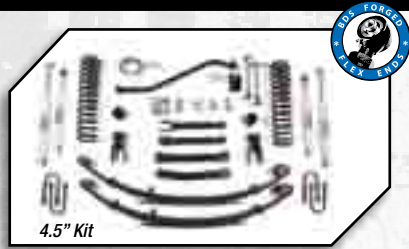

3" System Features

- 3" Pro-Ride coil springs and rear Glide-Ride add-a-leaf or leaf springs
- Transfer case lowering kit corrects driveline vibration
- Front sway bar links included

4.5" System Features

- Box kit includes heavy-duty adjustable upper and lower control arms
- Kevlar lined, DOT approved, stainless steel brake lines are included
- A front adjustable track bar is included to properly center the axle
- Ultimate sway bar disconnects are included to ensure on road stability while allowing for off-road capability
- The rear is lifted via BDS 3" Glide-Ride rear springs and a 1" rear shackle to assist with maximum articulation

4.5" Long Arm System Features

- Heavy-duty, high clearance belly pan for the ultimate in protection and support
- No welding to the uni-body required
- Extended length upper and lower control arms create a true long arm 4-link system
- Stainless steel Kevlar lined brake lines included
- BDS Ultimate Sway Bar Disconnects
- Rear 5" leaf springs with extended length shackles for some serious flex
- Adjustable upper control arms with flex joints
- Adjustable lower arms built to handle off road abuse
- Adjustable track bar for smooth controlled steering

6.5" & 8.5" Long Arm System Features

- Heavy-duty, high clearance belly pan for the ultimate in protection and support
- No welding to the uni-body required
- Extended length upper and lower control arms create a true long arm 4-link system
- Stainless steel Kevlar lined brake lines included
- BDS Ultimate Sway Bar Disconnects
- Rear 5" leaf springs with extended length shackles for some serious flex
- Adjustable upper control arms with flex joints
- Adjustable lower arms built to handle off road abuse
- Extreme dropped pitman arm working with a relocated adjustable track bar for smooth controlled steering



1984-2001 JEEP CHEROKEE XJ 2WD & 4WD

Lift & Method	Qty	Part#	Description	Recommended Accessories	Notes
.75" Front/1" Rear	1	174101	Front Coil Spacers	55401 Single 5500 Steering Stabilizer	
Front Coil Spacers	1	124107	Rear 1" Shackles	PSL900 4x4 Posi-Lok™ (page 119)	
Rear Shackles	2	55979	Front 5500 Shock	124006 Transfer Case Lowering Kit	
Kit #484H	2	55972	Rear 5500 Shock	98224979 FOX 2.0 Front Gas Shock (2 req'd)	
13JK213				98224972 FOX 2.0 Rear Gas Shock (2 req'd)	2
1.75" Front/2" Rear	1	014205	Front Spacer & Rear Add-a-Leaf Chrysler 8.25 or	2002 JKS Quicker Disconnects	
Front Coil Spacers	1	014206	Front Spacer & Rear Add-a-Leaf Dana 35	Page 135 Control Arm Options	
Rear Add-A-Leafs	2	55979	Front 5500 Shock		
8.25 Axle Kit #426H	2	55972	Rear 5500 Shock		
Dana Axle Kit #427H					
04JK513					
2" Front/2" Rear	1	034211	Front Coil Springs		1
Front Coil Springs	1	114202	Add-A-Leaf Kit		2
Rear Add-A-Leafs	4	4012	U-bolt Kit - Chrysler 8.25 or		
8.25 Axle Kit #428H	4	4005	U-bolt Kit - Dana 35		
Dana Axle Kit #429H	2	55979	Front 5500 Shock		
97JK514	2	55972	Rear 5500 Shock		
3" Front/2.5" Rear	1	034301	Front Coil Springs	98224965 FOX 2.0 Front Gas Shock (2 req'd)	1
Front Coil Springs	1	014316	Box Kit - Chrysler 8.25 or	98224980 FOX 2.0 Rear Gas Shock (2 req'd)	2
Rear Add-A-Leaf & Block	1	014317	Box Kit - Dana 35		
8.25 Axle Kit #430H	1	124306	Extended Sway Bar Links	55401 Single 5500 Steering Stabilizer	
Dana Axle Kit #431H	2	55965	Front 5500 Shock	124327 Front Fixed LCA (rubber - pair)	
92JK265	2	55980	Rear 5500 Shock	PSL900 4x4 Posi-Lok™ (page 119)	
3" Front/3" Rear	1	034301	Front Coil Springs	124423 Front Adjustable Track Bar	1
Front Coil Springs	2	004209	Rear Leaf Spring	124451 Ultimate Sway Bar Disconnect Kit or	2
Rear Leaf Springs	1	014302	Box Kit	2000 JKS Quicker Disconnect Kit	8
8.25 Axle Kit #432H	1	124306	Extended Sway Bar Links	Page 135 Control Arm Options	
Dana Axle Kit #433H	4	4012	U-bolt Kit - Chrysler 8.25 or		
32JK989	4	4005	U-bolt Kit - Dana 35		
	2	55965	Front 5500 Shock		
	2	55980	Rear 5500 Shock		

See Notes ►

Continued ►

CHEVROLET/
GMC

DODGE

FORD

JEEP

SUZUKI

TOYOTA

POSI-LOK

SHOCKS/
STEERING
STABILIZERS

APPAREL/
PROMOTIONAL

PRODUCT
SPECS

VEHICLE
SPECS



Vehicle Specs:
8.5" Long Arm Kit
35" M/T MTZ
15x10 M/T Classic Lock



#124656 - Optional Transfer Case Skid Plate. Will only work with NP231. Shown in gray, available in black only

1984-2001 JEEP CHEROKEE XJ 2WD & 4WD (CONTINUED)

Lift & Method	Qty	Part#	Description	Recommended Accessories	Notes
4.5" Front/4" Rear Front Coil Springs Rear Leaf Springs 8.25 Axle Kit #434H Dana Axle Kit #435H 24JK7961	1	034452	Front Coil Springs	98224965	FOX 2.0 Front Gas Shock (2 req'd) FOX 2.0 Rear Gas Shock (2 req'd) 55401 Single 5500 Steering Stabilizer PSL920 4x4 Posi-Lok™ (page 119) 2001 JKS Quicker Disconnect
	2	004209	Rear Leaf Spring	98224974	
	1	014444	Box Kit	55401	
	1	124451	Front Sway Bar Disconnect Kit	PSL920	
	4	4012	U-bolt Kit - Chrysler 8.25 or	2001	
	4	4005	U-bolt Kit - Dana 35		
	2	55965	Front 5500 Shock		
	2	55974	Rear 5500 Shock		

1987-2001 JEEP CHEROKEE XJ 4WD - LONG ARM SYSTEMS JEEP SPEED APPROVED!

Lift & Method	Qty	Part#	Description	Recommended Accessories	Notes
4.5" Front/4" Rear Front Long Arm Rear Leaf Springs 8.25 Axle Kit #1427H Dana Axle Kit #1428H 79JK3632	1	034452	Front Coil Springs	SHOCKS 98224965 FOX 2.0 Front Gas Shock - 4.5"- 6.5" kit (2 req'd) 98224974 FOX 2.0 Rear Gas Shock - 4.5" kit (2 req'd) 98224962 FOX 2.0 Front Gas Shock - 8.5" kit (2 req'd) 98224961 FOX 2.0 Rear Gas Shock - 4.5"- 6.5" kit (2 req'd) STABILIZERS 55401 Single 5500 Steering Stabilizer PROTECTION 124656 Transfer Case Skid Plate 124014 LCA Skid Plates 2001 JKS Quicker Disconnect	1 3
	1	014445	Main Box Kit		
	1	014654	Belly Pan Box Kit		
	1	014655	Long Flex Arms		
	1	124451	Front Sway Bar Disconnect Kit		
	2	004209	Rear Leaf Spring		
	4	4012	U-bolt Chrysler 8.25 or		
	4	4005	U-bolt Kit - Dana 35		
	2	55965	Front 5500 Shock		
	2	55974	Rear 5500 Shock		
6.5" Front/6" Rear Front Long Arm Rear Leaf Springs Kit #1433H* 67JK8552	1	034652	Front Coil Springs	124656 Transfer Case Skid Plate 124014 LCA Skid Plates 2001 JKS Quicker Disconnect	3 4 5 6 7
	1	014641	Main Box Kit		
	1	014654	Belly Pan Box Kit		
	1	014655	Long Flex Arms		
	1	124451	Front Sway Bar Disconnect Kit		
	2	004509	Rear Leaf Spring		
	1	174001	87-96 Front Bump Stops or		
	1	174002	97-01 Front Bump Stops		
	1	014658	Rear Box Kit- Dana 35 or		
	1	014659	Rear Box Kit - Chrysler 8.25		
8.5" Front/8" Rear Front Long Arm Rear Leaf Springs Kit #1434H* 87JK4762	1	034852	Front Coil Springs	124656 Transfer Case Skid Plate 124014 LCA Skid Plates 2001 JKS Quicker Disconnect	1 3 4 5 6 7
	1	014841	Main Box Kit		
	1	014654	Belly Pan Box Kit		
	1	014655	Long Flex Arms		
	1	124652	Front Sway Bar Disconnect Kit		
	2	004509	Rear Leaf Spring		
	1	174001	87-96 Front Bump Stops or		
	1	174002	97-01 Front Bump Stops		
	1	014858	Rear Box Kit- Dana 35 or		
	1	014859	Rear Box Kit - Chrysler 8.25		



#124014 - LCA Skid Plates

* Base kit # includes options for 97-01 model with Chrysler 8.25 rear axle.

- Notes
1. Measure the rear u-bolts before ordering. Some XJ's are equipped with a Dana 44 rear axle.
 2. Transfer case lowering kit is not required for 2WD models.
 3. CV style rear driveshaft (not included) and slip yoke eliminator kit is required.
 4. System only works with 4.0L motor and automatic transmission.
 5. Some welding required.
 6. '96 and earlier models may require a longer emergency brake cable.
 7. 124656 will only work with NP231
 8. Will produce tail-high stance by 1.5".



XJ Long Arm Upgrade Kit

- Works with 4.5" - 8.5" of lift
- Fully welded 3-piece subframe belly pan assembly
- Upper and lower adjustable control arms with forged flex ends and Clevis rubber bushings
- Works on 87-01 models with 4.0L motor and automatic transmission only

#981H.....97JK949

Qty	Part#	Description
1	014655	Control Arm Box Kit
1	014654	Belly Pan Box Kit



Track Bars

XJ Front Adjustable Track Bar

Heavy-duty adjustable track bar to allow for properly centering the axle.

For 2"-4.5" of Lift

#124423.....48JK271

XJ Front Adjustable Track Bar

Must use with dropped pitman arm.

For 4.5"-6.5" of Lift

#124602.....56JK371

XJ Front Adjustable Track Bar

Must use with dropped pitman arm. Includes replacement frame mount bracket.

For 6.5"-9" of Lift

#124611.....17JK632



Front Upper Control Arms

Fixed Length with Rubber Bushings

#124441.....96JK421

Fixed Length with Polyurethane Bushings

#124442.....00JK531

Adjustable with Forged Flex Ends

#124341.....97JK622



Shackles

XJ Rear Shackles

Heavy-duty greaseable 1" shackles

#124107.....93JK59



Shock Conversion

TJ Shock Stem Eliminator

Allows use of eye-to-eye shock in stem-eye location

#124015.....13JK82

Bar Pin Eliminator - Rear

#124022.....47JK63



Sway Bar Links

XJ Front Ultimate Sway Bar Disconnect

On road stability and off-road performance. Easy one handed operation.

For 3"-4.5" of Lift

#124451.....08JK051

For 6.5" of Lift

#124652.....08JK051

XJ Solid Front Sway Bar Link

For 2"-3" of Lift

#124306.....53JK18

Front Lower Control Arms

Fixed Length with Rubber Bushings

#124327.....95JK451

Fixed Length with Polyurethane Bushings

#124427.....95JK451

Adjustable with Forged Flex Ends and Rubber Bushings

#124340.....32JK903

Adjustable with Forged Flex Ends and Polyurethane Bushings

#124360.....32JK903

Drive Line Adjustment

XJ Transfer Case Lowering Kit

#124006.....94JK43



#174001

Bump Stop Extensions

Extended Length Bump Stops
Black urethane bump stops - pair

1987-96

#174001.....34JK82

1997-01

#174002.....34JK82



#124014

Protection

TJ, XJ, ZJ Lower Control Arm Skid Plates

Weld-on lower control arm skid plates made of 3/16" steel to strengthen and protect the front lower arm pockets

#124014.....82JK23

Brake Lines

XJ Stainless Steel Brake Lines

DOT approved, Kevlar lined, 26" heavy-duty brake line. For 3"-6.5" of Lift.

Front

#104001.....89JK011

Rear

#104008.....07JK94

2" Upper Strut Mount Features

- This kit comes with new front upper strut mounts that add a small amount of pre-load as well as relocate the strut. This maintains the smooth stock ride while offering a little extra for off road performance
- Rear upper coil mounts increase height while maintaining factory ride



Vehicle Specs:
2" Lift Kit
265/70r17 MTZ
17x9 M/T Sidebiter
(Trimming required)



2005-2010 JEEP GRAND CHEROKEE WK/ COMMANDER XK 4WD

Lift & Method	Qty	Part#	Description	Recommended Accessories	Notes
2" Front / 1.5" Rear Upper Strut Mount Rear Coil Mount Kit #449H 65JK442	1	014201	Complete Box Kit		1

Notes

1. Strut compressor required for installation.

JEEP GRAND CHEROKEE WJ

PRO-RIDE SYSTEM

CHEVROLET/
GMC

DODGE

FORD

JEEP

SUZUKI

TOYOTA

POSI-LOK

SHOCKS/
STEERING
STABILIZERS

APPAREL/
PROMOTIONAL

PRODUCT
SPECS

VEHICLE
SPECS



Vehicle Specs:
4" Lift Kit
265/70R17 STZ
17" JK Wheels

System Features

- Front & rear Pro-Ride coil springs
- Front track bar bracket and pitman arm to correct steering angles and eliminate bump steer
- Front adjustable lower control arms to fine tune alignment
- Bump stop extensions
- Extended length rear sway bar links
- Rear upper tri-link spacer
- Transfer case drop kit for proper driveline angles



1999-2004 JEEP GRAND CHEROKEE WJ

Lift & Method	Qty	Part#	Description	Recommended Accessories	Notes
2" Front / 2" Rear	1	034203	Front Coil Springs	55409	1
Front Coil Springs	1	034207	Rear Coil Springs	124420	
Rear Coil Springs	2	55979	Front 5500 Shock	3100	
Kit #447H 45JK134	2	55970	Rear 5500 Shock		
4" Front / 3.5" Rear	1	014404	Box Kit	55409	2
Front Coil Springs	1	034401	Front Coil Kit	98224978	
Rear Coil Springs	1	034359	Rear Coil Kit	98224971	
Kit #448H	2	55978	Front 5500 Shock	55366	
88JK3711	2	55971	Rear 5500 Shock	95426	
				3104	JKS Quicker Disconnects

Notes

1. Vehicles equipped with V8 may not achieve stated lift height.
2. Front drive line modification may be required.

ACCESSORIES

Drive Line Adjustment

WJ Transfer Case Drop
#124027.....04JK94

Sway Bar Links

WJ Rear Solid Sway Bar Links
For 4" of Lift
#124409.....54JK24

Front Control Arms

Fixed Upper - (For 2"-4" of Lift)
#124441.....96JK421

Adjustable Upper - (For 2"-4" of Lift)
#124341.....97JK622

Adjustable Lower - (For 2"-4" of Lift)
#124420.....83JK453



#55366

Track Bar Components

WJ Front Track Bar
Relocation Bracket Kit

For 4" of Lift
#124402.....45JK931

JEEP GRAND CHEROKEE ZJ

PRO-RIDE SYSTEM

DODGE

FORD

JEEP

SUZUKI

TOYOTA

POSI-LOK

SHOCKS/
STEERING
STABILIZERS

APPAREL/
PROMOTIONAL

PRODUCT
SPECS

VEHICLE
SPECS



4.5" System Features

- Front and Rear adjustable upper control arms
- Front and Rear lower control arms
- Front adjustable track bar
- Rear track bar relocation system
- Front ultimate sway bar disconnects
- Rear sway bar links
- Front stainless Kevlar lined brake lines
- Bump stop extensions included

3" System Features

- 3" front / 2" rear Pro-Ride coils to level the stance
- Extended front sway bar links
- Front and rear track bar relocation brackets included to properly center the axle

1993-1998 JEEP GRAND CHEROKEE ZJ

Lift & Method	Qty	Part#	Description	Recommended Accessories	Notes
.75" Front/.75" Rear Front Coil Spacers Rear Coil Spacers Kit #443H 60JK842	1 2 2	024100 55979 55900	Spring Spacer Kit Front 5500 Shock Rear 5500 Shock	55401 98224979 98224900 2002	Single 5500 Steering Stabilizer FOX 2.0 Front Gas Shock (2 req'd) FOX 2.0 Rear Gas Shock (2 req'd) JKS Quicker Disconnects
1.75" Front/1.75" Rear Front Coil Spacers Rear Coil Spacers Kit #444H 77JK972	1 2 2	024202 55979 55950	Spring Spacer Kit Front 5500 Shock Rear 5500 Shock	55401 124306 2000 98224979 98224950	Single 5500 Steering Stabilizer Extended Frt Sway Bar Links JKS Quicker Disconnect Kit FOX 2.0 Front Gas Shock (2 req'd) FOX 2.0 Rear Gas Shock (2 req'd)
2" Front/2" Rear Front Coil Springs Rear Coil Springs Kit #445H 50JK164	1 1 2 2	034211 034208 55979 55950	Front Coil Springs Rear Coil Springs Front 5500 Shock Rear 5500 Shock		2
3" Front/2" Rear Front Coil Springs Rear Coil Springs Kit #446H 27JK185	1 1 1 2 2	034301 034208 124306 55965 55950	Front Coil Springs Rear Coil Springs Front Sway Bar Links Front 5500 Shock Rear 5500 Shock	55401 124327 124423 124451 2000 98224965 98224950	Single 5500 Steering Stabilizer Front Fixed LCA (rubber - pair) Order (1) 124081 spacer kit with 124327 control arm kit for ZJ Front Adjustable Track Bar Front Sway Bar Disconnect Kit JKS Quicker Disconnect Kit FOX 2.0 Front Gas Shock (2 req'd) FOX 2.0 Rear Gas Shock (2 req'd)
4.5" Front/4" Rear Front Coil Springs Rear Coil Springs Kit #445H 31JK3771	1 1 1 1 1 2 2	014462 124026 124451 034453 034409 55965 55920	Complete Box Kit Transfer Case Drop Kit Front Sway Bar Disconnect Kit Front Coil Springs Rear Coil Springs Front 5500 Shock Rear 5500 Shock	55401 2001 98224965 98224920	Steering Stabilizer JKS Quicker Disconnect Kit FOX 2.0 Front Gas Shock (2 req'd) FOX 2.0 Rear Gas Shock (2 req'd)

Notes

1. Measure front driveshaft, over 24-1/2" - no modifications should be necessary, 20 to 24" you may need to change to spicer type joint if vibration occurs. If driveshaft is less than 20" then a spicer type joint is required and vibration may persist.
2. Vehicles equipped with V8 may not achieve stated height.
3. If you do not want to drop the transfer case, an aftermarket slip yoke eliminator and CV style rear drive shaft is required.
4. If equipped with CV style drive shaft mount at front pinion, then a new spicer type joint is required to eliminate vibration.

JEEP GRAND CHEROKEE ZJ LONG ARM

CHEVROLET/
GMC

DODGE

FORD

JEEP

SUZUKI

TOYOTA

POSI-LOK

SHOCKS/
STEERING
STABILIZERS

APPAREL/
PROMOTIONAL

PRODUCT
SPECS

VEHICLE
SPECS



6.5" System Features

- True 4-Link long arm system for increased control in any offroad situation
- Heavy duty, high clearance belly pan included to protect your Jeep and increase frame rigidity
- New rear sway bar included to reduce body roll for on/off road performance
- Ultimate sway bar disconnects, stainless steel brake lines, adjustable front track bar, adjustable arms, extreme drop pitman arm, and a new steering stabilizer included
- No welding to the uni-body required

1993-1998 JEEP GRAND CHEROKEE ZJ

Lift & Method	Qty	Part#	Description	Recommended Accessories	Notes	
6.5" Front / 6" Rear	1	014661	Belly Pan Kit	55401	Single 5500 Steering Stabilizer	1
Front Long Arm	1	014662	Front Box Kit	98224961	FOX 2.0 Front Gas Shock (2 req'd)	2
Rear Long Arm	1	014669	Rear Box Kit	98224829	FOX 2.0 Rear Gas Shock (2 req'd)	3
STD Kit #459H	2	124653	Lower Standard Long Arms <i>or</i>			4
STD 17JK7222	2	124654	Lower Flex-End Long Arms			5
FLEX Kit #460H	1	034653	Front Coil Springs			
FLEX 95JK8732	1	034658	Rear Coil Springs			
	2	55961	Front 5500 Shock			
	2	55829	Rear 5500 Shock			

Notes

1. Slip yoke eliminator and CV style rear driveshaft required.
2. Will not work on vehicles equipped with NP249 transfer case.
3. Frame bracket modification required.
4. Will not work with manual transmission.
5. Exhaust modification may be required.

Upgrade System Features

- Front and rear 4-link long arm suspension system works with 4.5"-8.5" of lift.
- Heavy-duty, high clearance belly pan is designed to protect your Jeep and increase frame rigidity.
- Lower adjustable arms are available in both standard urethane and flex style ends.
- Optional replacement rear sway bar system.
- No welding is required.



1993-1998 JEEP GRAND CHEROKEE ZJ LONG ARM UPGRADE KIT

Lift & Method	Qty	Part#	Description	Recommended Accessories	Notes	
Kit #985H STD	1	124660	Front Long Arm Box Kit	124662	Rear Anti-Sway Bar	1
90JK7561 STD	1	124661	Rear Long Arm Box Kit			2
Kit #986H FLEX	2	124653	Lower Standard Long Arms <i>or</i>			3
18JK7571 FLEX	2	124654	Lower Flex Long Arms			

Notes

1. 93-95 models require #124038 Transmission Mount Bracket Kit.
2. Will not work with a manual transmission.
3. May require exhaust modification.



JEEP GRAND CHEROKEE ZJ ACCESSORIES

DODGE

FORD

JEEP

SUZUKI

TOYOTA

POSI-LOK

SHOCKS/
STEERING
STABILIZERS

APPAREL/
PROMOTIONAL

PRODUCT
SPECS

VEHICLE
SPECS



ZJ Front Control Arms

Upper Fixed Length with Rubber Bushings

#124441.....96JK421

Upper Fixed Length with Polyurethane Bushings

#124442.....00JK531

Upper Adjustable with Forged Flex Ends

#124341.....97JK622

Lower Fixed Length with Rubber Bushings

#124327*.....95JK451

Lower Fixed Length with Polyurethane Bushings

#124427*.....95JK451

Lower Adjustable with Forged Flex Ends
and Rubber Bushings

#124340*.....32JK903

Lower Adjustable with Forged Flex Ends
and Polyurethane Bushings

#124360*.....32JK903

*requires 124081 spacer washer kit



#124340



#124015

Shock Conversion

Shock Stem Eliminator

Allows use of eye-to-eye shock in stem-eye location

#124015.....13JK82

Bar Pin Eliminator

#124022.....47JK63

ZJ Rear Control Arms

Upper Fixed Length with Rubber Bushings

#124445.....13JK541

Upper Fixed Length with Polyurethane Bushings

#124446.....39JK561

Upper Adjustable with Forged Flex Ends
and Rubber Bushings

#124349.....27JK752

Upper Adjustable with Forged Flex Ends
and Polyurethane Bushings

#124447.....27JK752

Lower Fixed Length with Rubber Bushings

#124469.....09JK461

Lower Fixed Length with Polyurethane Bushings

#124468.....93JK181

Lower Adjustable with Forged Flex Ends
and Rubber Bushings

#124340.....32JK903

Lower Adjustable with Forged Flex Ends
and Polyurethane Bushings

#124360.....32JK903



#104001

Brake Lines

ZJ or XJ Stainless Steel Front Brake Lines

DOT approved, Kevlar lined, 26" heavy-duty brake line.

For 3"-6.5" of Lift.

#104001.....89JK011



#124423

Track Bar Components

XJ or ZJ Front Adjustable
Track Bar

Heavy-duty adjustable track bar to allow for properly centering the axle.

For 2"-4.5" of Lift

#124423.....48JK271

XJ or ZJ Front
Adjustable Track Bar

Must use with dropped pitman arm.

For 4.5"-6.5" of Lift

#124602.....56JK371

XJ or ZJ Front
Adjustable Track Bar

Must use with dropped pitman arm. Includes replacement frame mount bracket.

For 6"-9" of Lift

#124611.....17JK632

Rear Track Bar Bracket

For 2"-3" of Lift

#124209.....04JK33

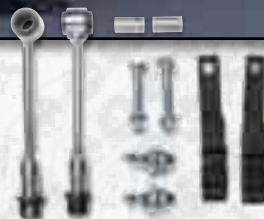

Sway Bar Links

ZJ or XJ Front

Ultimate Sway Bar Disconnect

On road stability and off-road performance. Easy one handed operation.

For 3"-4.5" of Lift

#124451.....08JK051

For 6.5" of Lift

#124652.....08JK051

ZJ or XJ Solid Front Sway Bar Link

For 2"-3" of Lift

#124306.....53JK18



#124014

Protection

TJ, XJ, ZJ

Lower Control Arm Skid Plates

Weld-on lower control arm skid plates made of 3/16" steel to strengthen and protect the front lower arm pockets

#124014.....82JK23



#174001

Bump Stop Extensions

Extended Length Bump Stops

Front Bump Stops - Black

#174001.....34JK82

Rear Bump Stops - Blue - 3"

#172501.....20JK75

JEEP LIBERTY KJ PRO-RIDE SYSTEM



- Front strut extensions included to increase wheel travel and maintain ride quality
- Front and rear Pro-Ride coil springs
- Rear shock included with CAV technology
- Front box/coil kit includes: Pro-Ride front coil springs and strut relocation brackets to maintain full wheel travel

2002-2007 JEEP LIBERTY KJ

Lift & Method	Qty	Part#	Description	Recommended Accessories	Notes
2" Front / 1.5" Rear	1	034201	Front Box/Coil Springs		1
Front Coil Springs	1	034205	Rear Coil Springs		2
Rear Coil Springs	2	55968	Rear 5500 Shock		
Kit #442H 40JK164					

1. Will not work with diesel or hybrid models.
2. Strut compressor required for installation.



For more on BDS Project KJ build head to bds-suspension.com/blog

PROJECT
KJ



JEEP COMANCHE MJ PRO-RIDE SYSTEM

3" System Features:

- 3" Pro-Ride coil springs and rear add-a-leaves
- Transfer case lowering kit corrects driveline vibration

1986-1992 JEEP COMANCHE TRUCK MJ 2WD & 4WD

Lift & Method	Qty	Part#	Description	Recommended Accessories	Notes
.75" Front / 1" Rear	1	174101	Front Coil Spacers	55401	Single 5500 Steering Stabilizer
Front Coil Spacers	1	124107	Rear 1" Shackles		
Rear Shackles	2	55960	Front 5500 Shock		
Kit #484H 13JK213	2	55972	Rear 5500 Shock		
1.75" Front / 2" Rear	1	024201	Front Spacer Kit	55401	Single 5500 Steering Stabilizer
Front Coil Spacers	1	114202	Rear Add-A-Leaf Kit	124006	Transfer Case Lowering Kit
Rear Add-A-Leafs	4	4012	U-bolt kit—Chrysler type 8-1/4 rear axle or	PSL900	4x4 Posi-Lok™ (page 119)
8.25 Axle Kit #436H	4	4005	U-bolt kit—Dana 35 rear axle		
Dana Axle Kit #437H	2	55960	Front 5500 Shock		
36JK683	2	55920	Rear 5500 Shock (MJ)		
2" Front / 2" Rear	1	034211	Front Coil Springs		1
Front Coil Springs	1	114202	Add-A-Leaf Kit		2
Rear Add-A-Leafs	4	4012	U-bolt kit—Chrysler type 8-1/4 rear axle or		
8.25 Axle Kit #438H	4	4005	U-bolt kit—Dana 35 rear axle		
Dana Axle Kit #439H	2	55960	Front 5500 Shocks		
97JK514	2	55920	Rear 5500 Shocks (MJ)		
3" Front / 2.5" Rear	1	034301	Front Coil Springs	55401	Single 5500 Steering Stabilizer
Front Coil Springs	1	114202	Rear Add-A-Leaf Kit (MJ)	124317	Front Lower Control Arms (Pair)
Rear Add-A-Leafs & Block	1	124006	Transfer Case Drop Kit	124423	Front Adjustable Track Bar
8.25 Axle Kit #440H	1	124306	Extended Anti-Sway Bar Links	PSL900	4x4 Posi-Lok™ (page 119)
Dana Axle Kit #441H	4	4012	U-bolt kit—Chrysler type 8-1/4 rear axle or	98224965	FOX 2.0 Front Gas Shock (2 req'd)
59JK075	4	4005	U-bolt kit—Dana 35 rear axle	98224920	FOX 2.0 Rear Gas Shock (2 req'd)
	2	55965	Front 5500 Shock		
	2	55920	Rear 5500 Shock (MJ)		

Notes

1. Measure the rear u-bolts before ordering. Some MJ's are equipped with a Dana 44 rear axle.
2. Transfer case lowering kit is not required for 2WD models.

SUZUKI SAMURAI

GLIDE-RIDE SYSTEM



- Pictured Right—Glide-Ride leaf springs feature tapered ends with anti-friction pads and bolt style leaf alignment clamps
- New urethane bushings included for long life and increased control

1985-1995 SUZUKI SAMURAI

Lift & Method	Qty	Part#	Description	Recommended Accessories	Notes	
4" Front / 4" Rear	2	007401	Front Spring	55403	Single 5500 Steering Stabilizer	1
Front Leaf Springs	2	007409	Rear Spring	55307	Steering Stabilizer Mounting Kit	2
Rear Leaf Springs	1	017400	Box Kit	087401	Pitman Arm (PS)	
Kit #701H	2	55800	Front 5500 Shock	124101	Front Shackles 1/2" lift	
59SK187	2	55950	Rear 5500 Shock	127059	Rear Shackles 1/2" lift	

Notes

1. Cannot reinstall front sway bar on 88-1/2 or newer vehicles.
2. Pitman arm required to center steering wheel.

SUZUKI SIDEKICK & GEO TRACKER

PRO-RIDE SYSTEM



- BDS Pro-Ride coil springs are capable of being smashed totally flat and still return to the proper ride height
- CNC machined strut extensions are included that will return your OE strut to the center of wheel travel to ensure off road capability.
- Offset strut cam bolts are included in order to ensure that a proper alignment can be done.

1988-1998 SUZUKI SIDEKICK 2 DOOR SWB & GEO TRACKER

Lift & Method	Qty	Part#	Description	Recommended Accessories	Notes
2" Front / 2" Rear	1	037201	Front Coil Springs		
Front Coil Springs	1	037209	Rear Coil Springs		
Rear Coil Springs	2	55930	Rear 5500 Shock		
Kit #702H					
61SK284					



TOYOTA





2005-2014 TOYOTA TACOMA 4WD

- Ductile iron steering knuckles
- 1/4" thick steel front and rear crossmembers, tied together with a 1-piece full belly skid, to provide rigidity and strength as well as protect the front differential components
- The factory front struts are retained and relocated with heavy duty upper strut mounts
- Rear lift block system to properly match the front and rear ride heights



Vehicle Specs:
6" Lift Kit
35" M/T ATZ
18x9" XD Addict

2005-2014 TOYOTA TACOMA 4WD

Lift & Method	Qty	Part#	Description	Recommended Accessories	Notes	
2.5" Front / 0" Rear Strut Spacer Kit #817H 167K611	1	028251	Strut Spacer Kit	55954 98224954 018218	Rear 5500 Shock (2 req'd) FOX 2.0 Rear Gas Shock (2 req'd) 2" Rear Block Kit	
4" Front / 3" Rear HC System Block Kit Kit #816H 01TK3571	1 1 1 1 1 2	028600 028601 028602 028403 018318 55954	Front Box 1 of 4 Front Box 2 of 4 Front Box 3 of 4 Front Box 4 of 4 - 4" Only 3" Rear Block Kit Rear 5500 Shock	98224954 	FOX 2.0 Rear Gas Shock (2 req'd)	1 2 4 5 6 7 8
6" Front / 4" Rear HC System Block Kit Kit #815H 87TK0081 Kit #815F 98TK4833	1 1 1 1 1 2 2	028600 028601 028602 018408 028603 or 88302048 55953 or 98224953	Front Box 1 of 4 Front Box 2 of 4 Front Box 3 of 4 4" Rear Block Kit Front Box 4 of 4 or FOX 2.5 Coilover Kit Rear 5500 Shock or FOX 2.0 Rear Gas Shock	98224953 	FOX 2.0 Rear Gas Shock (2 req'd)	1 2 3 4 5 7 8

Notes

1. Minor welding required
2. Requires frame bracket modification
3. Strut compressor required for installation
4. Stock wheels cannot be reinstalled
5. System will work on 2WD PreRunner models
6. 2013-2014 models require FOX Shock upgrade to clear rear axle tube.
7. Can not use 17" wheels.
8. Some 2014 models may not achieve net lift height stated, but will have the same lift stance of equally equipped 2005-2013 models.



1995.5-2004 TOYOTA TACOMA 4WD



- One piece new upper strut mount creates pre-load and top spacer all in one
- Long thin rear add-a-leaf
- 5500 series rear shocks

1995.5-2004 TOYOTA TACOMA 4WD

Lift & Method	Qty	Part#	Description	Recommended Accessories	Notes
2.5" Front / 2" Rear	1	028250	Front Box Kit	128005 Differential Drop Kit	1
Front Upper Strut Mount	1	018219	Rear Add-A-Leaf		
Rear Add-A-Leaf	2	55878	Rear 5500 Shock		
Kit #808H 59TK583					

Notes

1. Strut compressor required for installation

2007-2014 TOYOTA FJ CRUISER PRO-RIDE SYSTEM



- One piece upper strut mount creates a top spacer with pre-load built in
- The rear includes new "Pro-Ride" coils capable of full coil bind
- New extended length rear sway bar links work with the new coil springs to offer extreme droop

2007-2014 FJ CRUISER 2WD/4WD

Lift & Method	Qty	Part#	Description	Recommended Accessories	Notes
3" Front / 2" Rear	1	018300	Box Kit		1
Front Upper Strut Mount	1	038209	Rear Coil Springs		
Rear Coil Springs	2	55879	Rear 5500 Shock		
Kit #809H 22TK954					

1. Strut compressor required for installation.

Vehicle Specs:
3" Lift Kit
33" Hankook M/T
17" Alloy Wheels





2000-2014 TOYOTA TUNDRA 4WD



7" Kit Features

- Lower Strut Mounts or FOX 2.5 Remote Coilovers
- One Piece High Clearance Crossmembers
- Full Belly Skid offers extra protection
- Ductile Iron Steering Knuckles
- HD Tie Rod Ends

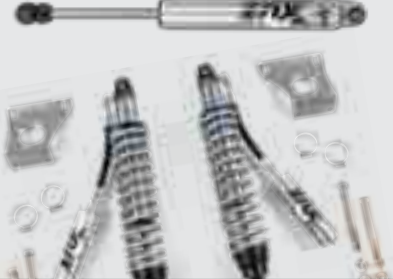
2007-2014 TOYOTA TUNDRA 4WD & 2WD

Lift & Method	Qty	Part#	Description	Recommended Accessories	Notes
3" Front / 0" Rear Front Upper Strut Mount Kit #810H 79TK611	1	028300	Front Box Kit	55700 Rear 5500 Shock (2 req'd) 98224700 FOX 2.0 Rear Gas Shock (2 req'd) 128109 Rear 1" Shackle Kit 018208 2" Rear Block Kit 128006 Differential Drop Kit	3
4.5" Front / 3" Rear IFS w/ Strut Mount Kit# 814H 52JK9091	1	028700	Front Box Kit 1 of 5	98224952 FOX 2.0 Rear Gas Shock (2 req'd)	1
	1	028701	Front Box Kit 2 of 5	128409 Carrier Bearing Drop	3
	1	028702	Front Box Kit 3 of 5	128109 Rear 1" Shackle Kit	4
	1	028703	Front Box Kit 4 of 5		5
	1	028454	Front Box Kit 5 of 5		6
	1	018319	Rear Box Kit		7
	2	55952	Rear 5500 Shock		
7" Front / 4" Rear IFS w/ Strut Mount Kit# 813H 54TK8891 Kit# 813F 89TK7563	1	028700	Front Box Kit 1 of 5	 #88302057	1
	1	028701	Front Box Kit 2 of 5		2
	1	028702	Front Box Kit 3 of 5		4
	1	028703	Front Box Kit 4 of 5		5
	1	018409	Rear Box Kit		6
	1	028704 or	Front Box Kit 5 of 5 or		
	1	88302057	FOX 2.5 Coilover Kit		
	1	128700	Mounting Kit		
	2	55952 or	Rear 5500 Shock or		
	2	98224952	FOX 2.0 Rear Gas Shock		

2000-2006 TOYOTA TUNDRA 4WD

Lift & Method	Qty	Part#	Description	Recommended Accessories	Notes
2.5" Front / 1" Rear Front Upper Strut Mount Rear Block Kit Kit #807H 01TK042	1	028252	Front Box Kit	018209 Rear 2" Block Kit 128005 Differential Drop Kit	2

Notes

1. Requires frame bracket modification and welding.
2. Strut compressor required for installation.
3. No strut disassembly required.
4. Stock 17", 18", and 20" wheels cannot be reinstalled.
5. Models with two piece rear driveline will require rear driveline modification.
6. Rear shackle kit can be added for 1" additional lift.

ACCESSORIES



Vehicle Specs:
7" Lift Kit
35x12.50 Hankook M/T
18x10 2Crave Wheels



What Is 4x4 Posi-Lok™?

- A permanent replacement of the failure prone O.E. vacuum and electric front axle engagement systems.
- Allows you to engage the front axle from inside the cab.
- Engagement every time because you are in direct control.
- A one-inch pull of the cable ensures you will have 4-wheel drive when you need it, as long as the transfer case is engaged.
- It is not a posi-trac or locker.
- Simple and easy to install.
- A patented front axle engagement system.

4X4 Posi-Lok™ Benefits

- Provides the benefits of 2-wheel drive low range, giving the vehicle 4-LO torque at the rear axles with bind free steering only available in 2-HI. This feature is not available with factory systems and is beneficial when maneuvering trailers.
- Reduces front differential wear and right axle breakage.
- Will not disengage when the ignition is turned off or the differential is submerged.
- Compatible with manual or electric transfer cases and complete installation can be completed in one to two hours with basic hand tools. No internal differential work required.

4x4 Posi-Lok™ 4WD Engagement Systems

Model	Year	Kit#	Notes
CHEVROLET/GMC K SERIES			
1500, 2500 Truck 6 Lug	1988-1998	600	1
Suburban, Tahoe, Yukon 6 Lug	1992-1998	600	
2500, 3500 Truck 8 Lug	1988-1998	800	
Suburban 8 Lug	1992-1998	800	
CHEVROLET/GMC S SERIES			
S-10, S-15 Truck, Blazer, Jimmy including ZR2 and Highrider	1983-2004	500	2
DODGE			
Ram 1500 w/ Dana 44-60	1994-2001	400	2, 6
Ram 2500, 3500 w/ Dana 44-60	1994-2002	400	
W-Series Truck, Ramcharger, Trailduster	1985-1993	450	2, 6
FORD			
F-150 4WD	1997-2003	750	2
JEEP			
Wrangler YJ	1987-1995	900 or 920	3, 4
Cherokee XJ	1984-1991	900 or 920	
Comanche MJ	1986-1991	900 or 920	
4X4 PERM-LOK			
Chevrolet/GMC K Series applications		1000	
Dodge 1/2, 3/4 Ton Truck	1985-2001	1100	5
Jeep Wrangler YJ - Dana 30		1100	
Jeep Cherokee XJ - Dana 30		1100	
Jeep Comanche MJ - Dana 30		1100	
OPTIONAL ACCESSORY			
Heavy-duty, cast iron fork with pads for Dodge and Jeep application		100	

Notes

1. With Thermal Linear Actuator (TLA)
2. With Vacuum Actuator
3. With Dana 30 Central Axle Disconnect (CAD)
4. Order part #920 for lifted applications over 3"
5. Manual hubs recommended
6. PSL100 will not fit Dana 60 M front axle



www.4x4posi-lok.com



2.5 COILOVER SHOCKS

DODGE

FORD

JEEP

SUZUKI

TOYOTA

POSI-LOK

SHOCKS/
STEERING
STABILIZERS

APPAREL/
PROMOTIONAL

PRODUCT
SPECS

VEHICLE
SPECS

Application	Part Number	Base Lift Height	Note
2014 Ford F150	883-02-114	6"	1,2
09-13 Ford F150	883-02-063	6"	1,2
07-13 Chevy 1500	883-02-059	6"	1,2
06-13 Dodge 1500	883-02-073	6"	1,2
05-13 Toyota Tacoma	883-02-048	6"	1,2
07-13 Toyota Tundra	883-02-057	7"	1,2,3

- Notes**
1. Designed to work with BDS Suspension lifts
 2. Fully Adjustable Coil Over Assembly
 3. Requires Mounting Kit #128700



Spanner Wrench

The spanner wrench is a pin-style design that is precision machined to fit in the Fox 2.5 Coilover adjustment collar holes. This precise fit provides the best grip and reduces the chance of damage to the tool, adjustment collar and your knuckles. The tool was designed to accept any standard 1/2" drive ratchet (sold separately) for ease of use.

#BDS129600.....53BK31

FOX LIMITED WARRANTY FOX Factory, Inc., a California corporation having offices at 130 Hangar Way, Watsonville, CA 95076 ("FOX"), makes the following LIMITED WARRANTY with respect to its suspension products:

LIMITED ONE (1) YEAR WARRANTY ON SUSPENSION PRODUCTS Subject to the limitations, terms and conditions hereof, FOX warrants, to the original retail owner of each new FOX suspension product, that the FOX suspension product, when new, is free from defects in materials and workmanship. Unless otherwise required by law, this warranty expires one (1) year from the date of the original FOX suspension product retail purchase from an authorized FOX dealer or from a FOX authorized Original Equipment Manufacturer where FOX suspension is included as original equipment on a purchased vehicle. If law requires a warranty duration of greater than one (1) year, then, subject to the other provisions hereof, this warranty will expire at the end of the minimum warranty period required by such law.

TERMS OF WARRANTY

This warranty is conditioned on the FOX suspension product being operated under normal conditions and properly maintained as specified by FOX. This warranty is only applicable to FOX suspensions purchased new from an authorized FOX source and is made only to the original retail owner of the new FOX suspension product and is not transferable to subsequent owners. This warranty is void if the FOX suspension product is subjected to abuse, neglect, improper or unauthorized repair, improper or unauthorized service or maintenance, alteration, modification, accident or other abnormal, excessive, or improper use.

Should it be determined by FOX in its sole and final discretion, that a FOX suspension product is covered by this warranty, it will be repaired or replaced, by a comparable model, at FOX's sole option, which will be conclusive and binding. **THIS IS THE EXCLUSIVE REMEDY UNDER THIS WARRANTY.**

ANY AND ALL OTHER REMEDIES AND DAMAGES THAT MAY OTHERWISE BE APPLICABLE ARE EXCLUDED, INCLUDING, BUT NOT LIMITED TO, INCIDENTAL OR CONSEQUENTIAL DAMAGES OR PUNITIVE DAMAGES.

This limited warranty does not apply to normal wear and tear, malfunctions or failures that result from abuse, improper assembly, neglect, alteration, improper maintenance, crash, misuse or collision. This limited warranty gives the consumer specific legal rights. The consumer may also have other legal rights which vary from state to state or country to country. Some states and countries do not allow the exclusion or limitation of incidental or consequential damages or warranties, and if dictated by law the above limitations or exclusions may not apply to you. If it is determined by a court of competent jurisdiction that a certain provision of this limited warranty does not apply, such determination shall not affect any other provision of this limited warranty and all other provisions shall remain in full effect.

THIS IS THE ONLY WARRANTY MADE BY FOX ON ITS SUSPENSION PRODUCTS AND COMPONENTS, AND THERE ARE NO WARRANTIES WHICH EXTEND BEYOND THE DESCRIPTION HEREIN. ANY WARRANTIES THAT MAY OTHERWISE BE IMPLIED BY LAW INCLUDING, BUT NOT LIMITED TO, ANY IMPLIED WARRANTY OF MERCHANTABILITY OR FITNESS FOR A PARTICULAR PURPOSE ARE EXCLUDED.



2.0 PERFORMANCE SERIES SHOCK

CHEVROLET/
GMC

DODGE

FORD

JEEP

SUZUKI

TOYOTA

POSI-LOK

SHOCKS/
STEERING
STABILIZERS

APPAREL/
PROMOTIONAL

PRODUCT
SPECS

VEHICLE
SPECS

DIRECT REPLACEMENT HIGH-PERFORMANCE 2" SHOCK ENGINEERED SPECIFICALLY FOR YOUR BDS SUSPENSION SYSTEM

APPLICATION SPECIFIC VALVING

- Fox and BDS joined forces to custom valve each application to work perfectly with each BDS Suspension system. The basic shock design is based on Fox Racing Shox race products, but re-designed to turn your BDS equipped truck or Jeep into an offroad machine.

HEAT-REDUCING DESIGN

- Cold-forged, metal impacted 6061 T6 aluminum shock body dissipates heat three times faster than a conventional steel body shock. The 2.0 Performance Series shock runs as cool as a 2.5 diameter shock on the same application.
- FOX Racing Shox formulated race shock oil developed for ultimate performance at variable temperatures.

TOUGH FINISH

- CNC machined aluminum components are Type II hard anodized to a scratch- and fade-free black finish.
- Heavy-duty 5/8" chrome shafts are induction case hardened to over 55 Rockwell C, virtually eliminating scratches caused by roost and debris.

FADE-FREE PERFORMANCE

- The Internal Floating Piston (IFP) design separates shock oil from the high pressure nitrogen charged gas chamber, eliminating oil aeration and cavitation, while providing a predictable ride — capable of handling the roughest conditions with fade-free performance.

CHEVROLET/GMC 4WD

Model	Year	Lift	Front Shock	Rear Shock
Truck K1500/C1500	2014	0-2"	n/a	98224719
		4"	n/a	98224759
		6"	n/a	98224759
Truck K1500/C1500	07-13	0"	n/a	98224719
		4"	n/a	98224758
		6"	n/a	98224759
Truck K1500	99-06	4.5"	98224602	98224758
		6.5"	98224602	98224759
Truck K2500 HD & Non-HD	11-15	6.5"	98224613	98224768
	01-10	4.5"	98224605	98224759
		7"	98224606	98224761
Truck C2500 HD (2WD)	01-10	6"	98224605	98224761
Trailblazer/Envoy (2WD/4WD)	02-09	2"	n/a	98224619
Truck K10, 20, 30	73-87	2.5"	98224620	98224629
		4"	98224620	98224639
		6-8"	98224650	98224639
	69-72	4"	98224620	98224660
Tahoe, Yukon, Suburban, Avalanche, 1500	07-14	0-2"	n/a	98224719
		6"	n/a	98224759
	00-06	4.5"	98224602	98224758
		6.5"	98224602	98224759
Suburban, Avalanche 2500	01-06	7"	98224606	98224761
Blazer, Jimmy K5, Suburban 10, 20	73-91	2.5"	98224620	98224629
		4"	98224620	98224639
		6-8"	98224650	98224639

Notes: 1. With BDS Suspension system

CHEVROLET/GMC 4WD with OE Front Dual Shocks

Model	Year	Lift	Front Shock	Front Auxiliary	Rear Shock
Truck K10, 20, 30	81-87	2.5"	98224620	98224620	98224629
		4"	98224620	98224650	98224639
		6"	98224650	98224650	98224639
		8"	98224650	98224660	98224639
Blazer, Jimmy K5, Suburban 10, 20	81-91	2.5"	98224620	98224620	98224629
		4"	98224620	98224650	98224639
		6"	98224650	98224650	98224639
		8"	98224650	98224660	98224639

FOX 2.0 Performance Series Shocks Continued ►



DODGE 4WD

Model	Year	Lift	Front Shock	Rear Shock
Ram Truck 1/2-Ton	09-14	4"	n/a	98224758
		6"	n/a	98224759
		0"	n/a	98224719
	06-08	4"	n/a	98224758
		6"	n/a	98224769
		2-3"	98224700	98224759
Ram Truck 1/2-Ton - Mega Cab	06-08	6"	98224750	98224761
Ram Truck 1/2-Ton	94-01	0-2"	98224710	98224719
		3"	98224700	98224759
Ram Truck 3/4-Ton	2014	5"	98224750	98224761
		2"	98224710	98224705
Ram Truck 3/4-Ton	03-13	4"	98224752	98224705
		6"	98224752	98224756
Ram Truck 3/4-Ton	03-13	2-3"	98224700	98224759
		6"	98224750	98224761
		8"	98224751	98224761
Ram Truck 1-Ton	13-14	2"	98224710	98224759
		4"	98224752	98224759
		6"	98224752	98224761
Ram Truck 1-Ton	03-12	2-3"	98224700	98224759
		6"	98224750	98224761
		8"	98224751	98224761
Ram Truck 3/4-Ton Power Wagon	05-13	4"	98224751	98224761
Ram Truck 3/4-Ton	94-02	0-2"	98224710	98224719
Ram Truck 3/4-Ton-8,800 GVW	94-02	0-2"	98224700	98224719
Ram Truck 3/4-Ton	94-02	4-5"	98224750	98224761
"W" Truck 1/2-Ton, 3/4-Ton	69-93	5"	98224650	98224760

FORD 4WD

Model	Year	Lift	Front Shock	Rear Shock
Expedition	98-02	6"	98224804	98224628
F-150	04-14	0"	n/a	98224651
		4"	n/a	98224828
		6"	n/a	98224760
F-250, F-350 Super Duty	97-03	6"	98224804	98224860
		0-2"	98224710	98224660
		4"	98224700	98224760
	05-14	6"	98224750	98224760
		8"	98224751	98224765
		2.5"	98224650	98224660
99-04	4"	98224650	98224760	
	6"	98224660	98224760	
	8"	98224660	98224765	
F-350	80-97	4"	98224650	98224660
Excursion		4"	98224650	98224762
00-05	00-05	6"	98224650	98224762
		8"	98224660	98224762
		10"	98224660	98224766

JEEP 4WD

Model	Year	Lift	Front	Rear Shock
CJ5, CJ7, Scrambler	82-86	2.5"	98224900	98224950
		4"	98224920	98224920
		4"	98224900	98224920
CJ5, CJ6, M38A1	53-75	2.5"	98224900	98224900
Wrangler YJ	87-95	5-6"	98224660*	98224920
Wrangler TJ		2"	98224979	98224972
Wrangler JK	97-06	3"	98224965	98224980
		4.5"	98224967	98224976
		6.5"	98224962	98224974
		2-3"	98224921	98224951
07-14	07-14	4.5"	98224922	98224959
		5.5"	98224922	98224958
		6.5"	98224952	98224958
		0-2"	98224979	98224972
Cherokee XJ	84-01	3"	98224965	98224980
		4.5"	98224965	98224974
		2"	98224979	98224920
Comanche MJ	86-92	3"	98224965	98224920
		0-1"	98224979	98224900
Grand Cherokee ZJ	93-98	2"	98224979	98224950
		3"	98224965	98224950
		4.5"	98224965	98224920
		6.5"	98224961	98224829
Grand Cherokee WJ	99-04	2"	98224979	98224970
		4"	98224978	98224971

* Stem eliminator kit #124015 required for installation

TOYOTA 4WD

Model	Year	Lift	Front Shock	Rear Shock
Toyota Tundra	07-14	0"	n/a	98224700
		4"	n/a	98224952
Toyota Tacoma	05-14	2-3"	n/a	98224954
		4-5"	n/a	98224953



5500 SERIES SHOCK ABSORBERS

CHEVROLET/
GMC

DODGE

FORD

JEEP

SUZUKI

TOYOTA

POSI-LOK

SHOCKS/
STEERING
STABILIZERS

APPAREL/
PROMOTIONAL

PRODUCT
SPECS

VEHICLE
SPECS

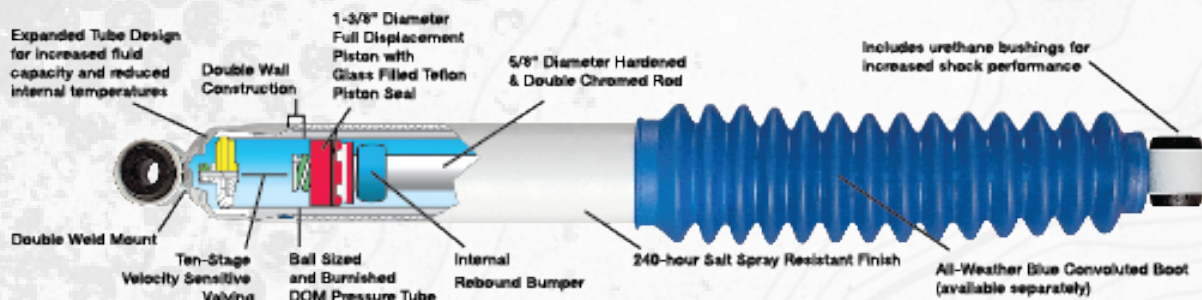

Correct Application Valving Technology is based on extensive shock dyno and ride control research offering the most application specific part numbers available for on and off-road light trucks and SUV's.

THIS RESULTS IN:

- Increased stability for improved handling
- Longer front end and tire life
- Less nose dive on severe braking
- Less squat on hard acceleration
- Smoother ride—control without harshness

CHEVROLET/GMC 4WD

Model	Year	Lift	Front Shock	Rear Shock
Truck K1500/C1500	07-14	0"	n/a	55719
Truck K1500/C1500	07-14	4"	n/a	55758
Truck K1500/C1500	07-14	6"	n/a	55759
Truck K1500	99-06	0"	55612	55719
Truck K1500	99-06	4.5"	55602	55758
Truck K1500 (Non HD)	99-06	6"	55602	55759
Truck C1500 (2WD-Non HD)	99-06	6"	55604	55759
Truck K2500 HD	11-15	6.5"	55613	55768
Truck K2500 HD & Non-HD	01-10	7"	55606	55761
Truck K2500 HD & Non-HD	01-10	4.5"	55605	55759
Truck C2500 HD (2WD)	01-10	6"	55605	55761
Hummer H2	03-08	6"	55605	55761
Truck K1500-3500	88-98	0-3"	55601	55608 2
Truck K1500 6 lug	88-98	6"	55600	55609
Truck K10, 20, 30	73-87	2.5"	55620	55629
Truck K10, 20, 30	73-87	4"	55620	55639
Truck K10, 20, 30	73-87	6-8"	55650	55639
Truck K10, 20, 30	69-72	4"	55620	55660
Tahoe, Yukon, Suburban, Avalanche, 1500	07-13	0-3"	n/a	55719
Tahoe, Yukon, Suburban, Avalanche, 1500	07-13	6"	n/a	55759
Tahoe, Yukon, Suburban, Avalanche, 1500	00-06	4"	55602	55758
Tahoe, Yukon, Suburban, Avalanche, 1500	00-06	6"	55602	55759
Suburban, Avalanche 2500	01-06	7"	55606	55761
Tahoe, Yukon, Suburban 1500, 2500 6 lug	92-98	0-3"	55601	55608
Tahoe, Yukon, Suburban 1500, 2500 6 lug	92-98	6"	55600	55609
Blazer, Jimmy K5, Suburban 10, 20	73-91	2.5"	55620	55629
Blazer, Jimmy K5, Suburban 10, 20	73-91	4"	55620	55639
Blazer, Jimmy K5, Suburban 10, 20	73-91	6-8"	55650	55639
Trailblazer	02-09	2"	n/a	55619
S-Series Blazer, Truck, ZR2	83-05	0-3"	55603	55608
S-Series Blazer, Truck, ZR2	83-05	5"	55610	55608 1

Notes

1. With BDS Suspension system

2. These applications are for newer body style K3500 with torsion bar front suspension.

CHEVROLET/GMC with OE Front Dual Shocks 4WD

Model	Year	Lift	Front Shock	Front Auxiliary	Rear Shock
Truck K10, 20, 30	81-87	2.5"	55620	55620	55629
Truck K10, 20, 30	81-87	4"	55620	55650	55639
Truck K10, 20, 30	81-87	6"	55650	55650	55639
Truck K10, 20, 30	81-87	8"	55650	55660	55639
Blazer, Jimmy K5, Suburban 10, 20	81-91	2.5"	55620	55620	55629
Blazer, Jimmy K5, Suburban 10, 20	81-91	4"	55620	55650	55639
Blazer, Jimmy K5, Suburban 10, 20	81-91	6"	55650	55650	55639
Blazer, Jimmy K5, Suburban 10, 20	81-91	8"	55650	55660	55639

Note: The front auxiliary is the inner long shock.

Boots ordered separately

DODGE 4WD

Model	Year	Lift	Front Shock	Rear Shock
Ram Truck 1/2 Ton	09-14	4"	n/a	55758
Ram Truck 1/2 Ton	09-14	6"	n/a	55759
Ram Truck 1/2 Ton	06-08	0"	n/a	55719
Ram Truck 1/2 Ton	06-08	4"	n/a	55758
Ram Truck 1/2 Ton	06-08	6"	n/a	55769
Ram Truck 1/2 Ton - Mega Cab	06-08	2-3"	55700	55759
Ram Truck 1/2 Ton - Mega Cab	06-08	6"	55750	55761
Ram Truck 1/2 Ton	02-05	6"	55711	55769
Ram Truck 1/2 Ton	94-01	0-2"	55710	55719
Ram Truck 1/2 Ton	94-01	3"	55700	55759
Ram Truck 1/2 Ton	94-01	5"	55750	55761
Ram Truck 3/4 Ton	03-13 (2500) 03-12 (3500)	2-3"	55700	55759
Ram Truck 3/4 Ton, 1 Ton	03-13 (2500) 03-12 (3500)	6"	55750	55761
Ram Truck 3/4 Ton, 1 Ton	03-13 (2500) 03-12 (3500)	8"	55751	55761
Ram Truck 3/4 Ton	2014	0-2"	55710	55705
Ram Truck 3/4 Ton	2014	4"	55752	55752
Ram Truck 3/4 Ton	2014	6"	55752	55756
Ram Truck 1 Ton	13-14	0-2"	55710	55759
Ram Truck 1 Ton	13-14	4"	55752	55759
Ram Truck 1 Ton	13-14	6"	55752	55761
Ram Truck 3/4 Ton Power Wagon	05-12	4"	55751	55761
Ram Truck 3/4 Ton	94-02	0-2"	55710	55719
Ram Truck 3/4 Ton-8,800 GVW	94-02	0-2"	55700	55719
Ram Truck 3/4 Ton	94-02	4-5"	55750	55761
"W" Truck 1/2, 3/4 Ton	69-93	5"	55650	55760

FORD 4WD

Model	Year	Lift	Front Shock	Rear Shock
Ranger	83-97	4"	55800	55829
Ranger	83-97	6"	55820	55829
Bronco II	82-91	4"	55800	55650
Bronco II	82-91	6"	55820	55829
Expedition	98-02	6"	55804	55628
F-150	04-14	0"	n/a	55651
F-150	04-14	4"	n/a	55828
F-150	04-14	6"	n/a	55760
F-150	97-03	0-1"	55805	55850
F-150	97-03	6"	55804	55860
F-150 - 4WD	80-96	0-1"	55805	55620
F-150 - 4WD	80-96	1-2"	55810	55620
F-150 - 4WD	80-96	4"	55800	55660
F-150 - 4WD	80-96	6"	55820	55660
F-150 - 2WD	80-96	1-2"	55810	55620
F-150 - 2WD	80-96	4"	55800	55650
F-150 - 2WD	80-96	6"	55820	55650
F-150	77-79	4"	55820	55850
F-150	77-79	6"	55850	55860
F-150	73-76	4"	55875	55850
F-150	73-76	6"	55877	55860
Bronco	80-96	0-1"	55805	55620
Bronco	80-96	1-2"	55810	55620
Bronco	80-96	4"	55800	55650
Bronco	80-96	6"	55820	55650
Bronco	78-79	4"	55850/55820**	55650
Bronco	78-79	6"	55860/55850**	55650
F-250, F-350 Super Duty	05-14	0-2"	55710	55660
F-250, F-350 Super Duty	05-14	4"	55700	55760
F-250, F-350 Super Duty	05-14	6"	55750	55760
F-250, F-350 Super Duty	05-14	8"	55751	55765
F-250, F-350 Super Duty	99-04	0-2"	55620	55660
F-250, F-350 Super Duty	99-04	2.5"	55650	55660
F-250, F-350 Super Duty	99-04	4"	55650	55760
F-250, F-350 Super Duty	99-04	6"	55660	55760
F-250, F-350 Super Duty	99-04	8"	55660	55765
F-250	87-96	4"	55650	55660
F-250	80-86	4"	55820	55660
F-350	80-97	4"	55650	55660
Excursion	00-05	0-2"	55620	55662
Excursion	00-05	4"	55650	55762
Excursion	00-05	6"	55650	55762
Excursion	00-05	8"	55660	55762
Excursion	00-05	10"	55660	55766

** Order one each front shock w/ staggered mounts.

FORD with OE Front Dual Shocks 4WD

Model	Year	Lift	Front Shock	Front Auxiliary	Rear Shock
F-150, Bronco	80-96	0-1"	55805	55810	55620
F-150, Bronco	80-96	1-2"	55810	55800	55620
F-150	80-96	4"	55800	55820	55660
F-150	80-96	6"	55820	55819	55660
F-150	78-79	4"	55820	55819	55850
F-150	78-79	6"	55850	55860	55860
Bronco	80-96	4"	55800	55820	55650
Bronco	80-96	6"	55820	55819	55650

Note: Front auxiliary is the shock forward of the front axle.

JEEP 4WD

Model	Year	Lift	Front Shock	Rear Shock
CJ5, CJ6, M38A1	53-75	2.5"	55900	55900
CJ5, CJ7, Scrambler	82-86	2.5"	55900	55950
CJ5, CJ7, Scrambler	76-81	2.5"	55910	55950
CJ5, CJ7, Scrambler	82-86	4"	55920	55920
CJ5, CJ7, Scrambler	76-81	4"	55900	55920
J10, J20 Pioneer 4WD	74-86	4"	55875	55920
Wagoneer 4WD Full Size	74-89	4"	55875	55920
Wrangler YJ	87-95	2"	55945	55900
Wrangler YJ	87-95	3.5-4.5"	55955	55950
Wrangler YJ	87-95	5-6"	55660*	55920
Wrangler TJ	97-06	0-1"	55960	55969
Wrangler TJ	97-06	2"	55979	55975
Wrangler TJ	97-06	3"	55965	55980
Wrangler TJ	97-06	4.5"	55967	55976
Wrangler TJ	97-06	6.5"	55962	55974
Wrangler JK	07-14	0"	55710	55980
Wrangler JK	07-14	2"	55710	55951
Wrangler JK	07-14	3"	55700	55951
Wrangler JK	07-14	4.5"	55700	55959
Wrangler JK	07-14	5.5"	55922	55958
Wrangler JK	07-14	6.5"	55952	55958
Cherokee XJ	84-01	0-2"	55979	55972
Cherokee XJ	84-01	3"	55965	55980
Cherokee XJ	84-01	4.5"	55965	55974
Cherokee XJ	84-01	6.5"	55961*	55920
Comanche MJ	86-92	2"	55960	55920
Comanche MJ	86-92	3"	55965	55920
Grand Cherokee ZJ	93-98	0-1"	55979	55900
Grand Cherokee ZJ	93-98	1.75-2"	55979	55950
Grand Cherokee ZJ	93-98	3"	55965	55950
Grand Cherokee ZJ	93-98	4.5"	55965	55920
Grand Cherokee ZJ	93-98	6.5"	55961*	55829
Grand Cherokee WJ	99-04	2"	55979	55970
Grand Cherokee WJ	99-04	4"	55978	55971
Grand Cherokee WK	05-08	4"	n/a	55977
Liberty KJ	02-07	2"	n/a	55968

* Stem eliminator kit #124015 required for installation

** Bar pin eliminator kit #124025 required for installation

SUZUKI & TOYOTA 4WD

Model	Year	Lift	Front Shock	Rear Shock
Suzuki Sidekick / Geo Tracker	88-98	4"	n/a	55800
Suzuki Samurai	85-95	4"	55800	55950
Toyota Tacoma 4WD	95.5-04	2.5"	n/a	55878
Toyota T-100	93-98	4"	55930	55939
Toyota Truck	86-95	4"	55930	55939
Toyota 4Runner	86-89	4"	55930	55939
Toyota FJ Cruiser	07-14	3"	n/a	55879
Toyota Tundra	07-14	0"	n/a	55700
Toyota Tundra	07-14	4"	n/a	55952
Toyota Tacoma	05-14	3"	n/a	55954
Toyota Tacoma	05-14	4"	n/a	55953



SHOCK BUSHING SETS

Part #	Description
079012.....	Std hourglass shock eye 5/8" I.D. (2 per set)
079022.....	Std hourglass shock eye 3/4" I.D. (2 per set)
079032.....	Lg hourglass shock eye 3/4" I.D. (2 per set)
079042.....	Std Stem bushing 3/8" I.D. (4 per set)
079052.....	Lg Stem Bushing 1/2" I.D. (4 per set)
079062.....	Lg Stem Bushing 3/8" I.D. (4 per set)
079072.....	Std O.D. tall stem bushing 10mm I.D. (4 per set)
079082.....	Lg O.D. tall stem bushing 14mm I.D. (4 per set)

Boots ordered separately

5500 SERIES SHOCK BOOTS

1-3/4" - 2"

Color	Retail (1/pkg)	Bulk
Red.....	098270	098275
Blue.....	098500	098505
Black.....	098520	098525

2-3/8"

Color	Retail (1/pkg)	Bulk
Red.....	099270	099275
Blue.....	099500	099505
Yellow.....	099510	099515
Black.....	099520	099525

Note: All packaged boots include shock ties



SPECIFICATIONS

SHOCK ABSORBERS

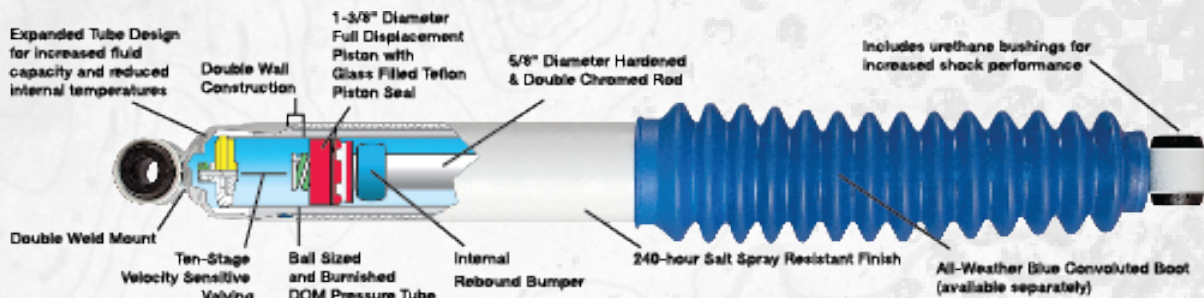

SHOCK ABSORBER SPECIFICATIONS

Part #	Raw Cylinder	Extended Length	Collapsed Length	Body Diameter	Top Mount	Bottom Mount
55600	5263	24.84	14.82	2"	EB1-B	EB1-C
55601	5244	19.50	13.17	2"	EB1-B	EB1-C
55602	5240	21.50	13.75	2-3/8"	S1	Special U Brkt.
55603	5244	19.50	13.17	2"	EB1-B	EB1-B
55604	5276	21.32	14.64	2"	S1	EB1-A
55605	5241	22.18	13.37	2"	S50	EB1-C
55606	5241	22.18	13.37	2"	S50	EB1-D
55608	5251	26.20	15.80	2-3/8"	BP8	EB1-D
55609	5550	30.95	18.17	2-3/8"	BP8	EB1-A
55610	5245	22.95	14.67	2"	EB1-B	EB1-B
55612	5239	16.57	10.99	2-3/8"	S1	Special U Brkt.
55619	5251	25.95	15.42	2"	EB1-B	EB1-B
55620	5247	23.12	14.25	2-3/8"	EB1-A	EB1-A
55628	5251	26.20	15.80	2-3/8"	EB1-A	EB1-A
55629	5251	26.20	15.80	2-3/8"	EB1-A	EB1-D
55639	5248	29.78	17.59	2-3/8"	EB1-A	EB1-D
55650	5251	26.20	15.80	2-3/8"	EB1-A	EB1-A
55651	5250	27.91	16.55	2-3/8"	EB1-A	EB1-A
55660	5248	29.78	17.59	2-3/8"	EB1-A	EB1-A
55662	5248	29.78	17.59	2-3/8"	BP8	EB1-B
55700	5345	25.22	15.22	2-3/8"	S50	EB2
55710	5340	22.50	13.50	2-3/8"	S50	EB2
55711	5276	21.32	14.64	2"	S1	EB1-D
55719	5251	26.20	15.80	2-3/8"	EB1-D	EB1-D
55750	5371	27.40	16.22	2-3/8"	S50	EB2
55751	5372	30.00	17.24	2-3/8"	S50	EB2
55752	5373	27.45	16.17	2-3/8"	S50	EB2
55756	5250	27.91	16.55	2-3/8"	Special	EB1-D
55758	5250	27.91	16.55	2-3/8"	EB1-D	EB1-D
55759	5248	29.78	17.59	2-3/8"	EB1-D	EB1-D
55760	5249	33.00	19.27	2-3/8"	EB1-B	EB1-B
55761	5249	33.00	19.27	2-3/8"	EB1-D	EB1-D
55762	5249	33.00	19.27	2-3/8"	BP8	EB1-B
55765	5252	35.50	20.40	2-3/8"	EB1-B	EB1-B
55766	5252	35.50	20.42	2-3/8"	BP8	EB1-B
55769	5550	30.95	18.17	2-3/8"	EB1-D	EB1-D
55800	5346	20.42	12.67	2-3/8"	S1	EB1-A
55804	5241	22.18	13.37	2"	S50	EB1-D
55805	5343	14.75	9.57	2-3/8"	S1	EB1-A
55810	5347	16.91	10.91	2-3/8"	S1	EB1-A
55819	5361	26.42	15.39	2"	S1	EB1-C
55820	5349	22.92	13.92	2-3/8"	S1	EB1-A
55829	5248	29.78	17.59	2-3/8"	EB1-A	EB1-A
55850	5325	26.17	15.55	2-3/8"	S1	EB1-A
55860	5350	29.82	17.57	2-3/8"	S1	EB1-A
55875	5247	23.12	14.25	2-3/8"	EB1-A	EB1-A
55877	5550	30.95	18.17	2-3/8"	EB1-A	EB1-A
55878	5262	22.95	14.67	2"	EB1-C	EB1-C
55879	5345	25.22	15.22	2-3/8"	S50	EB2
55900	5243	21.70	13.42	2"	EB1-A	EB1-A
55920	5266	25.95	15.42	2"	EB1-A	EB1-A
55922	5371	27.40	16.22	2-3/8"	S50	EB2
55930	5346	20.42	12.67	2-3/8"	S1	EB1-A
55939	5251	26.20	15.80	2-3/8"	EB1-C	EB1-C

* Also available in 9500 Series

SHOCK ABSORBER SPECIFICATIONS

Part #	Raw Cylinder	Extended Length	Collapsed Length	Body Diameter	Top Mount	Bottom Mount
55945	5361	26.42	15.39	2"	S1	EB1-B
55950	5262	22.95	14.67	2"	EB1-A	EB1-B
55951	5266	25.95	15.42	2"	BP18	EB1-B
55952	5372	30.00	17.24	2-3/8"	S50	EB2
55953	5350	29.82	17.57	2-3/8"	S1	EB1-A
55955	5362	28.16	16.43	2"	S1	EB1-B
55958	5248	29.78	17.59	2-3/8"	BP18	EB1-B
55959	5250	28.00	16.50	2-3/8"	BP18	EB1-A
55960	5346	20.42	12.67	2-3/8"	S1	BP7
55961	5251	26.20	15.80	2-3/8"	EB1-A	EB1-A
55962	5350	29.82	17.57	2-3/8"	S1	BP7
55965	5348	24.90	14.81	2-3/8"	S1	BP7
55967	5325	26.17	15.55	2-3/8"	S1	BP7
55968	5247	23.12	14.25	2-3/8"	EB1-B	EB1-B
55969	5244	19.50	13.17	2"	BP18	EB1-A
55970	5262	22.95	14.67	2"	EB1-A	EB1-A
55971	5251	26.20	15.80	2-3/8"	EB1-A	EB1-A
55972	5243	21.70	13.42	2"	BP18	EB1-A
55974	5266	25.95	15.42	2"	BP18	EB1-A
55976	5247	23.12	14.25	2-3/8"	BP18	EB1-A
55977	5248	29.80	17.59	2-3/8"	EB1-C	EB1-C
55978	5348	24.68	14.81	2-3/8"	S1	EB1-A
55979	5349	22.92	13.92	2-3/8"	S1	BP7-A
55980	5262	22.95	14.67	2"	BP18	EB1-A

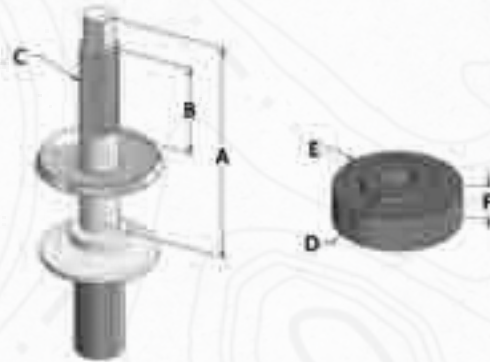
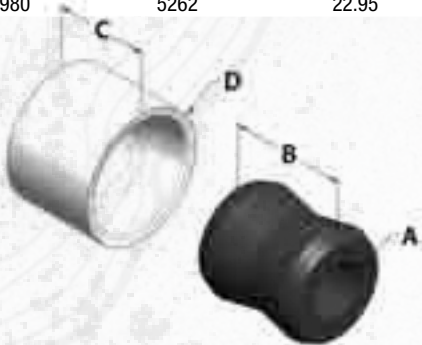

"EB" Eyelet Bushing Mounting Dimensions

Code	A	B	C	D (Dia)
EB1-A	5/8"	1-7/16"	15/16"	1-7/16"
EB1-B	5/8"	1-1/2"	15/16"	1-7/16"
EB1-C	3/4"	1-7/16"	15/16"	1-7/16"
EB1-D	3/4"	1-5/8"	15/16"	1-7/16"
EB1-E	5/8"	1-1/4"	15/16"	1-7/16"
EB2	3/4"	1-5/8"	1-1/4"	1-3/4"

"S" Stem Bushing Mounting Dimensions

Code	A	B	C	D	E	F
S1	2-3/8"	1-1/8"	3/8"-24	3/4"	1-1/4"	1/2"
S50	3"	1-1/4"	1/2"-20	15/16"	1-5/8"	9/16"

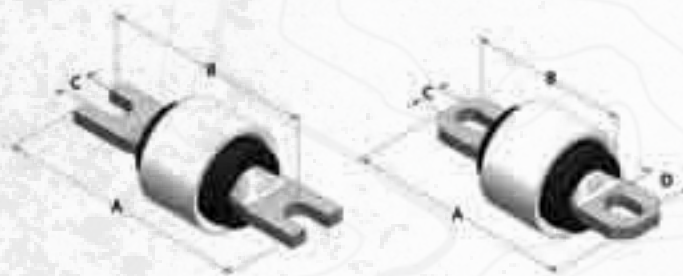

"BP" Bar Pin Mounting Dimensions EB1 with bushing and bar pin

Code	Style	A	B	C	D
BP7	Closed	3-1/4"	2-1/2"	3/8"	7/16"
BP8	Closed	3-1/2"	2-7/8"	3/8"	7/16"
BP18	Open	3-3/4"	3-1/8"	3/8"	-

CHEVROLET/ GMC

STEERING STABILIZER MOUNTING SYSTEMS



Features Include:

- Heavy-duty gusseted construction
- Yellow zinc plating for long life
- All hardware and instructions included
- Single and dual systems available for most lifted applications

Installation of Complete System Will...

- Enhance vehicle control with reduced steering shimmy and bumpsteer
- Improve tire wear and front-end component life
- Lessen side-to-side motion caused by wide tires and road conditions

CHEVROLET/GMC 4WD

Model	Year	Single		Dual		Notes
		Cylinder	Bracket Kit	Cylinder*	Bracket Kit	
Truck Silverado/Sierra 1/2 Ton	99-06	55402	55327			
Truck Silverado/Sierra 1/2 Ton	99-06			55410	55354	3,7
Truck K2500 HD 2WD & 4WD	11-14	55425				
Truck K2500 HD – OE Replacement	01-10	55411				
Truck K2500 HD 2WD & 4WD	01-10			55423	55363	3,7
Suburban, Avalanche 2500	01-06	55411				
Suburban, Avalanche 2500	01-06			55423	55363	3,7
Truck K1500, K2500 – w/ OE Stabilizer	88-98	55401	55328			
Truck K1500, K2500 – w/o OE Stabilizer	88-98	55401	55326			9
Truck K1500, K2500	88-98			55410	55362	1,2
Truck 1/2, 3/4, 1 ton – OE Replacement	73-87	55404		55402	55361	2,6,8
Truck 1/2, 3/4, 1 ton – w/o OE Stabilizer	73-87	55402	55310	55404	55351	3,6,8
Truck 1/2, 3/4, 1 ton – w/ 3" diameter axle tube	69-72	55402	55310			
Truck S-Series & ZR2	95-04	55414				4
Truck S-Series & ZR2 – OE Replacement	83-04	55401				
Truck S-Series – w/o OE Stabilizer	83-97	55401	55326			9
Tahoe, Yukon, Suburban 1500	00-06	55402	55327			
Tahoe, Yukon, Suburban 1500	00-06			55410	55354	3,7
Tahoe, Yukon, Suburban – w/ OE Stabilizer	92-98	55401	55328			
Tahoe, Yukon, Suburban – w/o OE Stabilizer	92-98	55401	55326			9
Tahoe, Yukon, Suburban	92-98			55410	55362	1,3
Blazer, Jimmy, Suburban – Stacked	69-91	55404		55402	55361	2,6,8
Blazer, Jimmy, Suburban – End-to-End	69-91	55402	55310	55404	55351	3,6,8
Blazer, Jimmy S-Models & ZR2	95-04	55414				4
Blazer, Jimmy S-Models & ZR2 – OE Replacement	83-94	55401				
Blazer, Jimmy S-Models – w/o OE Stabilizer	83-94	55401	55326			9

DODGE 4WD

Model	Year	Single		Dual		Notes
		Cylinder	Bracket Kit	Cylinder*	Bracket Kit	
Truck Ram 1500	06-12	55419	55311	55419	55311	11
Truck Ram 1500 - Mega Cab - Y-Style Steering	06-08	55424		55416	55357	3,8
Truck Ram 1500	02-05	55419	55311	55419	55311	11
Truck Ram 1500 – OE Replacement	2001	55406		55404	55351	3,6,8
Truck Ram 1500 – OE Replacement	94-00	55417		55404	55351	3,6,8
Truck Ram 2500 – OE Replacement	94-00	55417		55404	55351	3,6,8
Truck Ram 2500, 3500	01-02	55406		55404	55351	3,6,8
Truck Ram 2500, 3500 - Y-Style Steering	03-08	55424		55416	55357	3,8
Truck Ram 2500, 3500-T-Style Steering – OE Replacement	09-12	55422		55422	55369	
Truck Ram 2500, 3500 OE Radius Arm Trucks	13-14	55427		55422	55370	
Ramcharger, Trailduster	60-93	55403	55310	55402	55361	2,6,8
Truck 1/2, 3/4, 1 Ton	60-93	55403	55310	55402	55361	2,6,8

FORD 4WD

Model	Year	Single		Dual		Notes
		Cylinder	Bracket Kit	Cylinder*	Bracket Kit	
Ranger	83-97	55402	55337	55402	55324	2,8,10
Bronco II	83-90	55402	55337	55402	55324	2,8,10
F-150 4WD	97-03	55412				7
Expedition	98-02	55412				7
F150 4WD w/ BDS Replacement Strut Kits	04-08	55402	55338	55402	55339	11
F150 4WD w/ BDS Strut Spacer Kits	04-08	55402	55312	55402	55367	11
F-150 – Excluding Quad Shocks	80-96	55402	55337	55402	55325	2,8
F-150 – w/ Quad Shocks	80-96	55402	55306	55402	55365	3,8
F-100, F-150 – OE Replacement	70-79	55403				
F-100, F-150 – w/o anti-sway bar	70-79			55402	55361	2,5,8
Explorer	90-94	55402	55337			
Bronco – Excluding Quad Shocks	80-96	55402	55337	55402	55325	2,8
Bronco – w/ Quad Shocks	80-96	55402	55306	55402	55365	3,8
Bronco – OE Replacement	70-79	55403				
Bronco – w/o anti-sway bar	78-79			55402	55361	2,8
Bronco – OE Replacement	66-69	55404				
F-250, F-350 Super Duty,	05-07	55415	55309	55405	55358	3, 12
F-250, F-350 Super Duty,	08-14	55415	55368	55405	55358	
F-250, F-350 Super Duty, Excursion - OE Replacement	99-04	55405		55408	55364	3,8
F-250, F-350 – Excluding Monobeam F350	80-96	55402	55337			
F-350 – w/ Monobeam	86-96	55402	55310	55404	55351	3,8

Boots ordered separately

JEEP

Model	Year	Single		Dual		Notes
		Cylinder	Bracket Kit	Cylinder*	Bracket Kit	
Wrangler JK	07-14	55421				14
Wrangler JK	07-14	55401		55405	55366	13
Wrangler TJ – OE Replacement	97-06	55407		55408	55356	3,8
Wrangler YJ – OE Replacement	87-96	55407		55402	55353	2,8
CJ5, CJ7, CJ8 – OE Replacement	76-86	55410				
CJ2A, CJ3A, CJ3B, CJ5, CJ6, CJ7, CJ8	42-86	55402	55307**			
MB, M38, M38A1	41-75	55402	55307**			
Grand Cherokee ZJ – OE Replacement	93-98	55401		55408	55356	
Grand Cherokee WJ – OE Replacement	99-04	55409		55426	55366	3
Cherokee Mid Size XJ – OE Replacement	84-01	55401		55408	55356	
Comanche MJ – OE Replacement	86-92	55401				
Truck, Cherokee, Wagoneer – OE Replacement	74-91	55404				

SUZUKI

Model	Year	Single		Dual		Notes
		Cylinder	Bracket Kit	Cylinder*	Bracket Kit	
Samurai	85-95	55403	55307			

* When ordering dual stabilizer kit, you must order two (2) cylinders and one (1) bracket kit.

** Will not fit with factory sway bar

Boots ordered separately

Notes

1. Dual stabilizer kit only works in combination with the 6" BDS suspension system.
2. Dual stabilizer kit is a stacked design (over/under).
3. Dual stabilizer kit is an end-to-end design.
4. 55414 stabilizer kit only works in combination with the 5" BDS suspension system.
5. 1976-77 models with power steering and inverted "Y" steering linkage must be converted to a 1978-79 inverted "T" style in order to install dual steering stabilizers.
6. For 3-1/4" axle tube diameter only.
7. Will not work with suspension lifts that use a modified steering link and will not fit stock height vehicles.
8. Dual stabilizer kit will work on stock height applications.
9. Single bracket kit 55326 will work on stock height only.
10. Will not work with vehicles equipped with factory front sway bar.
11. Single and dual kits will only work in combination with the 4"-6" BDS Suspension systems.
12. Dual system will not work for vehicles with 2" of lift or less.
13. For use with BDS kits 4" of lift or higher.
14. For use with 3" of lift or less.

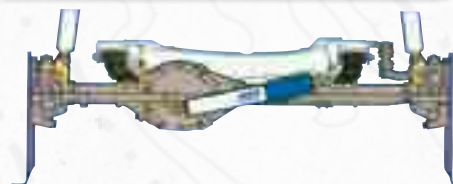

SPECIFICATIONS

STEERING STABILIZER

STEERING STABILIZER SPECIFICATIONS

Part #	Cylinder	Extended	Collapsed	Cylinder Diameter	Body Mount	Rod Mount	Available in 9500
55401	5623	19.26	12.17	2"	EB1-A	EB1-A	
55402	5402	20.11	11.86	2-3/8"	S1	S1	
55403	5622	22.36	12.99	2"	S1	S1	
55404	5621	23.92	14.30	2"	EB1-A	EB1-A	X
55405	5621	23.92	14.30	2"	EB1-A	EB1-A	X
55406	5621	23.92	14.30	2"	EB1-A	EB1-A	X
55407	5624	19.75	12.13	1-3/4"	EB1-A	EB1-A	X
55408	5621	23.92	14.30	2"	EB1-A	EB1-A	X
55409	5624	19.75	12.13	1-3/4"	EB1-A	EB1-A	X
55410	5620	17.06	10.48	1-3/4"	S1	EB1-A	
55411	5623	19.26	12.17	2"	EB1-A	EB1-A	
55412	5623	19.26	12.17	2"	EB1-A	EB1-A	
55414	5620	17.06	10.48	1-3/4"	S1	EB1-A	
55415	5621	23.92	14.30	2"	EB1-A	EB1-A	X
55416	5621	23.92	14.30	2"	EB1-A	EB1-A	X
55417	5621	23.92	14.30	2"	EB1-A	EB1-A	X
55419	5623	19.26	12.17	2"	EB1-A	EB1-A	
55420	5623	19.26	12.17	2"	EB1-A	EB1-A	
55421	5623	19.26	12.17	2"	EB1-A	EB1-A	X
55422	5621	23.92	14.3	2"	EB1-A	EB1-A	X
55423	5624	19.75	12.13	1-3/4"	EB1-A	EB1-A	
55424	5621	23.92	14.30	2"	EB1-A	EB1-A	X
55425	5621	23.92	14.30	2"	EB1-A	EB1-A	X
55426	5624	19.75	12.13	1-3/4"	EB1-A	EB1-A	X
55427	5621	23.92	14.3	2"	EB1-A	EB1-B	X

9500 SERIES STEERING STABILIZER MOUNTING SYSTEMS

DODGE

FORD

JEEP

SUZUKI

TOYOTA

POSI-LOK

SHOCKS/
STEERING
STABILIZERS

APPAREL/
PROMOTIONAL

PRODUCT
SPECS

VEHICLE
SPECS

Features Include:

- Hydraulic stabilizer cylinders with a brushed stainless appearance and a top clear coat
- Heavy-duty gusseted mounting brackets
- All hardware and instructions included

Installation of Complete System Will...

- Enhance vehicle control with reduced steering shimmy and bump steer
- Improve tire wear and front-end component life
- Lessen side-to-side motion caused by wide tires and road conditions



DODGE 4WD

Model	Year	Single		Dual		Notes
		Cylinder	Bracket Kit	Cylinder*	Bracket Kit	
Truck Ram 1500 – Mega Cab	06-08	95406		95405	55357	1,3
Truck Ram 1500 – OE Replacement	2001	95406		95404	55351	1,2,3
Truck Ram 1500 – OE Replacement	94-00	95417		95404	55351	1,2,3
Truck Ram 2500 – OE Replacement	94-00	95417		95404	55351	1,2,3
Truck Ram 2500, 3500	01-02	95406		95404	55351	1,2,3
Truck Ram 2500, 3500	03-08	95424		95416	55357	1,3,5
Truck Ram 2500, 3500 – OE Replacement	09-12	95422		95422	55369	1,5
Truck Ram 2500, 3500 OE Radius Arm Trucks	13-14	95427		95422	55370	1

FORD 4WD

Model	Year	Single		Dual		Notes
		Cylinder	Bracket Kit	Cylinder*	Bracket Kit	
F-250, F-350 Super Duty,	05-14	95415	55309	95405	55358	1
F-250, F-350 Super Duty, Excursion	99-04	95405		95408	55364	1,3
F-350 – w/ Monobeam	86-96			95404	55351	1,3

JEEP 4WD

Model	Year	Single		Dual		Notes
		Cylinder	Bracket Kit	Cylinder*	Bracket Kit	
Wrangler JK	07-14	95421		95405	55366	1,4
Wrangler TJ, XJ, ZJ – OE Replacement	97-06	95407		95408	55356	1,3
Wrangler YJ	87-96	95407				
Grand Cherokee WJ – OE Replacement	99-04	95409		95426	55366	1,3

* When ordering dual stabilizer kit, you must order two (2) cylinders and one (1) bracket kit.
Notes

1. Dual stabilizer kit is an end-to-end design.
2. For 3-1/4" axle tube diameter only. Does not fit Dana 60 front axle.
3. Dual stabilizer kit will work on stock height applications.
4. Dual system work with BDS 4" of lift or higher.
5. 55357 bracket kit is designed for trucks with Y-style steering. 55369 bracket kit is designed for trucks with T-style steering.

Boots ordered separately



FOX 2.0 PERFORMANCE SERIES STEERING STABILIZERS



DODGE 4WD

Model	Year	Single		Dual		Notes
		Cylinder	Bracket Kit	Cylinder*	Bracket Kit	
Truck Ram 2500	2014	98224018		98224016	55370	1
Truck Ram 3500	13-14	98224018		98224016	55370	1

* When ordering dual stabilizer kit, you must order two (2) cylinders and one (1) bracket kit.
Notes

1. Dual stabilizer kit is an end-to-end design.

Boots ordered separately

ADD-A-LEAF & U-BOLT

APPLICATION CHART

CHEVROLET/
GMC

DODGE

FORD

JEEP

SUZUKI

TOYOTA

POSI-LOK

SHOCKS/
STEERING
STABILIZERS

APPAREL/
PROMOTIONAL

PRODUCT
SPECS

VEHICLE
SPECS

CHEVROLET/GMC

Model	Year	Long	Front U-Bolts	Qty	Rear Short	Long	U-Bolts	Qty
K5 Blazer, Jimmy 4WD	77-91	119151	4020	3	119158	119157	4020	4
			4032	1				
K5 Blazer, Jimmy 4WD	73-76	119151	4018	3	119158	119157	4020	4
			4032	1				
Truck 1/2 Ton 2WD	99-14	NA	NA	NA		111209	4036	4
Truck 1/2 Ton 2WD	88-98	NA	NA	NA		119157	4036	4
Truck 1/2 Ton 2WD	73-87	NA	NA	NA	119158	119157		
Truck 1/2 Ton 4WD	99-14	NA	NA	NA		111209	4036	4
Truck 1/2 Ton 4WD-6 Lug	88-98	NA	NA	NA		119157	4036	4
Truck 1/2 Ton 4WD	77-87	119151	4020	3	119158	119157	4020	4
			4032	1				
Truck 1/2 Ton 4WD	73-76	119151	4018	3	119158	119157	4020	4
			4032	1				
Truck 3/4 Ton 2WD	88-98	NA	NA	NA		119157	4036	4
Truck 3/4 Ton 2WD	73-87	NA	NA	NA	119158	119157		
Truck 3/4 Ton 4WD	01-10	NA	NA	NA		119157	4036	4
Truck 3/4 Ton 4WD-6 Lug	88-98	NA	NA	NA		119157	4036	4
Truck 3/4 Ton 4WD	77-87	119151	4020	3	119158	119157	4032	4
			4032	1				
Truck 3/4 Ton 4WD	73-76	119151	4018	3	119158	119157	4032	4
			4032	1				
Suburban 4WD 1/2, 3/4 Ton-6 Lug	92-99	NA	NA	NA		119157	4036	4
Suburban 4WD 1/2 Ton	77-87	119151	4020	3	119158	119157	4020	4
			4032	1				
Suburban 4WD 1/2 Ton	73-76	119151	4018	3	119158	119157	4020	4
			4032	1				
Suburban 4WD 3/4 Ton	77-91	119151	4020	3	119158	119157	4032	4
			4032	1				
Suburban 4WD 3/4 Ton	73-76	119151	4018	3	119158	119157	4032	4
			4032	1				
Colorado/Canyon 4WD	04-12	NA	NA	NA		114208	4016	4
S10, S15 Truck / Blazer 4WD	82-05	NA	NA	NA		119157*	4005	4
Van G10, G20, G30 2WD	71-95	NA	NA	NA	119158			

DODGE

Model	Year	Long	Front U-Bolts	Qty	Rear Short	Long	U-Bolts	Qty
Dakota 4WD	87-96	NA	NA	NA	119159			
D50 2WD, 4WD	79-91	NA	NA	NA	119159			
Truck 1/2 Ton 2WD/4WD	94-01	NA	NA	NA		119157*	4045	4
Truck 1/2 Ton 2WD	61-93	NA	NA	NA	119158			
Truck 1/2 Ton 4WD	61-93	119151	4047	2	119158		4045	4
			4055	1				
			122001	1				
Truck 3/4 Ton 2WD	61-93	NA	NA	NA	119158			
Truck 3/4 Ton HD 4WD 3" wide	94-02	NA	NA	NA		113208(S)	4049**	4
						or 113209(D)		
Truck 3/4 Ton 4WD 2.5" wide	69-74	119151	4036	4	119158		4045	4
Raider 4WD	86-93				119159			
Ramcharger, Trailduster 4WD	74.5-93	119151	4047	2	119158		4045	4
			4055	1				
			122001	1				
Ramcharger, Trailduster 4WD	69-74	119151			119158	119157	4045	4

* May need to be trimmed to fit properly.

Note:

Add-A-Leaf kits come with center bolts and alignment clamps, order one kit per axle. (S)-Single (D)-Dual **w/o top mounted overload. BDS Add-A-Leaf kits generally give between 1" and 3" of lift, depending on the specific application.

ADD-A-LEAF & U-BOLT

APPLICATION CHART

DODGE

FORD

JEEP

SUZUKI

TOYOTA

POSI-LOK

SHOCKS/
STEERING
STABILIZERS

APPAREL/
PROMOTIONAL

PRODUCT
SPECS

VEHICLE
SPECS

FORD

Model	Year	Long	Front U-Bolts	Qty	Rear Short	Long	U-Bolts	Qty
Bronco 4WD 3" wide rr. spr.	78-96	NA	NA	NA		113208 (S) or 113209 (D)	4051	4
Bronco 4WD	66-77	NA	NA	NA	119158		4057	4
Bronco II	82-91	NA	NA	NA	119159	114202	4005	4
F-150 4WD	04-08	NA	NA	NA		113219	4053*	4
F-150 4WD	97-03	NA	NA	NA		113207	4051	4
F-100, F-150 2WD 2.5" wide	62-96	NA	NA	NA	119158		4051	4
F-100, F-150 4WD 3" wide	70-96	NA	NA	NA		113208 (S) or 113209 (D)	4051	4
F-250, F-350 Super Duty	05-07	NA	NA	NA		113218	4033	4
F-250, F-350 Super Duty	99-04	113201	4053 or 4046*	4		113206 (S) or 113209 (D)	4034**	4
F-250 2WD	57-79	NA	NA	NA	119158			
F-250, F-350 4WD 3" wide rr. spr.	78-97	113201	4053*			113206 (S) or 113209 (D)	4033	4
Ranger 2WD-Except composite spring	82-97	NA	NA	NA	119159		4007	4
Ranger 4WD	98-02	NA	NA	NA		113207		
Ranger 4WD	83-97	NA	NA	NA	119159	114202	4007	4
Van E-Series	65-91	NA	NA	NA	119158			4

(S) - Single (D) - Dual

*4053 square u-bolts - 4046 has rounded corners - must check vehicle before ordering.

**With 3-5/8 diameter rear axle and w/o top overload. See U-bolt page for additional listings.

JEEP

Model	Year	Long	Front U-Bolts	Qty	Rear Short	Long	U-Bolts	Qty
CJ5, CJ7	76-86	114201	4001 4012	3 1		114209	4001	4
Wrangler YJ	87-95	114202	4001 4016	2 2		114202	4001	4
Cherokee XJ	84-01	NA	NA	NA		114202		
Gladiator	63-91				119158			
Truck J-Series, Wagoneer	74-90	119151	4054 4047	2 2	119158		4048	4

TOYOTA

Model	Year	Long	Front U-Bolts	Qty	Rear Short	Long	U-Bolts	Qty
Land Cruiser	55-84	114202	4057 4058	3 1		114202	4057	4
Truck 4WD 2.5" rr. spr.	86-96				119159		4039	4
Truck 4WD 2.5" rr. spr.	79-85				119159		4039	4
4Runner 4WD 2.5" rr. spr.	86-89				119159		4039	4
4Runner	79-85				119159		4039	4

INTERNATIONAL, ISUZU, MITSUBISHI, NISSAN

Model	Year	Long	Front U-Bolts	Qty	Rear Short	Long	U-Bolts	Qty
International Truck, Travelall	60-75	119151			119158			
Isuzu Truck 2WD, 4WD	81-95				119159			
Mitsubishi Truck 2WD, 4WD	82-84				119159			
Mitsubishi Montero 4WD	86-91				119159			
Nissan Truck 2WD, 4WD	68-96				119159			

Note:

U-bolts listed may be longer than necessary for Add-A-Leaf installation. U-bolt sizes were based on maximum OE leaf packs which can vary widely due to towing packages, GVWR variations, etc. BDS Add-A-Leaf kits generally give between 1" and 3" of lift, depending on the specific application.

LEAF SPRING EYE BOLT KITS

Application	Year	Front Part #	Rear Part #	Both Front & Rear	Notes
Chevy Blazer, Jimmy, Suburban	73-87	121004	121009		1
Chevy 1/2, 3/4 Ton Truck	73-87	121004	121009		1
Chevy Blazer, Jimmy, Suburban	88-91	121005	121009		1
Jeep Wrangler YJ	87-95			124008	2
Jeep J10, 20 FS Wagoneer/Cherokee	74-90	121009	121009		1

All bolt kits come with Grade 8 bolts, thru-hardened washers, and prevailing torque nuts. All fasteners are yellow zinc plated.

Notes

- Kit includes 4 spring eye bolts with nuts and washers.
- Kit includes 8 spring eye bolts with nuts and washers.

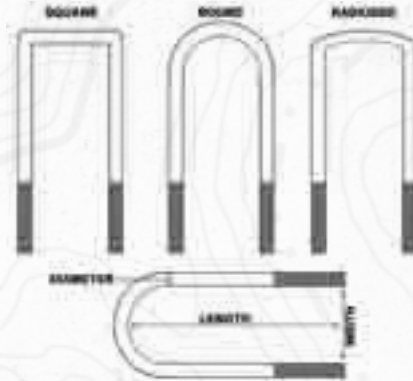

INDIVIDUAL U-BOLTS

Part #	Diameter	Width	Length	Shape
UBT4001	1/2"	2-1/2"	6-3/4"	Round
UBT4004	1/2"	2-3/4"	5-1/2"	Round
UBT4005	1/2"	2-3/4"	6-1/2"	Round
UBT4007	1/2"	2-3/4"	8-1/2"	Round
UBT4009	1/2"	2-3/4"	11"	Round
UBT4010	1/2"	2-3/4"	12-1/2"	Round
UBT4011	1/2"	2-3/4"	14"	Round
UBT4012	1/2"	3"	6-3/4"	Round
UBT4013	1/2"	3"	8-1/2"	Round
UBT4015	1/2"	3"	11-1/2"	Round
UBT4016	1/2"	3-1/4"	7"	Round
UBT4017	1/2"	3-1/2"	4-1/2"	Round
UBT4018	5/8"	2-3/4"	8"	Round
UBT4019	5/8"	2-9/16"	12"	Square
UBT4020	5/8"	3"	8"	Round
UBT4021	5/8"	3"	10"	Round
UBT4022	5/8"	3"	12"	Round
UBT4024	5/8"	3"	14-1/2"	Round
UBT4025	9/16"	3-1/2"	10-1/2"	Round
UBT4026	5/8"	3-1/2"	14-1/2"	Round
UBT4032	5/8"	3-5/8"	10"	Round
UBT4033	5/8"	3-5/8"	12"	Round
UBT4034	5/8"	3-5/8"	15"	Round
UBT4035	5/8"	3-5/8"	18-1/2"	Round
UBT4036	9/16"	2-1/2"	8-3/4"	Square
UBT4037	9/16"	2-1/2"	10"	Square
UBT4038	9/16"	2-1/2"	14"	Square
UBT4039	9/16"	2-1/2"	7"	Square
UBT4040	9/16"	2-1/2"	7"	Round
UBT4041	9/16"	2-3/4"	7"	Round
UBT4042	9/16"	2-9/16"	15"	Square
UBT4043	9/16"	3-1/8"	10-1/2"	Square
UBT4044	9/16"	3-1/8"	11"	Radius
UBT4045	9/16"	2-9/16"	11-3/8"	Square
UBT4046	9/16"	3-1/8"	9-1/2"	Radius
UBT4047	9/16"	3"	7-1/2"	Round
UBT4048	9/16"	3"	9-1/2"	Round

Part #	Diameter	Width	Length	Shape
UBT4049	9/16"	3-1/8"	15"	Square
UBT4050	9/16"	3-1/8"	18"	Square
UBT4051	9/16"	3-1/4"	10"	Round
UBT4052	9/16"	3-1/4"	14"	Round
UBT4053	9/16"	3-1/8"	9"	Square
UBT4054	9/16"	3-1/2"	9-1/2"	Round
UBT4055	9/16"	3-3/4"	9-5/8"	Round
UBT4056	9/16"	3-5/16"	14-3/4"	Round
UBT4059	9/16"	3-1/4"	12-1/2"	Round
UBT4060	9/16"	3"	11"	Round
UBT4061	9/16"	3-1/4"	10"	Square
UBT4062	9/16"	4"	12-1/2"	Round
UBT4063	9/16"	4"	14-1/2"	Round
UBT4064	9/16"	3-1/2"	12-1/2"	Round
UBT4065	9/16"	3-1/2"	14-1/2"	Round
UBT4067	9/16"	4"	12-1/2"	Round
UBT4068	9/16"	4"	16-1/4"	Round
UBT4075	3/8"	2-3/4"	3-3/4"	Round
UBT4079	3/8"	3-1/2"	4-3/4"	Round
UBT4080	3/8"	3-1/4"	3-3/4"	Round
UBT4081	3/8"	3"	4"	Round
UBT4082	5/16"	1-1/4"	2"	Round
UBT4083	5/16"	1-1/2"	2-1/4"	Round
UBT4084	7/16"	4-1/4"	4-3/4"	Square
UBT4085	7/16"	4-1/4"	4-3/4"	Round
UBT4086	5/16"	1"	1-3/4"	Round
UBT4087	5/16"	3/4"	1-3/8"	Round
UBT4090	7/16"	6-1/4"	4-1/8"	Square
UBT4091	7/16"	7-5/8"	4-1/8"	Square
UBT4144	9/16"	3-1/8"	12-1/2"	Square
UBT4145	9/16"	2-9/16"	12-1/2"	Square
UBT4230	3/4"	3-1/4"	13-1/2"	Square
UBT4231	3/4"	3-1/4"	15-1/2"	Square
UBT4234	3/4"	3-5/8"	15"	Round
UBT4235	3/4"	3-5/8"	18-1/2"	Round
UBT4268	3/4"	4"	16"	Round
UBT4269	3/4"	4"	18-1/2"	Round

Notes

- All 1/2", 9/16", and 5/8" u-bolts come with high nuts and washers. All 5/16", 3/8", and 7/16" u-bolts come with prevailing torque nuts and washers.

DODGE

FORD

JEEP

SUZUKI

TOYOTA

POSI-LOK

SHOCKS/
STEERING
STABILIZERS

APPAREL/
PROMOTIONAL

PRODUCT
SPECS

VEHICLE
SPECS

STEERING/PITMAN ARMS

Application	Year	Description	Part#	Height	Notes
CHEVROLET					
Blazer, Jimmy, Suburban	73-91	Steering Arm	081401	5"	
Blazer, Jimmy, Suburban	73-91	Adjustable Drag Link	081402		1
GM Truck 1/2, 3/4 Ton	73-87	Steering Arm	081401	5"	
GM Truck 1/2, 3/4 Ton	73-87	Adjustable Drag Link	081402		1
GM Truck 1/2, 3/4 Ton	73-87	3" Steering Block	082501		2,5
DODGE					
Dodge 2500, 3500	09-14	Pitman Arm	082404	5-1/4"	
Dodge 2500, 3500	03-08	Pitman Arm	082403	5"	
Dodge Full Size (PS)	00-02	Pitman Arm	082402	5"	
Dodge Full Size (PS)	94-99	Pitman Arm	082401	5"	
Dodge 3" Steering Block	69-93	3" Steering Block	082501		2,5
FORD					
F-250, 350 Super Duty	05-14	Pitman Arm	083404	5-1/8"	
F-250, 350 Super Duty	99-04	Pitman Arm	083403	4-1/2"	3
Ranger (PS)	83-97	Pitman Arm	083401	4"	
Bronco (PS)	80-96	Pitman Arm	083401	4"	
F-100, F-150, F-250 (PS)	80-96	Pitman Arm	083401	4"	
F-100, F-150, Bronco (PS)	78-79	Pitman Arm	083402	4"	
JEEP					
Wrangler JK	07-14	Pitman Arm	084402	4-7/8"	
Wrangler YJ, TJ (PS)	87-06	Pitman Arm	084404	4-1/2"	
Cherokee XJ	84-01	Pitman Arm - Extreme Drop	084601	6-7/8"	
Grand Cherokee WJ	99-04	Pitman Arm	084403	4-1/2"	
Grand Cherokee ZJ	93-98	Pitman Arm - Extreme Drop	084601	6-7/8"	
J10, J20, Cherokee	74-90	Pitman Arm	083402	4"	4
CJ5, CJ7 (PS)	76-86	Pitman Arm	084401	4-1/4"	
IMPORTS					
Suzuki Samurai	85-95	Pitman Arm	087401	4-1/4"	

TRACK BAR RELOCATION KITS

Application	Year	Part#	Lift
DODGE			
Dodge 1/2 & 3/4 Ton	94-01	122502	5"
Dodge 1/2 & 3/4 Ton	94-02	122311	3"
Dodge 3/4 Ton	03-07	122312	3"
Dodge 3/4 Ton	03-07	122601	6"
Dodge 3/4 Ton	08-13	122313	3"
Dodge 3/4 Ton	08-13	122621	6"
FORD			
Ford F-100/150 4WD	73-79	123001	4",6"
Ford F-250/350	08-13	123412	4",6"
Ford F-250/350	08-13	123802	8"
Ford F-250/350	05-07	123010	4",6"
Ford F-250/350	05-07	123801	8"
Ford F-250/350	3-1-99 to 04	123201	2"
Ford F-350**	86-97	123407	4"
Ford Super Duty	3-1-99 to 04	123250	2.5"
Ford Super Duty	3-1-99 to 04	123405	4"
Ford Super Duty	3-1-99 to 04	123602	6",8"
Ford Super Duty	up to 2-28-99	123404	4"
Ford Super Duty	up to 2-28-99	123601	6",8"
JEEP			
Jeep Wrangler JK (Rear)	07-14	124308	2" & 3"
Jeep Wrangler JK (Front)	07-14	124452	4.5"
Jeep Wrangler JK (Rear)	07-14	124457	4.5"
Jeep Wrangler TJ (Rear)	97-06	124303	3"
Jeep Wrangler TJ (Rear)	97-06	124459	4.5"
Jeep Wrangler YJ*	87-95	124004	2" & 3.5"
Jeep Wrangler YJ (Front)	87-95	124501	5"-6"
Jeep Cherokee XJ/MJ	84-01	124007	3"
Jeep ZJ	93-98	124007	3"
Jeep ZJ (Rear)	93-98	124209	2"
Jeep Grand Cherokee WJ	99-04	124402	4"

Notes

1. Tie Rod Ends on adjustable drag link are not covered under warranty. These are a wear item and are available separately #081403.
2. #082501 3" Steering Block fits all open knuckle, 3-bolt Dana 44 or Corporate axles including Dodge, GMC, and pre-1980 Ford F-250.
3. Does not fit production codes prior to 3-1-99. (Use #083401).
4. Increases turning radius on this application (cannot turn as sharp).
5. 3" Steering Block replacement stud kit #082001.



TIE ROD END KITS

Application	Year	Part#	Part# Stamp
DODGE			
1/2 Ton Truck	2013	082603	20277
1/2 Ton Truck	06-12	082602	44066
1/2 Ton Truck	02-05	082601	44016
TOYOTA			
Tundra	07-13	087701	70110

*one per kit

Note: All kits are designed for a specific lift height and should ONLY be used with the above kits.

* #124004 contains front and rear brackets.

** With monobeam front axle.



SHIMS

Part#	Description
228000	2" x 4 Degree Shim
228001	2.5" x 4 Degree Shim
228006	2.5" x 6 Degree Shim
228013	3" x 4 Degree Shim
228015	3" x 4 Degree Shim (Dual Center Pin)
228016	3" x 4 Degree Shim (Triple Center Pin)

Note: Shims are designed to be bolted to springs. Order center pins separately.



ALIGNMENT CAMS Each

Year Range	Description	Part #	Camber/Caster Adjustment	Style
DODGE				
1994-02	Dodge 2500, 3500 4WD	129100	0- 2 3/4 Degrees	Ball Joint Cam
1994-02	Dodge 2500 2WD Trucks	129100	0- 2 3/4 Degrees	Ball Joint Cam
FORD				
1980-95	Ford F-150 & Bronco 4WD	129100	0- 2 3/4 Degrees	Ball Joint Cam
1997-03	Ford F-150	129104		Cam "D" Bolts
1980-04	Ford F-250 & F-350 4WD	129100	0- 2 3/4 Degrees	Ball Joint Cam
1983-89	Ford Ranger/Bronco II 4WD	129101	0- 3 1/8 Degrees	Ball Joint Cam
1990-91	Ford Bronco II 4WD & 2WD	129102	0- 1 3/4 Degrees*	Ball Joint Cam
1989-94	Ford Ranger 2WD	129102	0- 1 3/4 Degrees	Ball Joint Cam
1989-95	Ford Ranger 4WD	129102	0- 1 3/4 Degrees	Ball Joint Cam
1991-94	Ford Explorer 4WD & 2WD	129102	0- 1 3/4 Degrees	Ball Joint Cam
1987-95	Ford F-150, F-250, F-350 2WD	129102	0- 2 1/2 Degrees	Ball Joint Cam
2005-14	Ford F-250, F-350 4WD	129105	2 Degrees Fixed	Ball Joint Cam
JEEP				
2007-14	Jeep JK Front Lower Cam Bolts	124312		Cam "D" Bolts
1997-06	Jeep TJ Front Control Arm Cam Bolts	124311		Cam "D" Bolts
1997-06	Jeep TJ Rear Upper Pinion Cam Bolts	124319		Cam "D" Bolts
1993-98	Jeep ZJ Grand Cherokee	124311		Cam "D" Bolts
MAZDA				
1994-97	B-Series Truck	129102	0- 2 1/2 Degrees	Ball Joint Cam

*Early '90 models may require #129101
Note: Order 2 each per vehicle.



HENDRICKS CLAMPS - 4/pkg

Part#	Description
228007	2" Wide Spring Clamp
228008	2.5" Wide Spring Clamp
228009	3" Wide Spring Clamp
228010	2.5" Bolt Type Spring Clamp
228011	3" Bolt Type Spring Clamp

COIL SPRING CLIPS - 2/pkg

Description	Part #
123003	Coil Spring J Clip

CENTER PINS - PAIR

Part#	Description
228002	5/16" x 4" Center Pins
228003	3/8" x 4" Center Pins
228005	7/16" x 4" Center Pins
228012	7/16" x 6" Center Pins
228014	1/2" x 4" Center Pins

Note: Packaged center pins include nuts.

ACCESSORIES

SWAY BAR DISCONNECTS, DROP BRACKET KITS

DODGE

FORD

JEEP

SUZUKI



Ultimate Sway Bar Disconnects Feature:

- One handed operation to disconnect your sway bar
- Lower ball & socket joint allows you to connect or disconnect your sway bar easily
- Urethane hourglass upper bushing allows for a controlled flex
- Lanyard included to retain sway bar when disconnected
- Adjustable length to fine tune your sway bar angle
- Stress proof material used for ball & socket joint
- Coil is pre-loaded to eliminate any rattle
- Stainless steel coil spring
- No loose parts
- We thought of everything

#124010
Rebuild Kit



ANTI-SWAY BAR LINK KITS / DROP BRACKET KITS

Description	Year	Part #	Lift	Length	Type	Location
CHEVY						
Chevy 1/2 Ton	99-06	121623	4.5-6"	12.5" mount-to-mount	Solid	Front
Chevy 1/2 Ton (6 Lug)	88-98	121631	6"	11" mount-to-mount	Solid	Front
Chevy 3/4 Ton HD	11-15	121652	5-6.5"	12.5" mount-to-mount	Solid	Front
Chevy 3/4 Ton HD	01-10	121701	5-7"	12.5" mount-to-mount	Solid	Front
Chevy 1/2, 3/4 Ton	73-87	121632	6-8"	4" mount-to-mount	Solid	Front
Chevy S-Series-Eye to Eye	95-04	121507	5"	13" eye-to-eye	Solid	Rear
Chevy S-Series-Stem to Eye	95-04	121508	5"	5.5" extension	Solid	Rear
DODGE						
Dodge Ram 1500	06-14	122622	4-6"		Extension	Front
Dodge Ram 1500	02-05	122622	4"		Extension	Front
Dodge Ram 1500	02-05	122003	6"		Extension	Front
Dodge 1500	94-01	121451	5"		Drop Bracket	Front
Dodge 2500/3500	09-12	123411	3-6"		Drop Bracket	Front
Dodge 2500/3500	03-08	122310	3"		Extension	Front
Dodge 2500/3500	03-08	122003	6"		Extension	Front
Dodge 2500/3500	94-02	121451	6"		Drop Bracket	Front
FORD						
Ford F-250, 350	08-14	123411	4"		Drop Bracket	Front
Ford F-250, 350	08-14	121451	6-8"		Drop Bracket	Front
Ford F-250, 350	08-14	123009	6-8"	18" mount-to-mount	Solid	Rear
Ford F-250, 350	05-07	123413	4-6"		Drop Bracket	Front
Ford F-250, 350	00-04	123005	4"	15.5" eye-to-eye	Solid	Rear
Ford F-250, 350	1999	123002	2.5"	11" eye-to-eye	Solid	Front
Ford F-250, 350	1999	123004	4"	13.5" eye-to-eye	Solid	Front
F-150	97-03	123604	6"	10.5" mount-to-mount	Solid	Front
F-150 / Bronco	80-96	123401	4-6"		Drop Bracket	Front
Ford F-100, F-150	73-79	123403	4-6"	12.5" eye-to-mount	Solid	Front
JEEP						
Jeep Wrangler JK	07-14	124320	3-4.5"	9" eye-to-eye	Solid	Front
Jeep Wrangler JK	07-14	124321	5.5-6.5"	11.5" eye-to-eye	Solid	Front
Jeep Wrangler JK	07-14	124310	2-4.5"		Ultimate	Front
Jeep Wrangler JK	07-14	124603	5.5-6.5"		Ultimate	Front
Jeep Wrangler JK	07-14	124329	3"		Drop Bracket	Rear
Jeep Wrangler JK	07-14	124456	4-4.5"	11" eye-to-eye	Solid	Rear
Jeep Wrangler JK	07-14	124609	5.5-6.5"		Drop Bracket	Rear
Jeep Wrangler TJ	97-06	124451	0-2"		Ultimate	Front
Jeep Wrangler TJ	97-06	124306	0-2"	7.375" eye-to-mount	Solid	Front
Jeep Wrangler TJ	97-06	124313	2-3"	10.5" eye-to-mount	Solid	Front
Jeep Wrangler TJ	97-06	124309	2-3"	9.75" eye-to-eye	Solid	Rear
Jeep Wrangler TJ	97-06	124652	3-4.5"		Ultimate	Front
Jeep Wrangler TJ	97-06	124458	4.5"	11" eye-to-eye	Solid	Rear
Jeep Wrangler TJ	97-06	124651	6.5"		Ultimate	Front
Jeep Wrangler YJ	87-95	124001	3.5-4.5"	11" eye-to-eye	Solid	Front
Jeep Wrangler YJ	87-95	124352	3.5"		Ultimate	Front
Jeep Wrangler YJ	87-95	124503	4.5-6"		Ultimate	Front
Jeep Wrangler YJ	87-95	124013	5-6"	13" eye-to-eye	Solid	Front
Jeep CJ5, CJ7	76-86	124002	4"	9.75" eye-to-eye	Solid	Front
Jeep Cherokee XJ	84-01	124306	3"	7.375" eye-to-mount	Solid	Front
Jeep Cherokee XJ	84-01	124451	3-4.5"		Ultimate	Front
Jeep Cherokee XJ	84-01	124652	6.5"		Ultimate	Front
Jeep Grand Cherokee ZJ	93-98	124306	3"	7.375" eye-to-mount	Solid	Front
Jeep Grand Cherokee ZJ	93-98	124451	3-4.5"		Ultimate	Front
Jeep Grand Cherokee WJ	99-04	124409	4"		Solid	Rear
Jeep Grand Cherokee WK	05-07	124412	4"	13" eye-to-eye	Solid	Front
TOYOTA						
Tundra	07-13	128701	4.5"-7"			Front
FJ Cruiser	07-12	128309	3"		Solid	Rear



#124331

Front Fixed Lower Control Arm

- Durometer specific vulcanized rubber or polyurethane bushings
- 1/4" wall, 1-3/4" O.D. center tube
- Formed arms to increase tire clearance
- Good for 2" or 3" lifts



#124332

Front Adjustable Lower Control Arm With Forged Flex Ends

- 1-1/4", 12 threaded forged flex ends
- Easily rebuildable flex ends
- 15 degrees of twist allowed to increase droop and compression without transferring rotational load
- Center steel ball is controlled by urethane races to absorb shock and vibration while increasing off road performance
- Vulcanized rubber bushing at the standard end for daily or off road use



#124333

Rear Adjustable Upper Control Arm With Forged Flex Ends

- 12mm ID x 2" width, 1" RH thread
- Center steel ball is controlled by urethane races to absorb shock and vibration while increasing off road performance
- Easily rebuildable flex ends



#124338

Rear Adjustable Lower Control Arm With Forged Flex Ends

- 1-1/4", 12 threaded forged flex ends
- Easily rebuildable flex ends
- 15 degrees of twist allowed to increase droop and compression without transferring rotational load
- Center steel ball is controlled by urethane races to absorb shock and vibration while increasing off road performance

2007-2014 JEEP WRANGLER JK

FRONT UPPER

#124333... Adjustable with Forged Flex Ends 50JK732

REAR UPPER

#124337... Adjustable with Forged Flex Ends and Rubber Bushings 03JK872

#124367... Adjustable with Forged Flex Ends and Polyurethane Bushings 03JK872

FRONT LOWER

#124331... Fixed Length with Rubber Bushings 07JK191

#124361... Fixed Length with Polyurethane Bushings 07JK191

#124332... Adjustable with Forged Flex Ends and Rubber Bushings 32JK903

#124362... Adjustable with Forged Flex Ends and Polyurethane Bushings 32JK903

REAR LOWER

#124339... Fixed Length with Rubber Bushings 07JK191

#124369... Fixed Length with Polyurethane Bushings 07JK191

#124338... Adjustable with Forged Flex Ends and Rubber Bushings 32JK903

#124368... Adjustable with Forged Flex Ends and Polyurethane Bushings 32JK903

1997-2006 JEEP WRANGLER TJ

FRONT UPPER

#124441... Fixed Length with Rubber Bushings 96JK421

#124442... Fixed Length with Polyurethane Bushings 00JK531

#124341... Adjustable with Forged Flex Ends 97JK622

REAR UPPER

#124445... Fixed Length with Rubber Bushings 13JK541

#124446... Fixed Length with Polyurethane Bushings 39JK561

#124349... Adjustable with Forged Flex Ends and Rubber Bushings 27JK752

#124447... Adjustable with Forged Flex Ends and Polyurethane Bushings 27JK752

FRONT & REAR LOWER

#124327... Fixed Length with Rubber Bushings 95JK451

#124427... Fixed Length with Polyurethane Bushings 95JK451

#124340... Adjustable with Forged Flex Ends and Rubber Bushings 32JK903

#124360... Adjustable with Forged Flex Ends and Polyurethane Bushings 32JK903

1984-2001 JEEP CHEROKEE XJ

FRONT UPPER

#124441... Fixed Length with Rubber Bushings 96JK421

#124442... Fixed Length with Polyurethane Bushings 00JK531

#124341... Adjustable with Forged Flex Ends 97JK622

FRONT LOWER

#124327... Fixed Length with Rubber Bushings 95JK451

#124427... Fixed Length with Polyurethane Bushings 95JK451

#124340... Adjustable with Forged Flex Ends and Rubber Bushings 32JK903

#124360... Adjustable with Forged Flex Ends and Polyurethane Bushings 32JK903

1993-1998 JEEP GRAND CHEROKEE ZJ

FRONT UPPER

#124441... Fixed Length with Rubber Bushings 96JK421

#124442... Fixed Length with Polyurethane Bushings 00JK531

#124341... Adjustable with Forged Flex Ends 97JK622

REAR UPPER

#124445... Fixed Length with Rubber Bushings 13JK541

#124446... Fixed Length with Polyurethane Bushings 39JK561

#124349... Adjustable with Forged Flex Ends and Rubber Bushings 27JK752

#124447... Adjustable with Forged Flex Ends and Polyurethane Bushings 27JK752

FRONT LOWER

#124327... Fixed Length with Rubber Bushings* 95JK451

#124427... Fixed Length with Polyurethane Bushings* 95JK451

#124340... Adjustable with Forged Flex Ends and Rubber Bushings* 32JK903

#124360... Adjustable with Forged Flex Ends and Polyurethane Bushings* 32JK903

REAR LOWER

#124469... Fixed Length with Rubber Bushings 09JK461

#124468... Fixed Length with Polyurethane Bushings 93JK181

#124340... Adjustable with Forged Flex Ends and Rubber Bushings 32JK903

#124360... Adjustable with Forged Flex Ends and Polyurethane Bushings 32JK903

*Requires 124081 spacer washer kit

2003-2013 OE 4-LINK DODGE RAM 2500/3500

#122322... Fixed Length Upper/Lower with Poly Bushings 2"-3" Lift 78DK363

2000-2002 DODGE RAM 2500/3500, 200-2001 DODGE RAM 1500

#122305... Fixed Length Upper/Lower with Poly Bushings 2"-3" Lift 04DK913

1994-1999 DODGE RAM 1500/2500/3500

#122302... Fixed Length Upper/Lower with Poly Bushings 2"-3" Lift 63DK313



ATTENTION: Look for this stamp indicating kits that utilize the new BDS Forged Flex Ends!

For replacement bushings see pg. 141

ACCESSORIES

LONG ARM UPGRADES



FORD

- 1980-1996 F150/Bronco 4WD
4-6" Extended Radius Arm Upgrade
#123006.....36FK347
- 2005-2014 F250/F350 4WD
4"-6" Lift
#123011/123012.....89FK4301
8" Lift
#123011/013810.....21FK478

JEEP



- JK
4-8.5" Lift, Front/Rear 4-Link LA Upgrade
#984H.....38JK0671



- TJ
4-8.5" Lift, Front/Rear 4-Link LA Upgrade
#983H.....67JK4551



- XJ
4.5-8.5" Lift, Front 4-Link LA Upgrade
#981H.....97JK949

- ZJ
4.5-8.5" Lift, Front/Rear 4-Link LA Upgrade
Standard Arms
#985H.....90JK7561
Flex Arms
#986H.....18JK7571

DODGE

- 1994-2001 RAM 1500 4WD - 5"-6" Lift
#122505.....37DK294
- 1994-2002 RAM 2500/3500 4WD - 5"-6" Lift
#122505.....37DK294
- 2003-2013 RAM 2500 4WD - 6"-8" Lift
#012801/012802.....82DK339
- 2003-2012 RAM 3500 4WD - 6"-8" Lift
#012801/012802.....82DK339
- 2014 RAM 2500 4WD - 4"-8" Lift
#012403/122404.....25DK309
- 2013-2014 RAM 3500 4WD - 4"-8" Lift
#012403/122404.....25DK309



For replacement bushings
see pg. 141



FORGED FLEX END KIT

- Heavy-duty forged steel housing use 1-piece flex balls and polyurethane races
- Comes completely assembled with grease fitting and jam nut
- 1 end per kit

#124033.... Large Forged Flex End - 1-1/4"-12 Thread - 9/16" Bolt x 2-5/8" Wide.....	65JK35
#124034.... Small Forged Flex End - 1"-14 Thread - 7/16"(10mm) Bolt x 2" Wide.....	52JK34
#124035.... Small Forged Flex End - 1"-14 Thread - 12mm Bolt x 2" Wide.....	52JK34
#124037.... Small Forged Flex End - 1"-14 Thread - 9/16" Bolt x 2-5/16" Wide.....	52JK34

FORGED FLEX END REBUILD KITS

- Kits include races, washer and snap ring to rebuild 1 end

#124043.... Large Forged Flex End Rebuild Kit.....	32JK9
#124044.... Small Forged Flex End Rebuild Kit.....	61JK7

RUBBER BUSHINGS BUILDER'S KIT - JEEP LCA

- Kit includes 1 weld-on eye, and 1 press-in rubber bushing

#124039.... 2.25" x .118" DOM control arm plus bushing.....	27JK52
---	--------

WELD-IN THREADED TUBE INSERTS

- Weld into the appropriate sized tube to create custom control arms, track bars, etc. using the BDS line of forged ends

#124040.... 1-1/4"—12 Thread for 1.5" ID Tube.....	93JK61
#124041.... 1"—14 Thread for 1.375" ID Tube.....	93JK61
#124042.... 1"—14 Thread for 1.25" ID Tube.....	93JK61

FLEX END REBUILD TOOL

- Tools are designed for traditional BDS fabricator style flex ends or new forged flex ends
- Great for assembling new ends, trail fixes or replacing bushings
- Can be used with hand tools with arm still partially installed on vehicle or in a bench vise
- Includes tools for both large and small flex ends

#124032.... Flex End Rebuild Tool.....	27JK52
--	--------

FORGED UNI-BALL END KIT

- Unique design incorporates the popular uni-ball (COM bearing) design with a forged flex end housing
- Fully rebuildable, works with any standard 7/8" mis-alignment inserts (not included) allowing for numerous mounting bolts and widths
- Great for many custom applications including track bars, control arms and traction bars
- Uni-ball has injection molded nylon race for smooth, quiet operation and long life
- Comes completely assembled and includes jam nut
- 1 end per kit

#124036.... Forged Uni-Ball End - 1"-14 Thread - 7/8" Uni-Ball.....	82JK44
#124048.... Misalignment Spacers (pair) - 1/2" Bolt x 2" Wide.....	30JK81
#124049.... Replacement Uni-Ball Kit - includes Uni-ball and Snap Ring.....	36JK22

FABRICATOR FLEX END KITS

- Weld on flex eye kits, all parts needed to make a complete control arm
- Includes 2 flex eyes ready to weld on and assemble

#124028.... Large Flex Eye Fabricator Kit - 9/16" Bolt x 2-5/8" Wide.....	78JK87
#124029.... Small Flex Eye Fabricator Kit - 7/16"(10mm) Bolt x 2" Wide.....	20JK47

FABRICATOR FLEX END REBUILD KITS

- Kits include races, washers and snap ring to rebuild 2 ends
- Use to rebuild fabricator flex ends or BDS control arm ends where eye is welded to arm

#124030.... Large Fabricator Flex End Rebuild Kit.....	32JK82
#124031.... Small Fabricator Flex End Rebuild Kit.....	60JK82



For replacement bushings see pg. 141

ACCESSORIES GM FRAME SUPPORT, TRANSFER CASE DROP KITS, BLOCKS, LEAF SPRING ANTI-FRICTION PADS, BRAKE LINES

One-Piece Crimp Design Protective Vinyl Cover Stainless Steel Braid Protective Layer Kevlar Braid

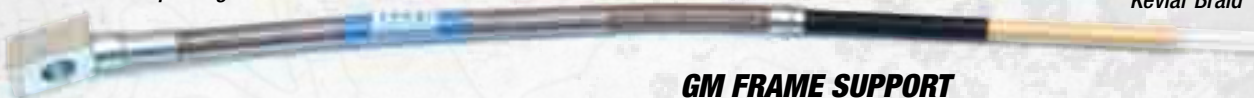

KEVLAR LINED STAINLESS STEEL BRAIDED BRAKE LINES

Application	Front	Rear	Lift	Length
-------------	-------	------	------	--------

CHEVY

07-14 Silverado, Sierra, Tahoe, Yukon 4WD 1500	101002		6"	29.5"
1988-98 K1500, K2500 Truck	101001	101009	6"	25"
1992-98 Blazer/Jimmy/Tahoe/Yukon 4WD Full Size	101001	101009	6"	25"
1992-98 Suburban 4WD	101001	101009	6"	25"
2011-15 Silverado/Sierra 2500 HD	101011		4-7"	28"

DODGE

2006-14 Dodge Ram 1/2 Ton	102002		6"	22.5"
2003-11 Dodge Ram 3/4 Ton, 1 Ton	102001	102009	6"	31"/27"
2012 Dodge Ram 3/4 Ton, 1 Ton	102001		6"	31"/27"
2013 Ram 1 Ton	102003		4-8"	41"
2014 Ram 3/4 Ton	102003		4-8"	41"

FORD

2004-08 F150 4WD	103002		6"	23"
2005-07 F250, F350 4WD	103001	103009	6"- 8"	30"/26"
2008-14 F250, F350 4WD	103801	103009	6"- 8"	33"/26"

JEEP

2007-14 Wrangler JK	104002	104006	4-1/2" to 6-1/2"	22.5"/25"
1997-06 Wrangler TJ	104001	104009	3" to 6-1/2"	26"/26"
1987-95 Wrangler YJ	104001	104007	4-1/2" to 6-1/2"	26"/20.5"
1984-01 Cherokee XJ	104001	104008	3" to 6-1/2"	26"/20.75"

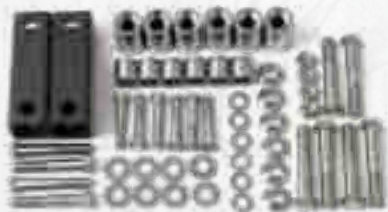

TRANSFER CASE DROP KITS

Application	Year	Part #
-------------	------	--------

CHEVY

Chevy Blazer, Jimmy, Suburban	73-91	121000
Chevy 1/2, 3/4 Ton Truck 4WD	73-87	121000

DODGE

Dodge 3/4 Ton Truck—Diesel	03-05	122602*
Dodge 3/4 Ton Truck—Gas	03-05	122603*
Dodge 3/4 Ton Truck—Manual Diesel	06-12	122605*
Dodge 3/4 Ton Truck—Manual Gas	06-09	122605*
Dodge 3/4 Ton Truck—Auto Gas & Diesel	06-07	122605*
Dodge 3/4 Ton Truck—Auto Diesel	07-12	122606*

JEEP

Jeep CJ	76-86	124000
Jeep Wrangler YJ	87-95	124003
Jeep Wrangler TJ	97-02	124304
Jeep Wrangler TJ - 1-5/8" Drop	03-06	124305
Jeep Wrangler TJ - 3/4" Drop	03-06	124315
Jeep Cherokee XJ	84-01	124006
Jeep Grand Cherokee ZJ	93-98	124026
Jeep Grand Cherokee WJ	99-04	124027

*Will not work with 6 speed manual transmission

GM FRAME SUPPORT

- Add support to the weakest frame area
- Helps stop frame cracking in gear box location

#121001..... GM Frame Support Kit

Note: 73-87 1/2, 3/4 Ton PU 4WD, 88-91 Blazer, Jimmy, Suburban 4WD.

LEAF SPRING ANTI-FRICTION PADS

#129007.....2" Wide Pads

#129008.....2.5" Wide Pads

#129009.....3" Wide Pads

Notes: Will only fit BDS leaf springs. All of these kit #'s come with 10 individual pads.

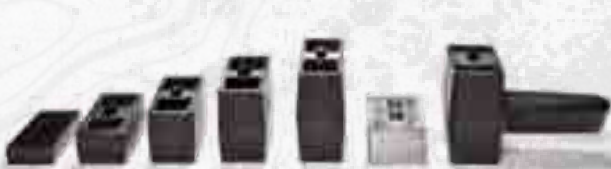

STANDARD BLOCKS

- Blocks are made of cast iron for strength
- Tapered for correct pinion angle
- Steel pin and hole are offset to restore axle position
- Blocks come in pairs
- 2", 3", 4", 5" blocks are black powder coated

Part #	Description	Tapered	Pin Size	Hole Size	Notes
069589	5/8"x2.5" Blocks	No	N/A	3/8"	1,2,3
069108	1"x2.5" Blocks	No	N/A	7/16"	1,2,3
069109	1"x3" Blocks	No	N/A	1/2"	1,2,3
069209	2" Blocks	Yes	9/16"	9/16"	2,3
069207	2" Blocks	Yes	5/8"	11/16"	2,3
069206	2" Blocks	Yes	3/4"	13/16"	2,3
069309	3" Blocks	Yes	9/16"	9/16"	2,3
069308	3" Blocks	Yes	7/8"	7/8"	2,3
069307	3" Blocks	Yes	5/8"	11/16"	2,3
069306	3" Blocks	Yes	3/4"	13/16"	2,3
069409	4" Blocks	Yes	9/16"	9/16"	2,3
069407	4" Blocks	Yes	5/8"	11/16"	2,3
069406	4" Blocks	Yes	3/4"	13/16"	2,3
069509	5" Blocks	Yes	9/16"	9/16"	2,3
069507	5" Blocks	Yes	5/8"	11/16"	2,3
069517	5" Blocks	No	5/8"	11/16"	2,3
069506	5" Blocks	Yes	3/4"	13/16"	2,3

Notes

1. 5/8" and 1" blocks are made to be attached directly to the leaf pack via the center pin. Order center pins separately. See page 76.

2. Lift blocks are for rear axles only!

3. Not for use with Quadra-Steer rear axles.

SPECIALTY BLOCKS

Part #	Application	Ht.	Flat	Pin Size	Pin Qty	Bump Stop Wing	Notes
069526	04-08 F150 4WD	5"	Yes	3/4"	2	Yes	
069527	99-07 F250, F350	5"	Yes	5/8"	1	Yes	
069216	04-14 F150 4WD	2"	Yes	3/4"	2	No	
069417	07-14 Tundra 4WD	4"	Yes	5/8"	1	No	
069119	09-14 F150 4WD	1"	Yes	n/a	2	No	1
069516	03-12 Dodge 3/4, 1-Ton	5"	Yes	3/4"	1	Yes	2
069537	08-14 F250, F350	5"	Yes	5/8"	1	Yes	3

Notes

1. This block is designed to attach directly to the leaf pack via new center pins (#228014 x 2)

2. Includes 01599 press in center pins required for this block to be used.

3. Offset center pin and includes matching u-bolt plates.

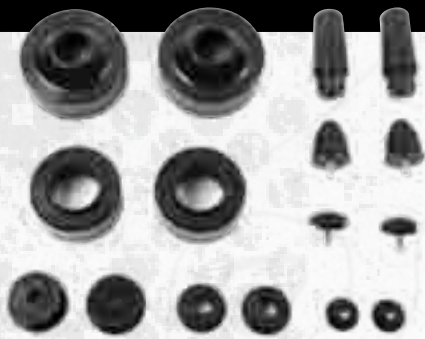

URETHANE PRODUCTS

Part #	Description	Color
170001	Pyramid Bump Stop	Black
170012	Low Profile Bump Stop	Black
172301	Dodge 3" Extended Bump Stops	Black
172501	Dodge 5" Extended Bump Stops	Black
174001	TJ, ZJ, or XJ(84-96) Extended Bump Stops	Black
174002	97-01 XJ Small Diameter Bump Stop	Black
174101	Jeep TJ Coil Spring Spacers 0.75"	Black
174102	'07 Wrangler JK Front 2" Coil Spacer	Black
174109	'07 Wrangler JK Rear 2" Coil Spacer	Black
174201	Jeep TJ, XJ, ZJ Coil Spring Spacers 1.75"	Black

Note: All products come as a pair.

BUSHINGS & SLEEVE KITS

Year	Description	Part#	Notes
CHEVROLET/GMC			
1973-87	Front 1/2, 3/4 Ton Truck, Blazer, Suburban Spring Eye Bushings	071002	
1973-91	Rear 1/2 Ton Truck, Blazer, Suburban Spring Eye Bushings	071009	
1988-91	Front Blazer, Jimmy, Suburban 4WD	071003	
1995-05	S-Series 4WD Control Arm Bushing Kit (does one control arm)	071008	2
1988-98	Rear 1/2 Ton Spring Eye Bushings	071107	
1999-06	Rear 1/2 Ton Spring Eye Bushings	071007	2
2007-13	Rear 1/2 Ton Spring Eye Bushings	071006	
DODGE			
1969-93	Front W100/200 Except 200HD Truck Spring Eye Bushings - Rear	072001	
1994-99	Link Bushing/Sleeve Kit 1/2, 3/4 Ton Truck 4WD (does all 4 links) Short Arm	072005	2
1994-99	Link Bushing/Sleeve Kit 1/2, 3/4 Ton Truck 4WD (does all 4 links) Long Arm	072106	2
2000-01	Link Bushing/Sleeve Kit 1/2, 3/4 Ton Truck 4WD (does all 4 links) Short Arm	072006	2
2000-01	Link Bushing/Sleeve Kit 1/2, 3/4 Ton Truck 4WD (does all 4 links) Long Arm	072105	2
2003-09	Link Bushing/Sleeve Kit 3/4 Ton Truck 4WD (does all links) Short Arm	072307	2
2010-12	Link Bushing/Sleeve Kit 3/4 Ton Truck 4WD (does all links) Short Arm	072207	2
2003-12	Link Bushing/Sleeve Kit 3/4 Ton Truck 4WD (does all links) Long Arm	072107	2
FORD			
1980-96	BDS Extended Radius Arm Bushings (both sides)	073002	2
1997-03	F-150 Rear Spring Bushing Kit	073009	2
2005-13	F250/F350 4-Link Bushing Kit	073003	
JEEP			
LEAF SPRING/SHACKLE BUSHING KITS			
1976-86	Front CJ Spring Eye Bushings	074001	
1976-86	Rear CJ Spring Eye Bushings	074009	
1976-86	CJ Shackle Bushing Kit (does all 4 frame/shackle mounts)	074002	
1987-95	YJ Front or Rear Spring Eye Bushings (BDS Springs)	074000	
1987-95	YJ Front or Rear Spring Eye Bushings (Stock Springs)	074006	
1987-95	YJ Frame/Shackle Kit (does all 4 frame/shackle mounts)	074004	
1984-01	XJ Rear Spring Eye Bushing Kit	074008	
1984-01	XJ Stock Shackle Bushing Kit (does both shackles)	074101	
1984-01	XJ BDS Boomerang Shackle Bushing Kit (does both shackles)	074109	
TRACK BAR BUSHING KITS			
2007-13	JK BDS Front Track Bar Bushing Kit (does both ends)	074104	
1984-06	TJ, XJ, ZJ BDS Front Track Bar Bushing Kit - Axle Mount (124423)	074102	
1984-06	TJ, XJ, ZJ BDS Front Track Bar Bushing Kit - Axle Mount (124601, 602, 611)	074020	
1984-06	TJ, XJ, ZJ BDS Front Track Bar Flex End Kit - Frame Mount	074113	
1984-06	TJ, XJ, ZJ BDS Front Track Bar Flex Joint Bushing and Ball Stud Kit	074103	
CONTROL ARM BUSHING KITS - 1ST GENERATION ARMS			
1984-2014	JK, TJ, XJ, ZJ BDS Lower Control Arm Bushing Kit (Includes 8 bushings/4 sleeves)	074005	3
1984-2014	JK, TJ, XJ, ZJ BDS Lower Control Arm Bushing Kit (Includes 4 bushings/2 sleeves)	074100	3
1984-2006	TJ, XJ, ZJ BDS Upper Control Arm Bushing Kit (Includes 4 bushings/2 sleeves)	074007	3
CONTROL ARM BUSHING KITS - 2ND GENERATION ARMS			
1984-2014	JK, TJ, XJ, ZJ BDS Lower Control Arm Bushing Kit (Includes 4 bushings/2 sleeves)	074126	3
1984-2006	TJ, XJ, ZJ BDS Upper Control Arm Bushing Kit (Includes 4 bushings/2 sleeves)	074125	3
1984-2014	JK, TJ, XJ, ZJ BDS Lower Control Arm Rubber-to-Poly Conversion Kit (4 bushings/2 sleeves/2 zerks)	074120	3, 5
1984-2014	JK, TJ, XJ ZJ BDS Upper Control Arm Rubber-to-Poly Conversion Kit (4 bushings/2 sleeves/2 zerks)	074121	3
2007-2014	JK BDS Rear Upper Control Arm Rubber-to-Poly Conversion Kit (4 bushings/2 sleeves/2 zerks)	074122	3
1984-2014	JK, TJ, XJ ZJ BDS Lower Control Arm Replacement Rubber Bushing (1 bushing)	074123	3, 4
1984-2014	JK (Frt Only), TJ, XJ, ZJ BDS Upper Control Arm Replacement Rubber Bushing (1 bushing)	074124	3, 4
2007-2014	JK (Rear Only) BDS Upper Control Arm Replacement Rubber Bushing (1 bushing)	074127	3, 4
SUZUKI			
1985-95	Samurai Front or Rear Spring Eye Bushings	077000	1

**ORDER TWO BUSHING/SLEEVE KITS
WHEN ORDERING TWO SPRINGS**

1. Includes shackle bushings
2. These are replacement bushings and sleeves for BDS springs/components only
3. 1st generation arms use 1-1/2" OD bushings, 2nd generation arms use 1-7/8" OD bushings
4. Will work as factory control arm replacement bushings also
5. ZJ applications may require front frame mount spacer washer kit #124081 if not already equipped

BDS CLOTHING & APPAREL



#22013BLK

#22012BLU

BDS Logo T-Shirt

Nothing goes with your new lift truck like BDS swag! These shirts come in black and blue with BDS logos on the front and back. These Gildan shirts are 50/50 pre-shrunk with wicking performance DryBlend technology and tagless comfort.



#22014PNK

BDS Logo Women's T-Shirt

These women's fitted t-shirts are 100% cotton and are surprisingly stretchy. We highly recommend buying your girlfriend or wife a size smaller than normal and enjoy. Available in S, M, or L.

CLOTHING & APPAREL

Part #	Description	Color	Sizes
22012BLU*	BDS T-Shirt	Blue	S, M, L, XL, XXL, XXXL
22013BLK*	BDS Tread T-Shirt	Black	S, M, L, XL, XXL, XXXL
22014BLK*	BDS Women's T-Shirt	Black	S,M,L,XL
22009BLK*	BDS Hoodie	Blue	S, M, L, XL-XXXXXL
22009BLU*	BDS Hoodie	Black	S, M, L, XL-XXXXXL
22009PNK*	BDS Hoodie	Pink	S, M, L, XL-XXXXXL
221006	BDS Hat	Black	S-M
221007	BDS Hat	Black	L-XL
22050	BDS Drink Koozie	Black	one size fits most

*After the part number add the letter(s) to designate size.



#221006/221007 - BDS Stretch Fit fitted hats



#22009



BDS Logo Hoodie

These Gildan heavy blend hoodies will keep you warm on the coldest of days. These 50/50 pre-shrunk hoodies are available in Black, Blue and Pink and have the BDS logo on the front and back.



#22050 - Drink Koozie

PROMOTIONAL FLYERS

Part #	Description	Qty
22100	BDS All Vehicle Flyer	25
22101	Chevy/GMC Truck Flyer	25
22102	Dodge/Ram Truck Flyer	25
22103	Ford Truck Flyer	25
22104	Jeep Vehicle Flyer	25
22105	Toyota Truck Flyer	25
22106	'07-14 GM1500 Truck Flyer	25
22107	'01-15 GM2500 Truck Flyer	25
22108	'09-14 Ram1500 Truck Flyer	25
22109	'03-13 Ram 2500/3500 Truck Flyer	25
22110	'13-14 Ram 2500/3500 Truck Flyer	25
22111	'09-14 F150 Truck Flyer	25
22112	'05-14 F250/F350 Truck Flyer	25
22112	'07-14 Jeep JK Flyer	25
22113	'97-06 Jeep TJ Flyer	25
22114	'84-01 Jeep XJ Flyer	25



PUBLICATIONS

Part #	Description	Qty
Catalog	2014 Product Catalog	1
Price	2014 USA Jobber Price	1

CHEVROLET/
GMC

DODGE

FORD

JEEP

SUZUKI

TOYOTA

POSI-LOK

SHOCKS/
STEERING
STABILIZERS

APPAREL/
PROMOTIONAL

PRODUCT
SPECS

VEHICLE
SPECS





#22095

DISPLAY MATERIALS

Part #	Description	Size
22095	Indoor Lighted Sign	13" x 24"
22190	Indoor/Outdoor Banner	18" x 36"
22191	Indoor/Outdoor Banner	48" x 72"
22192	Indoor/Outdoor Banner	18" x 96"



#22192



#22190



#22191

BDS SUSPENSION

#222762

DIE CUT STICKERS (ea.)

Part #	Description	Color
222780	Decal 2" x 5"	Blue/Grey
222764	3.5" x 12" Die-Cut Decal	Silver
222765	3.5" x 12" Die-Cut Decal	Black
222767	2.5" x 40" Die-Cut Decal	Silver
222763	.75" x 10" Die-Cut Decal	Brushed Silver



#222780



#222765 - Black
#222764 - Silver



#UAPOSTER2013

#UADVD2013

ULTIMATE ADVENTURE PROMOTIONAL

Part #	Description	Size
UADVD2013	DVD	65min.
UAPOSTER2013	Poster	24" x 36"



For more on this build head to bds-suspension.com/blog

PROJECT KJ

SPECIFICATIONS

LEAF SPRINGS, ADD-A-LEAF

DODGE

FORD

JEEP

SUZUKI

TOYOTA

POSI-LOK

SHOCKS/
STEERING
STABILIZERS

APPAREL/
PROMOTIONAL

PRODUCT
SPECS

VEHICLE
SPECS

LEAF SPRING SPECIFICATIONS

Part #	Eye to Eye Dimension	Free Height Dimension	Eye to Center Pin Front	Eye to Center Pin Rear	Eye (F/R) Diameters	# of Leafs Per Pack	Width	Weight	Center Pin Size
001201	45.500	3.313	23.250	23.250	1.5/1.125	5	2.5	44.55	3/8
001401	45.125	4.750	23.000	22.125	1.5/1.125	5	2.5	40.00	3/8
001402	43.000	4.500	22.250	22.250	1.5/1.125	6	2.5	48.75	3/8
001408*	52.875	10.000	26.500	31.000	RB136/RB136	6	2.5	71.10	3/8
001409	48.875	10.000	26.625	27.625	1.5/1.5	6	2.5	55.85	3/8
001509*	60.500	11.500	32.500	33.250	RB250/RB172	5	2.5	78.90	3/8
001551	44.500	6.750	23.500	24.000	1.5/1.125	6	2.5	48.55	3/8
001559	61.000	10.750	32.500	33.500	1.5/1.5	5	2.5	76.00	3/8
001608*	52.250	11.500	26.750	31.375	RB136/RB136	6	2.5	73.25	3/8
001609	48.250	11.000	26.500	28.000	1.5/1.5	6	2.5	60.15	3/8
001801	43.750	8.500	24.000	24.000	1.5/1.125	5	2.5	44.56	3/8
001809	48.000	13.500	27.875	29.125	1.5/1.5	6	2.5	67.05	3/8
002209*	56.250	10.000	28.375	32.250	RB158/RB158	5	3	78.00	1/2
002458*	56.250	10.500	28.750	32.500	RB158/RB158	5	3	76.00	1/2
002459*	56.750	9.750	28.500	32.500	RB136/RB136	5	2.5	65.00	3/8
002501	46.000	5.500	23.375	24.375	1/1	5	2.5	78.00	3/8
002506*	58.500	12.000	31.875	34.125	RB136/RB136	4	2.5	69.00	3/8
002508*	60.875	10.250	30.750	31.750	RB227/RB227	7	3.0	102.00	1/2
002509	49.000	9.875	25.000	29.000	1/1	5	2.5	49.60	3/8
003202*	52.375	6.125	28.000	27.628	RB198/RB132	5	3	71.00	7/16
003208*	52.250	7.500	24.000	31.000	RB158/RB152	6	3	79.00	7/16
003401*	50.500	6.500	24.375	28.625	RB155/RB155	5	3	73.00	7/16
003402*	52.375	8.130	27.750	28.375	RB198/RB132	5	3	74.00	7/16
003408*	52.875	9.375	25.000	32.000	RB158/RB152	6	3	80.00	7/16
003509	54.000	11.000	26.000	32.250	RB198/RB152	5	3	71.50	1/2
003559	54.250	13.000	27.750	34.750	1.5/1.5	5	2.5	68.00	7/16
003602*	52.750	8.250	28.000	28.375	RB198/RB132	10	3	98.00	7/16
003608*	52.000	11.250	25.500	32.750	RB158/RB152	6	3	81.00	7/16
003609*	53.000	10.750	25.250	33.000	RB227/RB158	5	3	94.80	7/16
003619*	63.000	12.500	33.000	36.750	RB177/RB178	5	3	111.00	7/16
003802*	52.000	9.500	28.000	28.500	RB198/RB132	10	3	104.00	7/16
003809*	53.000	12.750	26.250	34.000	RB227/RB158	5	3	96.80	3/8
003819*	61.500	14.500	34.000	36.500	RB177/RB178	5	3	115.00	7/16
004200	43.000	6.500	22.875	22.875	1.5/1.5	4	2.5	30.70	5/16
004209	48.625	7.250	23.000	28.750	2.5/1.75	7	2.5	51.00	5/16
004251	42.500	6.000	22.250	22.375	1.5/1	5	2	28.65	5/16
004252*	38.250	5.250	20.250	20.250	RB145/RB85	6	1.75	33.85	3/8
004258*	44.125	6.125	23.250	23.250	RB37/RB37	6	1.75	33.85	3/8
004259	42.750	6.000	22.625	22.625	1.5/1	5	2.5	35.05	5/16
004351	42.500	8.000	23.500	23.500	1.5/1.5	5	2.5	31.40	5/16
004359	42.250	8.000	23.250	23.250	1.5/1.5	4	2.5	28.60	5/16
004401	41.000	8.750	22.625	23.250	1/1.5	5	2	26.85	3/8
004402*	44.500	8.000	25.875	22.875	1.5/1.25	6	2.5	53.10	3/8
004408*	53.625	9.625	26.500	31.500	1.5/1.5	5	2.5	66.40	3/8
004409	42.000	8.500	23.250	23.250	1.5/1	4	2.5	36.45	3/8
004500	41.875	10.000	23.375	24.500	1.5/1.5	5	2.5	38.60	5/16
004509	48.625	9.750	24.375	30.125	2.5/1.75	7	2.5	51.00	5/16
007401	35.250	5.250	18.675	18.825	1.2/1.6	3	2	15.65	5/16
007409	37.000	6.500	20.125	20.375	1.6/1.2	3	2	18.00	5/16

* Includes OE style bushings installed.

See page 125 for spring bushing kits. Order one bushing kit per spring.

ADD-A-LEAF SPECIFICATIONS

Part #	Free Arch	Length	Width	Thickness
111209	6.75	38.38	2.50	0.32
113201	4.00	52.00	3.00	0.40
113206	8.00	37.75	3.00	0.32
113207	7.00	40.75	2.25	0.36
113208	7.75	42.25	3.00	0.32
113209-1	7.75	42.25	3.00	0.32
113209-2	8.00	46.25	3.00	0.32
113219	7.75	42.25	3.00	0.32*
114201	5.63	40.50	2.00	0.32
114202	6.75	42.00	2.50	0.26
114208	3.00	27.50	2.50	0.32
114209	7.38	38.13	2.50	0.32
119151	8.00	41.50	2.50	0.36
119157	6.88	45.25	2.50	0.38
119158	2.50	28.50	2.25	0.63
119159	2.25	20.00	2.25	0.40

* Dual center pin holes



COIL SPRING SPECIFICATIONS

Part #	Diam.	Rate	Length	I.D.
032209	0.843	300/550	20.75	6.125"
032301	0.875	380/525	21.75	Conical
032401	0.843	385/520	22.688	4.55"
032402	0.812	385/520	22.125	4.55"
032409	0.875	300/500	22.75	6.125"
032501	0.812	365	20.50	Conical
032503	0.843	500	23.00	Conical
032504	0.875	427	22.50	Conical
032601	0.843	365	23.625	Conical
032602	0.875	385/520	23.92	4.55"
032801	0.875	380/525	26.00	5.00"
033201	0.718	395	17.00	4"
033401	0.781	455	19.25	4"
033402	0.718	410	18.25	3.5"
033403	0.750	415	20.00	4"
033404	0.812	485	20.00	4"
033411	0.843	425	23.875	4.17"
033412	0.812	385	23.50	4.17"
033601	0.812	455	21.25	6"
033602	0.718	410	20.00	6"
033603	0.781	400	22.25	4"
033604	0.843	510	21.85	4"
033609	0.812	265/380	24.00	5.125"
033611	0.843	425	25.875	4.17"
033612	0.843	385	25.50	4.17"
033811	0.875	425	27.875	4.17"
033812	0.843	385	27.500	4.17"
034201	0.625	435	15.00	3.2"
034202	0.562	180	18.375	4.00"
034203	0.593	240	15.88	3.85"
034204	0.563	158	18.50	4"
034205	0.593	210	12.75	4.5"
034206	0.625	200	13.75	5.375"
034207	0.656	240	14.00	4.66"
034208	0.562	200	15.63	4"
034209	0.593	180	16.00	4"
034211	0.625	240	17.25	4"
034301	0.625	240	18.50	4"
034302	0.563	158	19.50	4"
034308	0.625	200	14.75	5.375"
034311	0.593	160	18.875	4"
034319	0.593	180	17.00	4"
034359	0.656	240	15.500	4.66"
034401	0.625	240	18.250	3.85"
034408	0.656	200	15.75	5.375"
034409	0.593	200	17.625	4.05"
034411	0.593	175	19.75	4.00"
034419	0.53	180	18.00	4.00"
034451	0.594	175	20.50	4.02"
034452	0.656	240	20.13	4.03"
034453	0.687	240	20.875	4.03"
034611	0.625	175	21.75	4"
034619	0.625	180	20.375	4"
034651	0.656	225	21.875	4"
034652	0.687	240	21.750	4.03"
034653	0.687	240	22.875	4.03"
034658	0.625	200	19.625	4.05"
034659	0.718	250	17.25	5.375"
034852	0.687	240	23.75	4"
037201	0.526	340	11.75	2.84"
037209	0.526	280	15.75	3.25"
038209	0.656	185	16.75	5.15"



- Springs are either cold wound with chrome silicon 9254 or hot wound with 5160 to guarantee long life.
- A polyester based powder coat is applied to ensure flexibility and durability
- Each spring is preset with a hydraulic stress to reduce fatigue in the steel and prevent sagging.
- Shot peening increases tensile strength and allows for maximum wheel travel without sacrificing the life of the spring.
- BDS coil springs are designed to withstand full coil bind. In other words, you can smash our coils to totally flat and they will return to their original height.

Note: All coil springs are black powder coated and are sold in pairs.

SPECIFICATIONS

4WD ALIGNMENT (FRONT)

Model	Year	Left Caster	Right Caster	Camber	Total Toe
CHEVROLET/GMC					
Avalanche 2500	01-06	4.10° ± 1.00°	4.70° ± 1.00°	0.25° ± 0.50°	0.10" ± 0.20"
S-Series Truck, Blazer ZR2	00-03	2.80° ± 1.00°	3.30° ± 1.00°	0.00° ± 1.00°	0.05" ± 0.10"
S-Series Truck, Blazer ZR2	95-99	3.00° ± 1.00°	3.00° ± 1.00°	0.00° ± 0.50°	0.05" ± 0.05"
S-Series Truck, Blazer ZR2	88-94	3.00° ± 1.00°	3.00° ± 1.00°	1.50° ± 1.50°	0.25" ± 0.20"
Silverado/Sierra 1500—Regular & Ext Cab	99-06	3.50° ± 1.00°	4.50° ± 1.00°	0.25° ± 0.50°	0.05" ± 0.10"
Silverado/Sierra 1500—Crew Cab	99-06	4.25° ± 1.00°	4.75° ± 1.00°	0.25° ± 0.50°	0.05" ± 0.10"
K1500 Truck	07-14	3.40° ± 1.00°	3.20° ± 1.00°	0.10° ± 0.60°	0.05" ± 0.10"
K1500 Truck	88-98	3.00° ± 1.00°	3.00° ± 1.00°	0.65° ± 0.50°	0.12" ± 0.10"
K2500, K2500 HD	01-10	4.25° ± 1.00°	4.50° ± 1.00°	0.25° ± 0.50°	0.05" ± 0.10"
K10, K20, K30 Truck	77-87	8.00° ± 1.00°	8.00° ± 1.00°	1.50° ± 0.75°	0.12" ± 0.05"
K10, K20 Truck	63-76	4.00° ± 1.00°	4.00° ± 1.00°	1.00° ± 0.50°	0.00" ± 0.06"
Suburban/Tahoe, Avalanche, Escalade 1500	00-06	3.50° ± 1.00°	4.50° ± 1.00°	0.25° ± 0.50°	0.05" ± 0.10"
Suburban 1500/2500 6-Lug, Tahoe, Yukon 1500	92-99	3.00° ± 1.00°	3.00° ± 1.00°	0.65° ± 0.50°	0.12" ± 0.10"
Trailblazer	04-09	3.90° ± 0.60°	4.10° ± 0.60°	-0.50° ± 0.50°	0.10" ± 0.20"
Suburban 10, 20	77-91	8.00° ± 1.00°	8.00° ± 1.00°	1.50° ± 0.75°	0.12" ± 0.05"
Suburban 10, 20	63-76	4.00° ± 1.00°	4.00° ± 1.00°	1.00° ± 0.50°	0.00" ± 0.06"
Blazer, Jimmy Full Size	77-91	8.00° ± 1.00°	8.00° ± 1.00°	1.50° ± 0.75°	0.12" ± 0.05"
Blazer, Jimmy Full Size	69-76	4.00° ± 1.00°	4.00° ± 1.00°	1.00° ± 0.50°	0.00" ± 0.06"
DODGE					
Ram 1500	06-14	3.35° ± 0.75°	3.75° ± 0.75°	0.10° ± 0.50°	0.10" ± 0.50"
Ram 1500 Mega Cab	06-08	4.00° ± 0.50°	4.00° ± 0.50°	0.15° ± 0.25°	0.188" ± 0.063"
Ram 1500	02-05	4.00° ± 0.75°	4.00° ± 0.75°	0.00° ± 0.50°	0.10" ± 0.10"
Ram 2500	03-13	4.50° ± 0.50°	4.50° ± 0.50°	0.15° ± 0.25°	0.188" ± 0.063"
Ram 1500, 2500 Truck	00-02	2.95° ± 1.00°	2.95° ± 1.00°		0.188" ± 0.063"
Ram 1500, 2500 Truck—Std., Club & Quad Cab	94-99	3.48° ± 1.00°	3.48° ± 1.00°	0.25° ± 0.50°	0.188" ± 0.063"
(W) D150-350 Truck	83-93	2.00° ± 1.50°	2.00° ± 1.50°	0.00° ± 0.50°	0.10" ± 0.13"
(W) D100-200—Except 200HD	71-82	3.00° ± 0.50°	3.00° ± 0.50°	1.50° ± 0.25°	0.00" ± 0.13"
(W) D100-200—Except 200HD	69-70	1.50° ± 0.50°	1.50° ± 0.50°	3.00° ± 0.25°	0.06" ± 0.06"
FORD					
Excursion	00-05	3.50° ± 2.00°	3.50° ± 2.00°	0.25° ± 1.00°	0.02" ± 0.13"
F-250, F-350	05-14	3.50° ± 1.50°	3.50° ± 1.50°	0.15° ± 0.45°	0.188" ± 0.063"
F-250, F-350 Super Duty	99-04	3.50° ± 2.00°	3.50° ± 2.00°	0.25° ± 1.00°	0.02" ± 0.13"
F150	04-08	4.30° ± 1.00°	4.30° ± 1.00°	-0.20° ± 0.75°	0.15" ± 0.25"
F-150	97-03	4.60° ± 1.00°	5.30° ± 1.00°	-0.10° ± 0.70°	0.10" ± 0.13"
Expedition	97-02	5.00° ± 1.00°	5.00° ± 1.00°	-0.30° ± 0.75°	0.14" ± 0.20"
F-150, Bronco Full Size	89-96	Min. = 2.00° Max. = 6.00°	Min. = 2.00° Max. = 6.00°	0.25° ± 0.50°	0.03" ± 0.13"
F-150	80-88	Min. = 2.50° Max. = 7.50°	Min. = 2.50° Max. = 7.50°		0.03" ± 0.13"
F-100, F-150	73-79	3.50° ± 0.75°	3.50° ± 0.75°	1.50° ± 0.50°	0.09" ± 0.06"
Bronco	78-79	3.50° ± 0.75°	3.50° ± 0.75°	1.50° ± 0.50°	0.09" ± 0.06"
Ranger	93-97	Min. = 2.00° Max. = 6.00°	Min. = 2.00° Max. = 6.00°	0.25° ± 0.50°	0.03" ± 0.13"
Ranger—with Dana 35 & 28	89-92	Min. = 2.50° Max. = 6.00°	Min. = 2.50° Max. = 6.00°	0.25° ± 1.00°	0.00" ± 0.13"
Ranger	83-88	Min. = 2.50° Max. = 6.30°	Min. = 2.50° Max. = 6.30°	Min. = -0.05°	0.03" ± 0.13"
JEEP					
Liberty	02-07	3.875° ± 0.50°	3.875° ± 0.50°	-0.375° ± 0.38	0.12" ± 0.06"
Commander XK	05-07	4.00° ± 0.45°	4.00° ± 0.45°	1.25° ± 0.50°	0.25" ± 0.20"
Grand Cherokee WK	05-07	4.00° ± 0.45°	4.00° ± 0.45°	1.25° ± 0.50°	0.25" ± 0.20"
Grand Cherokee WJ	99-04	6.75° ± 0.75°	6.75° ± 0.75°	-0.37° ± 0.38	0.10" ± 0.03"
Grand Cherokee ZJ	93-98	5.00° ± 0.50°	5.00° ± 0.50°	-0.50° ± 0.63°	0.12" ± 0.10"
Cherokee XJ	95-01	5.00° +1.50° -1.75°	5.00° +1.50° -1.75°	-0.25° +0.75° -0.50°	0.188" ± 0.063"
Cherokee XJ	84-94	7.50° ± 0.50°	7.50° ± 0.50°	0.00° +0.50° -0.75°	0.188" ± 0.063"
Comanche MJ	86-91	7.50° ± 0.50°	7.50° ± 0.50°	0.00° +0.50° -0.75°	0.00" ± 0.06"
Wrangler JK	07-14	4.20° ± 0.50°	4.20° ± 0.50°	-0.25° +0.37°	0.12" ± 0.060"
Wrangler TJ	97-06	5.00° ± 1.00°	5.00° ± 1.00°	0.25° ± 0.63°	0.188" ± 0.063"
Wrangler YJ	87-95	8.00° ± 0.25°	8.00° ± 0.25°	0.00° ± 0.50°	0.188" ± 0.063"
CJ7, CJ8	81-86	6.00° ± 1.00°	6.00° ± 1.00°	0.00° ± 0.50°	0.07" ± 0.02"
CJ5, CJ6, CJ7, CJ8	72-80	3.00° ± 1.00°	3.00° ± 1.00°	1.50° ± 0.50°	0.07" ± 0.02"
Grand Wagoneer, Grand Cherokee SJ	74-90	4.00° ± 0.50°	4.00° ± 0.50°	0.00° ± 0.50°	0.06" ± 0.16"
SUZUKI					
Samurai	85-95	3.50° ± 1.00°	3.50° ± 1.00°	1.00° ± 0.75°	0.15" ± 0.10"
TOYOTA					
T100 Truck	93-98	0.92° ± 0.75°	0.92° ± 0.75°	0.58° ± 0.75°	0.07" ± 0.10"
Truck	86-95	1.90° ± 0.50°	1.90° ± 0.50°	0.73° ± 0.50°	0.09" ± 0.10"
4Runner	86-89	1.90° ± 0.50°	1.90° ± 0.50°	0.73° ± 0.50°	0.09" ± 0.10"

Note:
 Specifications listed are front only.
 Toyota Tundra, FJ Cruiser, and Tacoma use OE alignment specifications.

SPECIFICATIONS

INSTALLATION TIME & TIRE SIZE GUIDE

CHEVROLET/
GMC

DODGE

FORD

JEEP

SUZUKI

TOYOTA

POSI-LOK

SHOCKS/
STEERING
STABILIZERS

APPAREL/
PROMOTIONAL

PRODUCT
SPECS

VEHICLE
SPECS

Application	Amount of Lift	Installation Time	Tire Size	Wheel Size	Knuckle	Back-spacing	Foot Notes
CHEVROLET/GMC							
2007-2014 1/2 Ton Silverado/Sierra 4WD							
	4"	8-10	33" x 12.50"	17x9		5"	C, D
	4"	8-10	33" x 12.50"	20x9		5.75"	C, D
	6"	8-10	35" x 12.50"	17x9		5"	C, D
	6"	8-10	35" x 12.50"	20x9		5.75"	C, D
1999-2006 1/2 Ton Silverado/Sierra 4WD							
	4.5"	8-10	33" x 12.50"	16x8		4.5"	C, D
	4.5"	8-10	33" x 12.50"	17/18x9		5"	C, D
	4.5"	8-10	33" x 12.50"	20x9		5.75"	C, D
	6.5"	8-10	35" x 12.50"	16x8		4.5"	C, D
	6.5"	8-10	35" x 12.50"	17/18x9		5"	C, D
	6.5"	8-10	35" x 12.50"	20x9		5.75"	C, D
2011-2014 K2500 HD 4WD							
	6.5"	8-10	37" x 12.50"	17/18x9		4.625"	C, D
	6.5"	8-10	37" x 12.50"	20x9		6"	C, D
2001-2010 3/4 Ton K2500 HD 2WD & 4WD							
Old Body Style	4.5"	8-10	35" x 12.50"	16x8		4.5"	C, D
Old Body Style	4.5"	8-10	35" x 12.50"	17/18x9	NT	5"	C, D
Old Body Style	4.5"	8-10	35" x 12.50"	17/18x9	STD	5.5"	C, D
Old Body Style	4.5"	8-10	35" x 12.50"	20x9		5.75"	C, D
Old Body Style	7"	8-10	35" x 12.50"	16x8		4.5"	C, D
Old Body Style	7"	8-10	37" x 12.50"	17/18x9	NT	5"	C, D
Old Body Style	7"	8-10	37" x 12.50"	17/18x9	STD	5.5"	C, D
Old Body Style	7"	8-10	37" x 12.50"	20x9		5.75"	C, D
New Body Style	4.5"	8-10	33" x 12.50"	17/18x9	NT	5"	C, D
New Body Style	4.5"	8-10	33" x 12.50"	17/18x9	STD	5.5"	C, D
New Body Style	4.5"	8-10	33" x 12.50"	20x9		5.75"	C, D
New Body Style	7"	8-10	35" x 12.50"	17/18x9	NT	5"	C, D
New Body Style	7"	8-10	35" x 12.50"	17/18x9	STD	5.5"	C, D
New Body Style	7"	8-10	35" x 12.50"	20x9		5.75"	C, D
2001-2006 K2500 Non-HD, K2500 Suburban, Avalanche 4WD							
	6"	8-10	33" x 12.50"	16x8		4.5"	C, D
	6"	8-10	35" x 12.50"	17x9		5"	C, D
	6"	8-10	35" x 12.50"	20x9		5.75"	C, D
2007-2014 Tahoe, Yukon, Suburban, Avalanche, K1500 4WD							
	4"	8-10	33" x 12.50"	17x9		5"	C, D
	4"	8-10	33" x 12.50"	20x9		5.75"	C, D
	6"	8-10	34" x 12.50"	17x9		5"	C, D
	6"	8-10	35" x 12.50"	20x9		5.75"	C, D
1999-2006 Tahoe, Yukon, Suburban, Avalanche, K1500 4WD							
	4.5"	6-8	32 x 11.50"	16x8		4.5"	C, D
	4.5"	6-8	33 x 12.50"	17x9		5"	C, D
	4.5"	6-8	33 x 12.50"	20x9		5.75"	C, D
	6"	8-10	33" x 12.50"	16x8		4.5"	C, D
	6"	8-10	33" x 12.50"	17x9		5"	C, D
	6"	8-10	35" x 12.50"	20x9		5.75"	C, D
1988-1998 1/2 Ton K1500, K2500 4WD							
1992-1998 Tahoe, Yukon, Suburban 1500 4WD							
	6"	6-8	35 x 12.50"	15x8		3-5/8"	B, C
	6"	6-8	35 x 12.50"	16x8		4.5"	B, C
	6"	6-8	35 x 12.50"	17x9		4.5	B, C
Rear Block & Add-A-Leaf	6"	6-8	35" x 12.50"	20x9		5.25"	B, C
2002-2009 Trailblazer							
Rear Coil Mount	2"	3-4	30" x 9.50"	17x7		OEM	D
1995-2004 S-series ZR2							
Rear Axle Flip	5"	10-12	32" x 12.50"	15x8		5"	B
1995-2005 S-10 4WD							
Rear Axle Flip	5"	10-12	31" x 10.50"	15x8		5-6"	B
1988-1994 S-10 4WD							
Rear Axle Flip	5"	10-12	32" x 11.50"	15x8		5-6"	B

See Notes ▶

Note:

1. Due to the amount of lift achieved by BDS Systems you may encounter tire to fender/flare interference.
2. NT = Narrow Track Knuckle, STD = Standard Knuckle

Continued ▶

SPECIFICATIONS

INSTALLATION TIME & TIRE SIZE GUIDE

Application	Amount of Lift	Installation Time	Tire Size	Wheel Size	Back-spacing	Foot Notes
CHEVROLET/GMC						
1973-1991 Blazer, Jimmy, Suburban 4WD						
Without Rear Springs	2.5"	4	33" x 12.50"	15x8	3.5"	
With Rear Springs & Steering Arm	2.5"	5-6	33" x 12.50"	15x8	3.5"	
Without Rear Springs	4"	4	33" x 12.50"	15x8	3.5"	
With Rear Springs & Steering Arm	4"	5-6	33" x 12.50"	15x8	3.5"	
Without Rear Springs	6"	4	36" x 15"	15x10	3.5"	
With Rear Springs & Steering Arm	6"	5-6	36" x 15"	15x10	3.5"	
With Rear Springs	8"	7-8	38" x 15"	15x10/15x12	3.5"	
1969-1972 1/2, 3/4 Ton PU, Blazer, Jimmy 4WD						
Without Rear Springs	4"	4	33" x 12.50"	15x8	3.5"	
With Rear Springs	4"	5-6	33" x 12.50"	15x8	3.5"	
DODGE						
2013-2014 RAM 3500 Truck 4WD						
	2"	4	35 x 12.50"	17x9	5"	C
	4"	5	37 x 12.50"	17x9	5.625"	C
	6"	5-6	37 x 12.50"	17x9	4.5"-5.625"	
2014 RAM 2500 Truck 4WD						
	2"	4	35 x 12.50"	17x9	5"	C
	4"	5	37 x 12.50"	17x9	5.625"	C
	6"	5-6	37 x 12.50"	17x9	4.5"-5.625"	
2009-2013 1/2 Ton Truck 4WD						
	4"	8	35 x 12.50"	17x9	4.5"	C
	4"	8	35 x 12.50"	18x9	5"	C
	4"	8	35 x 12.50"	20x9	5"	C
	6"	8-10	37" x12.50"	17x8	4.5"	C
	6"	8-10	37" x12.50"	18x9	5"	C
	6"	8-10	37" x12.50"	20x9	5"	C
2006-2008 1/2 Ton Truck 4WD						
Front Leveling Kit	2"	3	33" x 12.50"	17x9	4.5"	
Rear Block Kit	4"	8-10	35 x 12.50"	17x9	4.5"	C
	4"	8-10	35 x 12.50"	18x9	5"	C
	4"	8-10	35 x 12.50"	20x9	5"	C
	6"	8-10	37 x 12.50"	17x9	4.5"	C
	6"	8-10	37 x 12.50"	18x9	5"	C
	6"	8-10	37 x 12.50"	20x9	5"	C
2002-2005 1/2 Ton Truck 4WD						
	4"	8	35" x 12.50	17x9	4.5"	C
	4"	8	35" x 12.50	20x9	5"	C
With Rear Block	6"	8-10	36" x 12.50"	17x9	4.5"	C
With Rear Spring	6"	8-10	36" x 12.50"	20x9	5"	C
1994-2001 1/2 Ton Truck 4WD						
Rear Block & Add-A-Leaf	3"	3-4	33" x 12.50"	16x8	3.5"-4"	
Rear Shackle Inversion	5"	6-8	35" x 12.50"	16x8	3.5"-4"	B
Rear Springs	5"	8-10	35" x 12.50"	16x8	3.5"-4"	
2003-2013 3/4 Ton Truck 4WD						
Front Coil Spacer	2"	4	33" x 12.50"	17x9	5"	
Front Coil Spacer & Rear Block	3"	5	33" x 12.50"	17x9	5"	
Front Coil & Rear Block	6"	6-8	36" x 12.50"	17x9	4.5"	
Front Coil & Rear Block	8"	6-8	39" x 14.00"	17x9	4.5"	
1994-2002 3/4 Ton V8/V10 Gas Truck 4WD						
Front Spacers	2"	4-6	33" x 12.50"	16x8	4"	
Rear Block & Add-A-Leaf	5"	6-8	35" x 12.50"	16x8	4"	
Rear Springs	5"	8-10	35" x 12.50"	16x8	4"	
1994-2002 3/4 Ton Diesel Truck 4WD						
Front Spacers	2"	4	33" x 12.50"	16x8, 16x10	4"	
Front Spacers & Rear Springs	2"	6-8	33" x 12.50"	16x8, 16x10	4"	
Rear Block & Add-A-Leaf	4.5"	8-10	35" x 12.50"	16x8, 16x10	4"	
Rear Springs	4.5"	8-10	35" x 12.50"	16x8, 16x10	4"	
1969-1993 1/2, 3/4 Ton Truck 4WD						
Without Rear Springs	5"	5-6	35" x 12.50"	15x8/15x12	3.5"-4"	
With Rear Springs	5"	5-6	35" x 12.50"	15x8/15x12	3.5"-4"	
FORD						
1973-1979 F-100, F-150 4WD						
Rear Block Kit	4"	6	33" x 12.50"	15x8	3.5"	A
Rear Block and Add-A-Leaf	6"	6	35" x 12.50"	15x8/15x10	3.5"	A
1978-1979 Bronco 4WD						
Rear Block	4"	6	33" x 12.50"	15x8	3.5"	A
Rear Block and Add-A-Leaf	6"	6	35" x 12.50"	15x8/15x10	3.5"	A
1983-97 Ranger 4WD						
Rear Block & Add-A-Leaf	4"	6	31" x 10.50"	15x7/15x8	3.5"	A
Rear Block & Add-A-Leaf	6"	6	33" x 10.50"	15x8	3.5"	A
1982-91 Bronco II 4WD						
Rear Block & Add-A-Leaf	4"	6	31" x 10.50"	15x8	3.5"	A
Rear Block & Add-A-Leaf	6"	6	33" x 10.50"	15x8	3.5"	A

SPECIFICATIONS

INSTALLATION TIME & TIRE SIZE GUIDE

CHEVROLET/
GMC

DODGE

FORD

JEEP

SUZUKI

TOYOTA

POSI-LOK

SHOCKS/
STEERING
STABILIZERS

APPAREL/
PROMOTIONAL

PRODUCT
SPECS

VEHICLE
SPECS

Application	Amount of Lift	Installation Time	Tire Size	Wheel Size	Back-spacing	Foot Notes
FORD						
2009-2014 F150 4WD/2WD						
Upper Strut Mount	2.5"	2	35" x 12.50"	17x9	5.5-6.5"	
Front Strut Spacer	4"	8-10	35" x 12.50"	18x9	5"	
Front Strut Spacer	4"	8-10	35" x 12.50"	20x9	5.5"	
Front Strut Replacement	6"	10	37" x 12.50"	18x9	5"	
Front Strut Replacement	6"	10	37" x 12.50"	20x9	5.5"	
2004-2008 F150 4WD						
Upper Strut Mount	2"	3	33" x 12.50"	17x9	4-5/8"	
Strut Spacer	4"	8-10	35" x 12.50"	20x9	5.5"	C
Strut Replacement or Spacer	6"	8-10	35" x 12.50"	17x9	4-5/8"	D
Strut Replacement or Spacer	6"	8-10	36" x 13.50"	20x9	5.5"	D
Strut Replacement	8"	10-12	37" x 12.50"	17x9	4-5/8"	D
Strut Replacement	8"	10-12	37" x 13.50"	20x9	5.5"	D
1997-2003 F-150 4WD						
Rear Block & Add-A-Leaf	6"	8-10	35" x 12.50"	16x8	4.5"	C
1998-2002 Expedition 4WD						
Rear Coil & 4-Link	6"	8-10	35" x 12.50"	16x8	4.5"	C
1980-1996 F-100, F-150 4WD						
Front Coils	1-2"	2	30" x 9.50"	15x8	3.5"	A
Front Coils & Brackets	4"	7-8	33" x 12.50"	15x8	3.5"	A
Front Coils & Brackets	6"	7-8	35" x 12.50"	15x8/15x10	3.5"	A
1980-1996 Bronco Full Size						
Front Coils	1-2"	2	30" x 9.50"	15x8	3.5"	A
Front Coils & Brackets	4"	7-8	33" x 12.50"	15x8	3.5"	A
Front Coils & Brackets	6"	7-8	35" x 12.50"	15x8/15x10	3.5"	A
2005-2014 F-250, 350 Super Duty						
Spacer Kit	1"	2-3	32" x 12.50"	17x9	4.5"	
Spacer Kit	2"	3-4	33" x 12.50"	17x9	4.5"	
Rear Springs	4"	6-8	35" x 12.50"	17x9	4.5"	C
Rear Springs	6"	6-8	37" x 12.50"	17x9	4.5"	C
Rear Springs	8"	8-9	38" x 15.50"	17x9	4.5"	E
1999-2004 F-250, 350 Super Duty						
Shackle Hanger Kit	2.5"	4-5	33" x 12.50"	16x8/16x10	4"	
Front Springs	2.5"	4	33" x 12.50"	16x8/16x10	4"	
Rear Block & Add-A-Leaf	4"	6-8	35" x 12.50"	16x10	4"	
Rear Springs	6"	8-10	36" x 13.50"	16x10	4"	
Rear Springs	8"	8-10	38" x 12.50/14.50"	16x10/16x12	4"-4.5"	
2000-2003 Excursion 4WD Gas and Diesel						
Front Spring & Rear Block	4"	5-6	33" x 12.50"	16x8/16x10	4"	
Front & Rear Springs	4"	6-8	33" x 12.50"	16x8/16x10	4"	
Rear Block & Add-A-Leaf	6"	6-8	35" x 12.50"	16x10	4"-4.5"	
Rear Springs	6"	8-10	35" x 12.50"	16x10	4"-4.5"	
Rear Springs	8"	8-10	36" x 12.50/13.50"	16x10	4"-4.5"	
Rear Springs	10"	8-10	38" x 12.50/14.50"	16x10/16x12	4"-4.5"	
1980-1996 F-250 TTB Front Axle 4WD						
Rear Block & Add-A-Leaf	4"	7-8	35" x 12.50"	16x8	4"	A
1986-1997 F-350 w/ Monobeam Front Axle						
Rear Block & Add-A-Leaf	4"	7-8	35" x 12.50"	16x8	4"	
JEEP						
1953-1975 CJ5, CJ6, M38A1						
Front & Rear Leaf Springs	2.5"	4-5	31" x 10.50"	15x7	3.5"	
1974-1990 J10, J20 Large Wagoneer, Cherokee FS						
Without Rear Leaf Springs	4"	4-5	33" x 12.50"	15x8	3.5"	
With Rear Leaf Springs	4"	4-5	33" x 12.50"	15x8	3.5"	
1976-1986 CJ5, CJ7, Scrambler						
Front & Rear Leaf Springs	2.5"	5-6	32" x 11.50"	15x8	3.5"	
Front & Rear Leaf Springs	4"	5-6	33" x 12.50"	15x8	3.5"	
1987-1995 Wrangler YJ						
Front & Rear Leaf Springs	2"	6	31" x 10.50"	15x8	3.5"	
Front & Rear Leaf Springs	3.5"	6	33" x 12.50"	15x8	3.5"	
Front & Rear Leaf Springs	4.5"	8	33" x 12.50"	15x8	3.5"	
Front & Rear Leaf Springs	5"	8	33" x 12.50"	15x8	3.5"	
Front & Rear Leaf Springs	6"	8	35" x 12.50"	15x8	3.5"	

SPECIFICATIONS

INSTALLATION TIME & TIRE SIZE GUIDE

Application	Amount of Lift	Installation Time	Tire Size	Wheel Size	Back-spacing	Foot Notes
JEEP						
1984-2001 Cherokee XJ						
Front Spacer & Rear Block	1.75"-2"	4	30" x 9.50"	15x7	3.5"-4"	
Front Coil & Rear Add-A-Leaf	3"	4-5	31" x 10.50"	15x8	3.5"-4"	C
Front Coil & Rear Springs	3"	5-6	31" x 10.50"	15x8	3.5"-4"	C
Front Coil & Rear Springs	4.5"	8	32" x 11.50"	15x8	4.75"	
Front Coil & Rear Springs	6.5"	10	33" x 12.50"	15x8	4.5"	
Front Coil & Rear Springs	8.5"	10	35" x 12.50"	15x8	4.5"	C
1993-1998 Grand Cherokee ZJ						
Front & Rear Coil Spacers	1.75"-2"	4	30" x 9.50"	15x7	3.5"	
Front & Rear Coil Springs	3"	6	31" x 10.50"	15x8	3.5"	C
Front & Rear Coil Springs	4.5"	10	31" x 10.50"	15x8	4.5"	C
Front & Rear Coil Springs	6.5"	10	33" x 12.50"	15x8	4.5"	C
2007-2014 Wrangler JK						
Front & Rear Coil Spacers	2"	4	33" x 12.50"	16x8	4.5"	
Front & Rear Coils	3"	6	35" x 12.50"	16x8	4.5"	
Front & Rear Coils	4.5"	8	37" x 12.50"	16x8	4.5"	
Front & Rear Coils	5.5/6.5"	10-12	37" x 12.50"	16x8	4.5"	
1997-2006 Wrangler TJ						
Front & Rear Coil Spacers	1.75"	2	32" x 11.50"	15x8/16x8	3.5"	
Front & Rear Coils	2"	4	32" x 10.50"	15x8/16x8	3.5"	
Front & Rear Coils	3"	6-8	33" x 12.50"	15x8/16x8	3.5"	
Front & Rear Coils	4.5"	8	33" x 12.50"	15x8/16x8	3.5"	
Front & Rear Coils	6.5"	10	35" x 12.50"	15x8/16x8	3.5"	
1999-2004 Grand Cherokee WJ						
Front & Rear Coil Springs	2"	5	31" x 10.50"	15x8/16x8	4.5-6"	
Front & Rear Coil Springs	4"	6	31" x 10.50"	15x8/16x8	4.5-6"	
2002-2007 Liberty KJ						
Front & Rear Coil Springs	2"	5	30" x 9.50"	16x8	5-1/4"	
2005-2006 Grand Cherokee WK						
Front Strut Spacer	2"	5	30" x 10.50"	17x8	6"	
Front Strut Spacer	4"	8	32" x 11.50"	17x8	5.5"	C
TOYOTA						
2007-2014 Toyota Tundra						
Front Strut Mount	3"	3	33" x 12.50"	18x8	6.25"	
IFS System	4.5"	10	35" x 12.50"	18"	5.5"	
IFS System	4.5"	10	35" x 12.50"	20"	6.25"	
IFS System	7"	10	37" x 12.50"	18"	5.5"	
IFS System	7"	10	37" x 12.50"	20"	6.25"	
2000-2006 Toyota Tundra						
Front Strut Mount & Rear Block	2.5"	6	32" x 11.50"	16x8	5"	
2005-2013 Toyota Tacoma						
IFS System	6"	6-8	35" x 12.50"	18x9/20x9	4.5"	C
IFS System	4"	6-8	33" x 12.50"	18x9/20x9	4.5"	C
1995.5-2004 Toyota Tacoma						
Front Strut Mount & Rear Add-A-Leaf	2.5"	6	32" x 11.50"	16x8	5"	
2007-2010 FJ Cruiser						
Front Strut Mount - Rear Coil	3"	5	285/75 R16	16x8	Stock	
1986-1995 Toyota Truck 4WD						
Front Torsion Bars & Rear Block	4"	8	35" x 12.50"	15x8	3.5"	
1993-1998 Toyota T100 Truck 4WD						
Front Torsion Bars & Rear Block	4"	8	33" x 12.50"	15x8	3.5"	
SUZUKI						
1985-1995 Suzuki Samurai						
Front & Rear Leaf Springs	4"	4	31" x 10.50"	15x8	3.5"	
1988-1998 Suzuki Sidekick 2dr						
Front & Rear Coil Springs	2"	5	235-75R15	15x7	3.5"	

Note: Due to the amount of lift achieved by BDS Systems you may encounter tire to fender/flare interference.

THIS GUIDE IS TO BE USED STRICTLY AS A REFERENCE!

Footnotes

- May require new alignment eccentrics to align after kit installation.
- Exhaust modification is required.
- Minor trimming required.
- If equipped with factory 17" wheels, then must replace with aftermarket 17" wheels. Do not downsize from any OEM wheel size!
- Bumper spacer kit #123020 required to run 38" tires.

The times mentioned above are estimates. Actual installation time will vary. Add extra time for wheel alignment, exhaust modification and driveshaft modification. These times are based on installation performed by an ASE certified mechanic who is familiar with the particular kit, has access to all necessary tools and equipment, and is safely installing a kit on a relatively clean and rust free vehicle. Note: Due to these factors BDS is not responsible for any estimates of time and/or dollars relative to this guide or any other reference to installation of any BDS Product.

- Always follow the recommendations of the individual tire and wheel manufacturers. Tires are generally designated by series and actual physical dimensions may vary.
- Most suspension systems will settle after installation and clearance will be reduced. When selecting a tire size, be sure to leave extra clearance for this to occur.
- Installation of a larger diameter tire may reduce the life of original OE suspension, steering, or related components. These items are not the responsibility of BDS Co.
- Larger tire diameters can cause premature wear of the clutch and/or transmission.
- Larger diameter tires may require recalibration of the speedometer and/or the anti-lock braking system and will reduce engine RPM throughout the range of the engine.
- Backspacing is defined as the measurement from the hub mounting surface to the extreme back edge (toward center of vehicle) of the wheel, not the bead seat. Some wheel manufacturers do not follow this definition, so always check clearances before operating the vehicle.

Vehicle	Year	Bolt Pattern	OE Back-spacing*	Lug Nut Size
CHEVROLET / GMC				
S/T Series P/U's, SUV's	'83-'03	5 on 4 3/4	Varies	12mmx1.5R
K5 Blazer, Jimmy, Suburban K10/15	'73-'91	6 on 5 1/2	3 5/8	7/16R
Suburban K20, K30	'73-'91	8 on 6 1/2	4 1/4	9/16R Duplex
Tahoe, Yukon	'92-'14	6 on 5 1/2	5 1/2	14mmx1.5R
Suburban K1500	'92-'14	6 on 5 1/2	5 1/2	14mmx1.5R
Suburban K2500	'92-'10	8 on 6 1/2	5 1/2	14mmx1.5R
Truck K10	'73-'87	6 on 5 1/2	3 5/8	7/16R
Truck K20, K30	'73-'87	8 on 6 1/2	4 1/4	9/16R Duplex
Truck K1500	'88-'98	6 on 5 1/2	5 1/2	14mmx1.5R
Truck K2500, K3500	'88-'98	8 on 6 1/2	5 1/2	14mmx1.5R
Silverado / Sierra 1500 (Non-HD)	'99-'03	6 on 5 1/2	5 1/4	14mmx1.5R
Silverado / Sierra 1500 HD, 2500	'99-'10	8 on 6 1/2	5 1/4	14mmx1.5R
Truck 2500	'11-'14	8 on 180mm	6 1/4	14mmx1.5R
Yukon XL HD, Sub HD, Avalanche HD	'99-'06	8 on 6 1/2	5 1/4	14mmx1.5R
Tahoe, Yukon XL, Denali (Non-HD)	'00-'14	6 on 5 1/2	5 1/4	14mmx1.5R
Avalanche	'01-'14	6 on 5 1/2	5 1/4	14mmx1.5R
Hummer H2	'03-'09	8 on 6 1/2	5 1/2	14mmx1.5R
Geo Tracker		5 on 5 1/2	3 3/4	12mmx1.25R
DODGE				
Dakota	'87-'90	5 on 4 1/2	5	1/2R
Truck 1/2 ton, Ram-charger	'74-'84	5 on 4 1/2	4	1/2R
Truck 1/2 ton, Ram-charger w/ manual hubs	'80-'93	5 on 5 1/2	3 3/4	1/2R
Truck 3/4, 1 ton	'46-'93	8 on 6 1/2	4	1/2 Duplex
Ram Truck 1500	'94-'01	5 on 5 1/2	5 1/2	1/2R
Ram Truck 1500	'02-'03	5 on 5 1/2	5 1/2	9/16R
Ram Truck 2500, 3500	'94-'01	8 on 6 1/2	4	9/16R Duplex
FORD / MERCURY / LINCOLN				
Ranger, Bronco II	'83-'92	5 on 4 1/2	4	1/2R
Ranger, Bronco II	'93-'03	5 on 4 1/2	4 1/2	1/2R
Explorer, Navajo, Mountaineer, (91-94)	'91-'00	5 on 4 1/2	4 1/2	1/2R
Explorer, Mountaineer, Aviator	'01-'03	5 on 4 1/2	4 1/2	1/2R
Bronco	'66-'79	5 on 5 1/2	3 3/4	1/2R
Bronco	'80-'96	5 on 5 1/2	3 3/4	1/2R
F-100, F-150	'65-'79	5 on 5 1/2	3 3/4	1/2R
F-150	'80-'96	5 on 5 1/2	3 3/4	1/2R
F-150	'97-'03	5 on 135mm	4 1/4	

Vehicle	Year	Bolt Pattern	OE Back-spacing*	Lug Nut Size
F-150	'04-'14	6 on 135mm		14mmx2.0
Expedition, Navigator	'97-'02	5 on 135mm	4 1/4	
F-250, F-350	'48-'96	8 on 6 1/2	4 1/4	9/16 or 1/2
F-250, F-350 w/ Dana 60	'48-'96	8 on 6 1/2	4 1/4	9/16 Duplex
Superduty	late '98-'02	8 on 170mm	4 1/4	14mmx2.0
Superduty	'03-'14	8 on 170mm		14mmx1.50
Excursion	'00-'05	8 on 170mm	4 1/4	14mmx2.0
JEEP				
Grand Cherokee ZJ	'93-'98	5 on 4 1/2	5 1/4	1/2R
Grand Cherokee WJ	'99-'03	5 on 5	5 1/4	1/2R
Wrangler YJ	'87-'95	5 on 4 1/2	4 1/2	1/2R
Wrangler TJ	'97-'03	5 on 4 1/2	4 1/2	1/2R
Wrangler JK	'07-'14	5 on 5		14mmx1.50
Cherokee XJ, Comanche MJ	'84-'01	5 on 4 1/2	4	1/2R
Liberty KJ	'02-'03	5 on 4 1/2	4	1/2R
CJ 5, 6, 7, 8 Scrambler	'55-'86	5 on 5 1/2	3 1/2	1/2R
J10, Wagoneer, Cherokee Full Size	'74-'91	6 on 5 1/2	3 1/2	7/16R
J20 Truck	'74-'88	8 on 6 1/2	4	1/2R Duplex
NISSAN				
Truck	'78-'86	6 on 5 1/2	4 1/2	12mmx1.25R
Hardbody Truck	'87-'97	6 on 5 1/2	4 1/2	12mmx1.25R
Frontier Truck		6 on 5 1/2	4 1/2	12mmx1.25R
Pathfinder		6 on 5 1/2	4 1/2	12mmx1.25R
Xterra		6 on 5 1/2	4 1/2	12mmx1.25R
SUZUKI				
Samurai	'85-'95	5 on 5 1/2	3 1/2	12mmx1.25R
Sidekick	'88-'98	5 on 5 1/2	3 1/2	12mmx1.25R
TOYOTA				
Truck	'79-'95	6 on 5 1/2	varies	12mmx1.5R
4 Runner	'86-'96	6 on 5 1/2	varies	12mmx1.5R
Tacoma Standard Cab	'86-'96	6 on 5 1/2	4 1/2	12mmx1.5R
T-100	'93-'98	6 on 5 1/2	4 1/2	12mmx1.5R
Tundra	'00-'06	6 on 5 1/2	5	12mmx1.5R
Tundra	'07-'13	5 on 150mm		14mmx1.50
FJ40 Land Cruiser	'75-'84	6 on 5 1/2	3 1/2	12mmx1.5R
FJ60 Land Cruiser	'84-'92	6 on 5 1/2	3 1/2	12mmx1.5R
FJ80 Land Cruiser	'94-'97	6 on 5 1/2	4 1/2	12mmx1.5R

*NOTE: This chart lists Original Equipment wheel specifications ONLY. Refer to the footnotes on the suspension application pages for any wheel references which may differ from those in this chart.

BACK SPACING

Also called rear spacing. Distance from extreme back edge of rim, not bead seat, to the mounting pad. Lay a straight edge across back edge of rim and measure down to mounting pad.

WHEEL OFFSET

The distance from the wheels centerline to the plane at which the wheel meets the hub. Positive offset is toward the outside of the rim, negative offset is toward the inside. Zero offset is the center of the rim.



BDS SUSPENSION

491 W GARFIELD AVE COLDWATER, MI 49036

P 517-279-2135 F 517-278-2316

BDS-SUSPENSION.COM

sales@bds-suspension.com • tech@bds-suspension.com • marketing@bds-suspension.com